

Code	Description	Notes
001_0_10370	ENGINE COVER (340)	
001_1_10402	ENGINE COVER (340)	
001_2_10428	ENGINE PROTECTIONS (340)	
001_3_10453	ENGINE PROTECTIONS (340)	
001_4_23329	ENGINE PROTECTIONS (340)	
001_5_24839	ENGINE PROTECTIONS (340)	
001_6_63810	ENGINE PROTECTIONS (340)	
002_2_10522	ELECTRIC STARTER (340)	
002_3_10539	ELECTRIC STARTER (340)	
002_4_23307	ELECTRIC STARTER (340)	
002_5_25058	ELECTRIC STARTER (340 - 346)	Version: MC 340, MC 346
002_6_33590	ELECTRIC STARTER (340 - 346)	
002_7_63846	ELECTRIC STARTER (340 - 346)	Version: MC 346, MC 340
003_0_10557	SELF-VENTILATING CONE CLUTCH	
003_1_10576	SELF-VENTILATING CONE CLUTCH	
003_2_10596	SELF-VENTILATING CONE CLUTCH	
003_3_25078	CLUTCH	Version: MC 346, MC 340
003_4_27606	SELF-VENTILATING CONE CLUTCH	
003_5_33490	CLUTCH	
004_0_10617	GEARBOX	
004_1_10650	GEARBOX	
004_2_10685	GEARBOX	
004_3_10722	GEARBOX	
004_4_25109	GEARBOX	Version: MC 340
006_0_10884	GEARS (340)	
006_1_10921	GEARS (340)	
006_2_10958	GEARS (340)	
006_3_25213	GEARS (340 - 346)	Version: MC 340, MC 346
009_0_11080	DIFFERENTIAL (340)	
009_1_11107	DIFFERENTIAL (340)	
011_0_11257	STEERING COLUMN AND CONTROLS (340)	
011_1_11314	STEERING COLUMN AND CONTROLS (340)	
011_2_11372	STEERING COLUMN AND CONTROLS (340)	
011_3_11435	STEERING COLUMN AND CONTROLS (340)	

Two-wheel tractor 340

Code	Description	Notes
011_4_25304	STEERING COLUMN (340-346)	Version: MC 346, MC 340
011_5_32699	STEERING COLUMN (340-346)	
011_6_33168	STEERING COLUMN (340-346)	
011_7_63924	STEERING COLUMN (340-346)	
011A_0_25340	CONTROLS (340-346)	Version: MC 346, MC 340
011A_1_32745	CONTROLS (340-346)	
013_0_11706	HANDLEBAR (340)	
013_1_11755	HANDLEBAR (340)	
013_2_11805	HANDLEBAR (340)	
013_3_11857	HANDLEBAR (340)	
013_4_25436	HANDLEBAR (340-346)	Version: MC 340, MC 346
013_5_32888	HANDLEBAR (340-346)	
013_6_33211	HANDLEBAR (340-346)	
013_7_64065	HANDLEBAR (340-346)	
014_0_11909	BRAKES (340)	
014_1_11927	BRAKES (340)	
014_2_25485	BRAKES (340-346)	Version: MC 340, MC 346
015_0_11945	WHEELS	
015_1_11971	WHEELS	
015_2_11997	WHEELS	
015_3_64117	WHEELS	
016_0_12023	STICKERS	
016_1_12046	STICKERS	
016_2_25498	STICKERS	
016_3_32939	STICKERS	
017_0_25512	STICKERS	

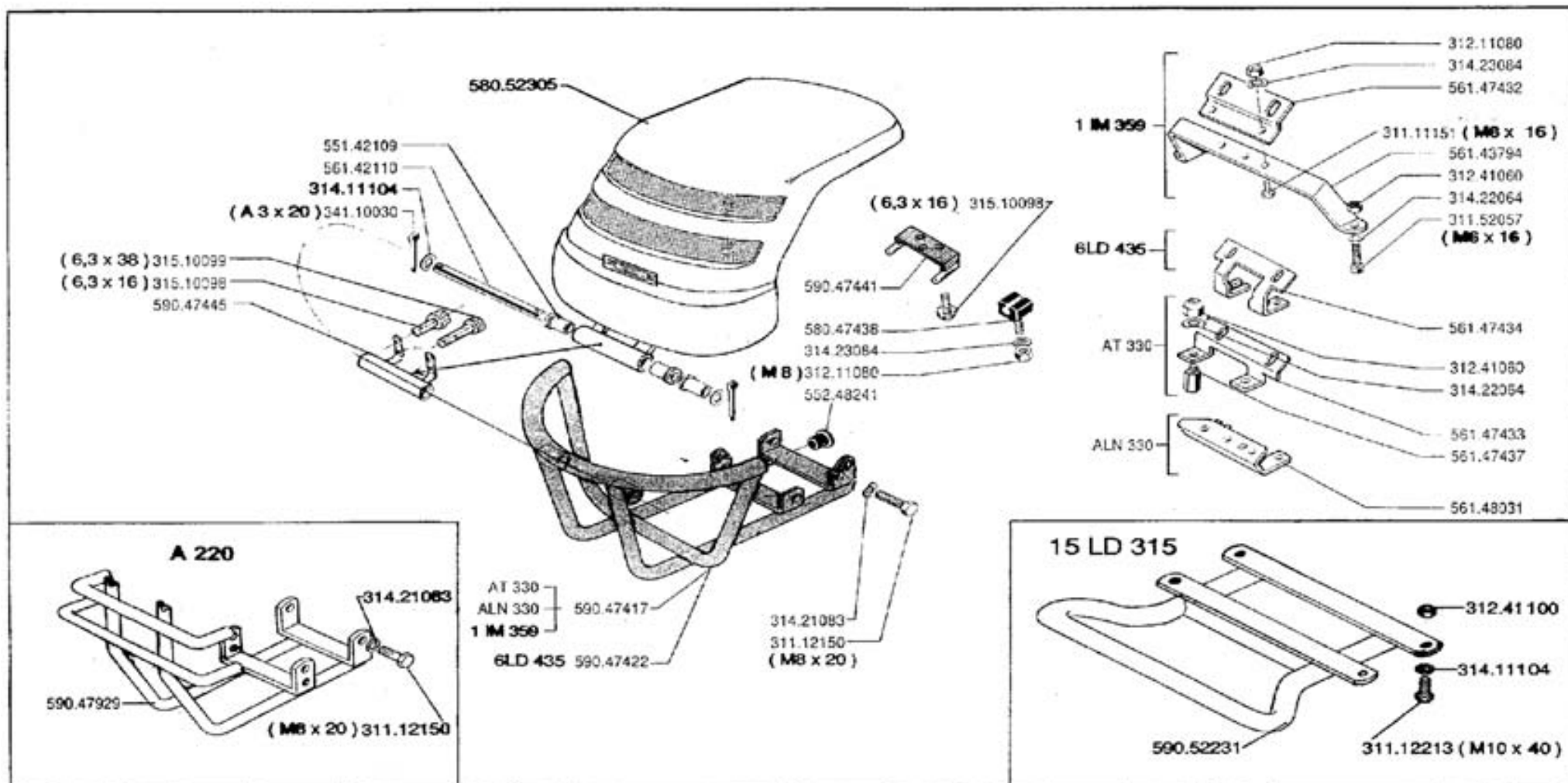

FERRARI

300 serie **95**

COFANO MOTORE

CAPO MOTOR
COFFRE MOTEUR

ENGINE COVER
MOTORHAUBE

DALLA MACCHINA
DE LA MACHINE
FROM THE MACHINE
AB DER MASCHINE

N.

01.00

01.06.1995

Pos.	Code	Q.ty	Description	Notes
31111151	31111151	0	SCREW TE M8X16 UNI 5739 8G	
31112150	31112150	0	SCREW TE M8X20 UNI 5739 8G	
31112213	31112213	0	SCREW TE M10X40 UNI 5739	
31152057	31152057	0	SCREW TCEI M6X16 UNI 5931	
31211080	31211080	0	NUT M8	
31241060	31241060	0	SELFLOCK NUT M6	
31241100	31241100	0	SELFLOCK NUT M10 6S	
31411104	31411104	0	WASHER 10,5x18	
31421083	31421083	0	WASHER	
31422064	31422064	0	SPRING WASHER 6,4	
31423084	31423084	0	SPRING WASHER 8,4	
31510098	31510098	0	RIBBED SCREW 6,3X16 UNI 6950	
31510099	31510099	0	RIBBED SCREW 6,3X38 UNI 6950	
34110030	34110030	0	SPLIT PIN	
55142109	55142109	0	BUSHING	
55248241	55248241	0	PLUG	
56142110	56142110	0	PIN	
56143794	56143794	0	CONNECTION	
56147432	56147432	0	HOLDER	
56147433	56147433	0	SUPPORT	
56147434	56147434	0	SUPPORT	
56147437	56147437	0	SPACER	
56148031	56148031	0	SUPPORT	
58047438	58047438	0	STOPPER	
58052305	58052305	0	BONNET	
59047417	59047417	0	COMPLETE BUMPERS	
59047422	59047422	0	COMPLETE BUMPERS	
59047441	59047441	0	STOP	
59047445	59047445	0	HOOD BEARING	
59047929	59047929	0	BUMPER	
59052231	59052231	0	PARAURTI COMPLETO	

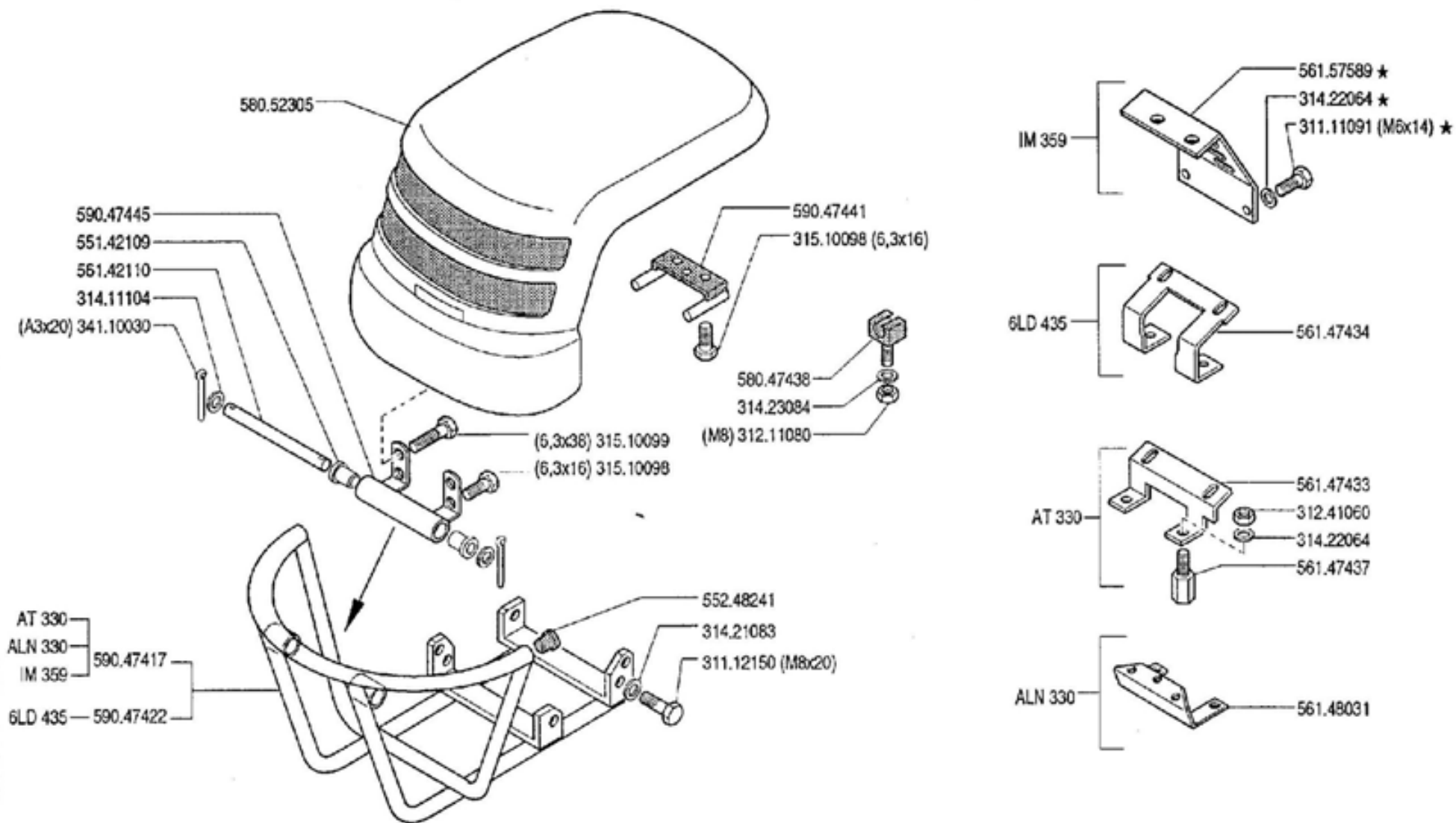

FERRARI

300 serie **95**

COFANO MOTORE (340)

CAPO MOTOR
COFFRE MOTEUR

ENGINE COVER
MOTORHAUBE

DALLA MACCHINA
DE LA MAQUINA
DE LA MACHINE
FROM THE MACHINE
AB DER MASCHINE

★ N.

01.01

11.1996

3898

Pos.	Code	Q.ty	Description	Notes
31111091	31111091	0	SCREW E M6X14 UNI 5739 8G	
31112150	31112150	0	SCREW TE M8X20 UNI 5739 8G	
31211080	31211080	0	NUT M8	
31241060	31241060	0	SELFLOCK NUT M6	
31411104	31411104	0	WASHER 10,5x18	
31421083	31421083	0	WASHER	
31422064	31422064	0	SPRING WASHER 6,4	
31423084	31423084	0	SPRING WASHER 8,4	
31510098	31510098	0	RIBBED SCREW 6,3X16 UNI 6950	
31510099	31510099	0	RIBBED SCREW 6,3X38 UNI 6950	
34110030	34110030	0	SPLIT PIN	
55142109	55142109	0	BUSHING	
55248241	55248241	0	PLUG	
56142110	56142110	0	PIN	
56147433	56147433	0	SUPPORT	
56147434	56147434	0	SUPPORT	
56147437	56147437	0	SPACER	
56148031	56148031	0	SUPPORT	
56157589	56157589	0	SUPPORT	
58047438	58047438	0	STOPPER	
58052305	58052305	0	BONNET	
59047417	59047417	0	COMPLETE BUMPERS	
59047422	59047422	0	COMPLETE BUMPERS	
59047441	59047441	0	STOP	
59047445	59047445	0	HOOD BEARING	

SERIAL
START
3898

END
6111

ENGINE COVER (340)

CODE REV
001_1_10402

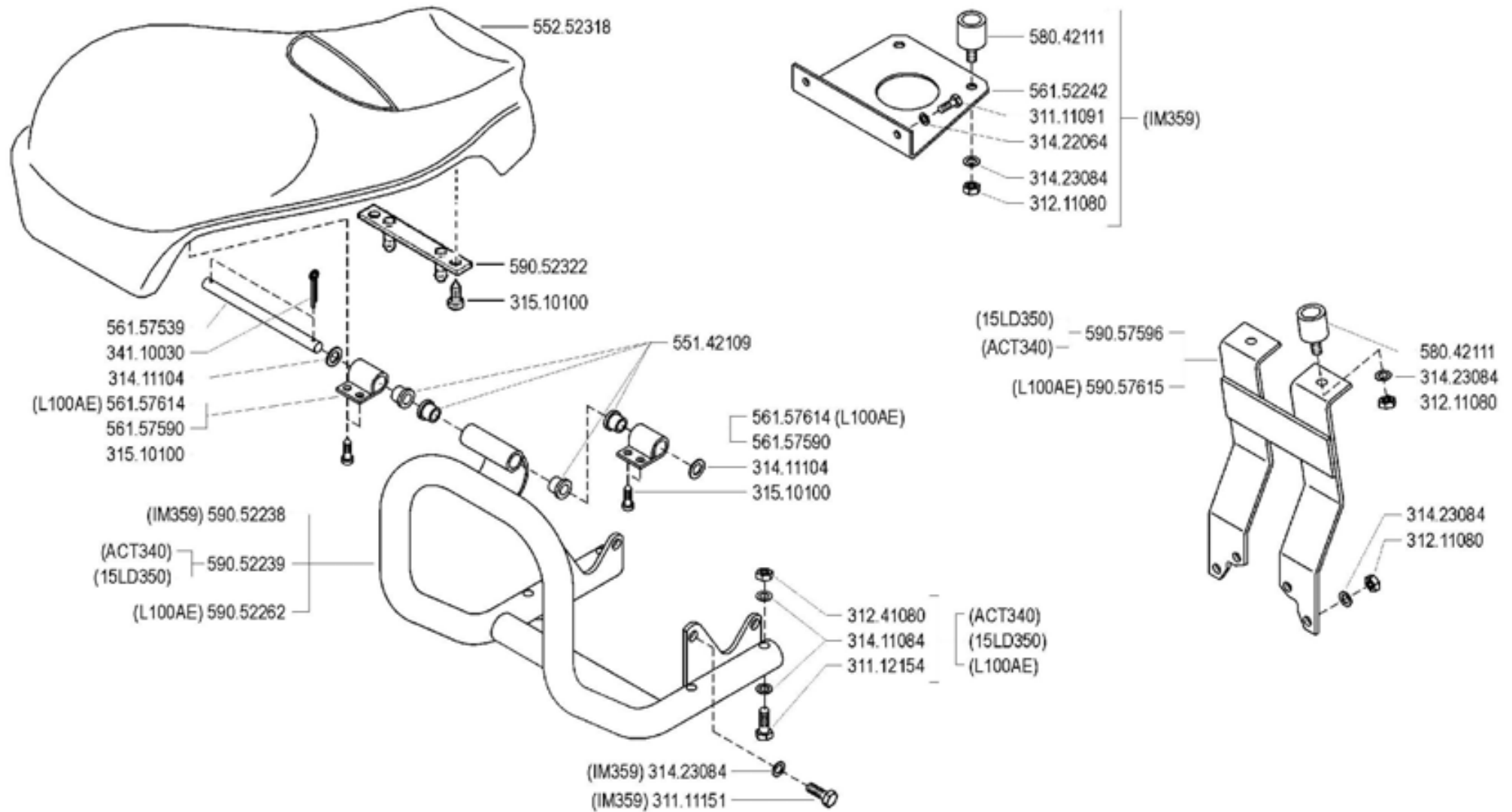

FERRARI

300 serie **95**

PROTEZIONI MOTORE (340) ★

ENGINE GUARDS
PROTECCIONES MOTOR

PROTECTIONS MOTEUR
MOTOR SCHUTZ

DALLA MACCHINA
DE LA MAQUINA
DE LA MACHINE
FROM THE MACHINE
AB DER MASCHINE

★ N.

6112

01 **02**

1/2000

ZF&M

Pos.	Code	Q.ty	Description	Notes
31111091	31111091	0	SCREW E M6X14 UNI 5739 8G	
31111151	31111151	0	SCREW TE M8X16 UNI 5739 8G	
31112154	31112154	0	SCREW TE M8X40 UNI 5739 8G	
31211080	31211080	0	NUT M8	
31241080	31241080	0	SELFLOCK NUT M8	
31411084	31411084	0	WASHER 8,4x17	
31411104	31411104	0	WASHER 10,5x18	
31422064	31422064	0	SPRING WASHER 6,4	
31423084	31423084	0	SPRING WASHER 8,4	
31510100	31510100	0	RIBBED SCREW 6,3X19 UNI 6950	
34110030	34110030	0	SPLIT PIN	
55142109	55142109	0	BUSHING	
55252318	55252318	0	ENGINE HOOD	
56152242	56152242	0	SUPPORT	
56157539	56157539	0	PIN	
56157590	56157590	0	HOOD HINGE	
56157614	56157614	0	HOOD HINGE	
58042111	58042111	0	STOPPER	
59052238	59052238	0	COMPLETE BUMPERS	
59052239	59052239	0	COMPLETE BUMPERS	
59052262	59052262	0	COMPLETE BUMPERS	
59052322	59052322	0	SUPPORT	
59057596	59057596	0	SUPPORT	
59057615	59057615	0	SUPPORT	

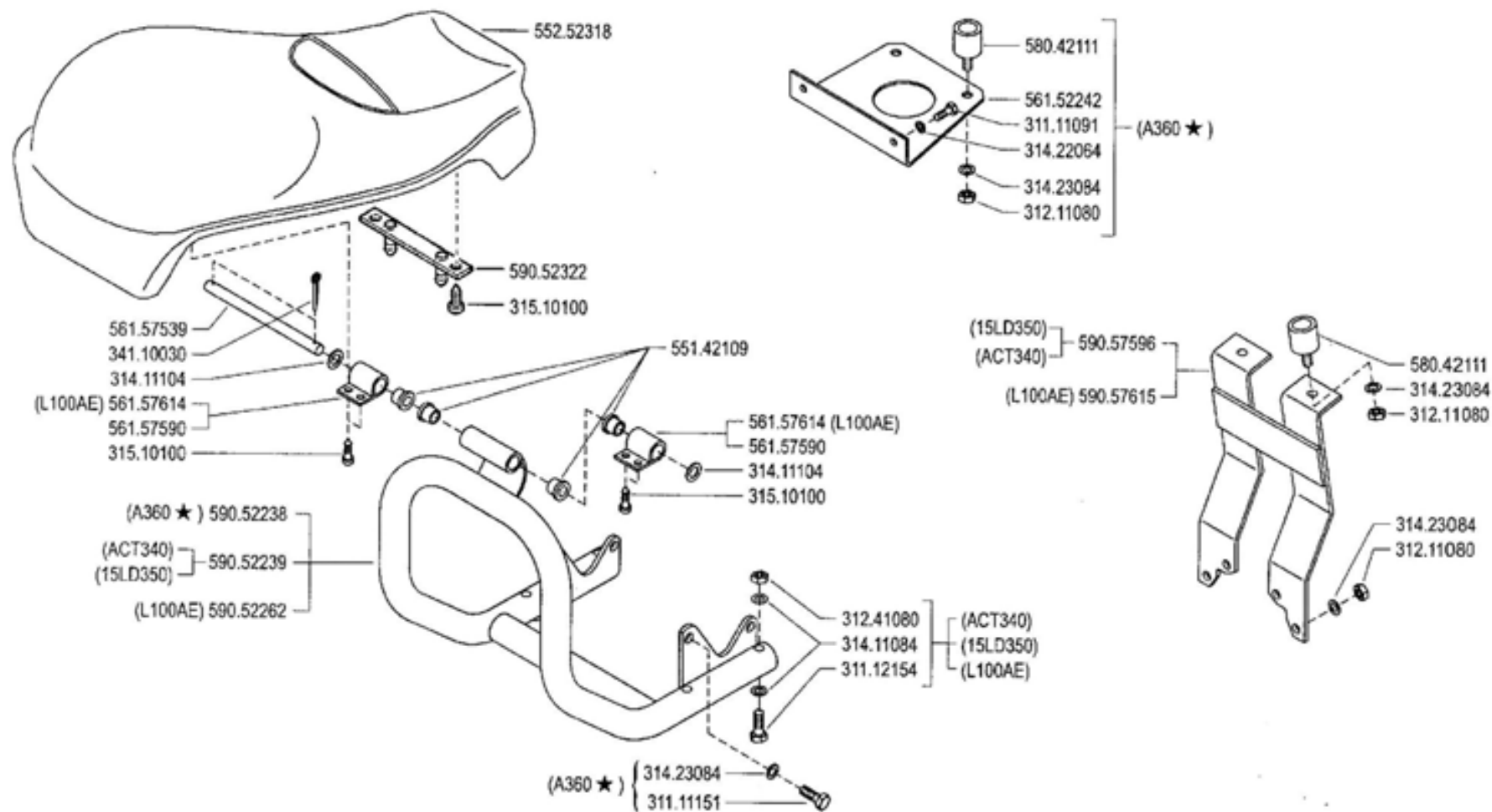

FERRARI

300 serie **95**

PROTEZIONI MOTORE (340)

ENGINE GUARDS
PROTECCIONES MOTOR

PROTECTIONS MOTEUR
MOTOR SCHUIZ

DALLA MACCHINA
DE LA MAQUINA
FROM THE MACHINE
AB DER MASCHINE

AGGIORNAMENTO
REVISION
MISE A JOUR
APLAZAMIENTO
ANPASSUNG

01

Rev.
3

3/2001

★N

FINALE

Pos.	Code	Q.ty	Description	Notes
31111091	31111091	0	SCREW E M6X14 UNI 5739 8G	
31111151	31111151	0	SCREW TE M8X16 UNI 5739 8G	
31112154	31112154	0	SCREW TE M8X40 UNI 5739 8G	
31211080	31211080	0	NUT M8	
31241080	31241080	0	SELFLOCK NUT M8	
31411084	31411084	0	WASHER 8,4x17	
31411104	31411104	0	WASHER 10,5x18	
31422064	31422064	0	SPRING WASHER 6,4	
31423084	31423084	0	SPRING WASHER 8,4	
31510100	31510100	0	RIBBED SCREW 6,3X19 UNI 6950	
34110030	34110030	0	SPLIT PIN	
55142109	55142109	0	BUSHING	
55252318	55252318	0	ENGINE HOOD	
56152242	56152242	0	SUPPORT	
56157539	56157539	0	PIN	
56157590	56157590	0	HOOD HINGE	
56157614	56157614	0	HOOD HINGE	
58042111	58042111	0	STOPPER	
59052238	59052238	0	COMPLETE BUMPERS	
59052239	59052239	0	COMPLETE BUMPERS	
59052262	59052262	0	COMPLETE BUMPERS	
59052322	59052322	0	SUPPORT	
59057596	59057596	0	SUPPORT	
59057615	59057615	0	SUPPORT	

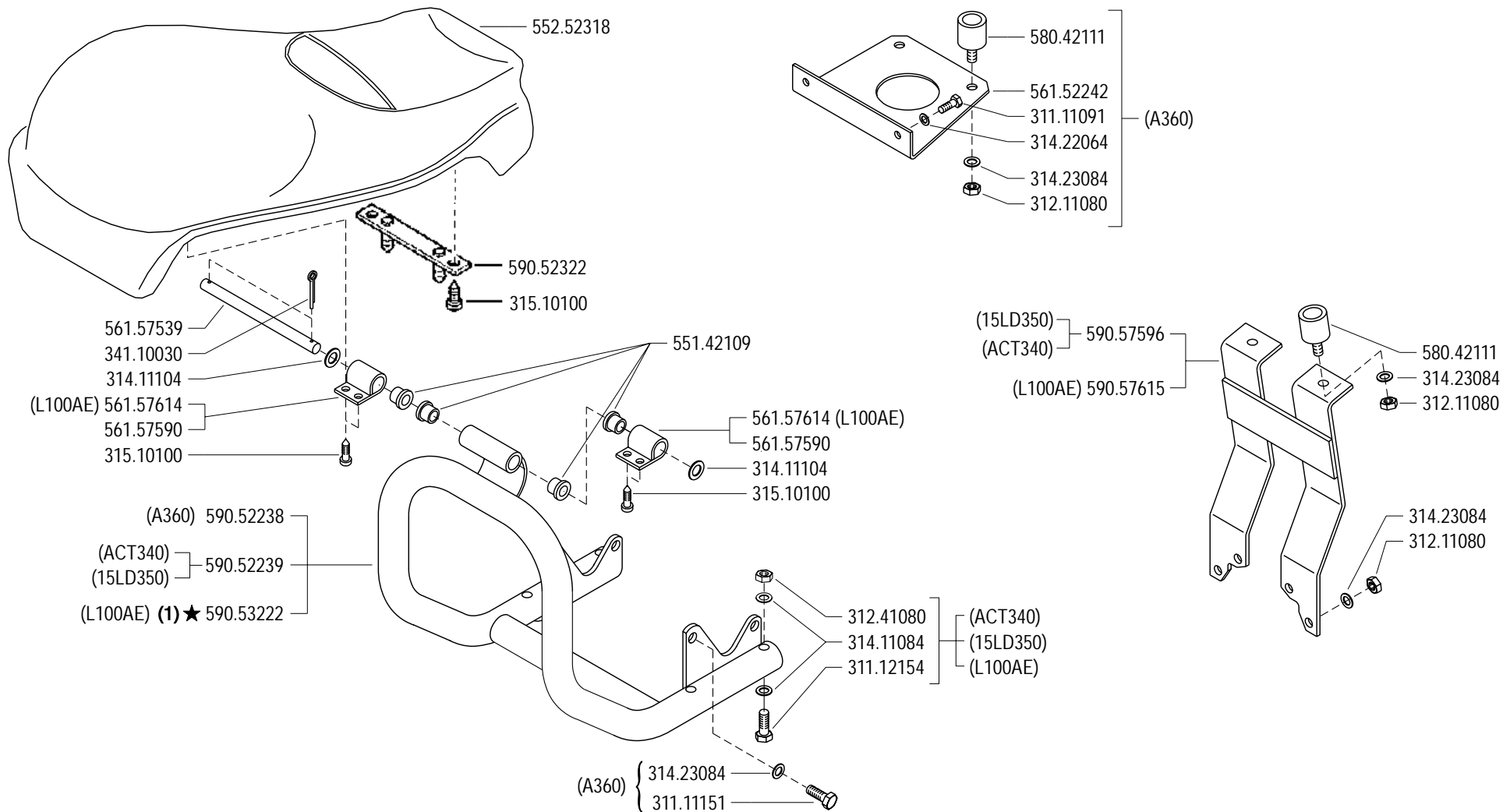

(1) sostituisce 590.52262

FERRARI

300 serie **95**

PROTEZIONI MOTORE (340)

ENGINE GUARDS
PROTECCIONES MOTOR

PROTECTIONS MOTEUR
MOTOR SCHUTZ

DALLA MACCHINA
DE LA MAQUINA
DE LA MACHINE
FROM THE MACHINE
AB DER MASCHINE

AGGIORNAMENTO

REVISION

MISE A JOUR

APLAZAMIENTO

ANPASSUNG

01

Rev.
4

3/2004

★N.

ZENNE

Pos.	Code	Q.ty	Description	Notes
31111091	31111091	0	SCREW E M6X14 UNI 5739 8G	
31111151	31111151	0	SCREW TE M8X16 UNI 5739 8G	
31112154	31112154	0	SCREW TE M8X40 UNI 5739 8G	
31211080	31211080	0	NUT M8	
31241080	31241080	0	SELFLOCK NUT M8	
31411084	31411084	0	WASHER 8,4x17	
31411104	31411104	0	WASHER 10,5x18	
31422064	31422064	0	SPRING WASHER 6,4	
31423084	31423084	0	SPRING WASHER 8,4	
31510100	31510100	0	RIBBED SCREW 6,3X19 UNI 6950	
34110030	34110030	0	SPLIT PIN	
55142109	55142109	0	BUSHING	
55252318	55252318	0	ENGINE HOOD	
56152242	56152242	0	SUPPORT	
56157539	56157539	0	PIN	
56157590	56157590	0	HOOD HINGE	
56157614	56157614	0	HOOD HINGE	
58042111	58042111	0	STOPPER	
59052238	59052238	0	COMPLETE BUMPERS	
59052239	59052239	0	COMPLETE BUMPERS	
59052262	59052262	1	COMPLETE BUMPERS	
59052322	59052322	0	SUPPORT	
59053222	59053222	1	COMPLETE BUMPERS	
59057596	59057596	0	SUPPORT	
59057615	59057615	0	SUPPORT	

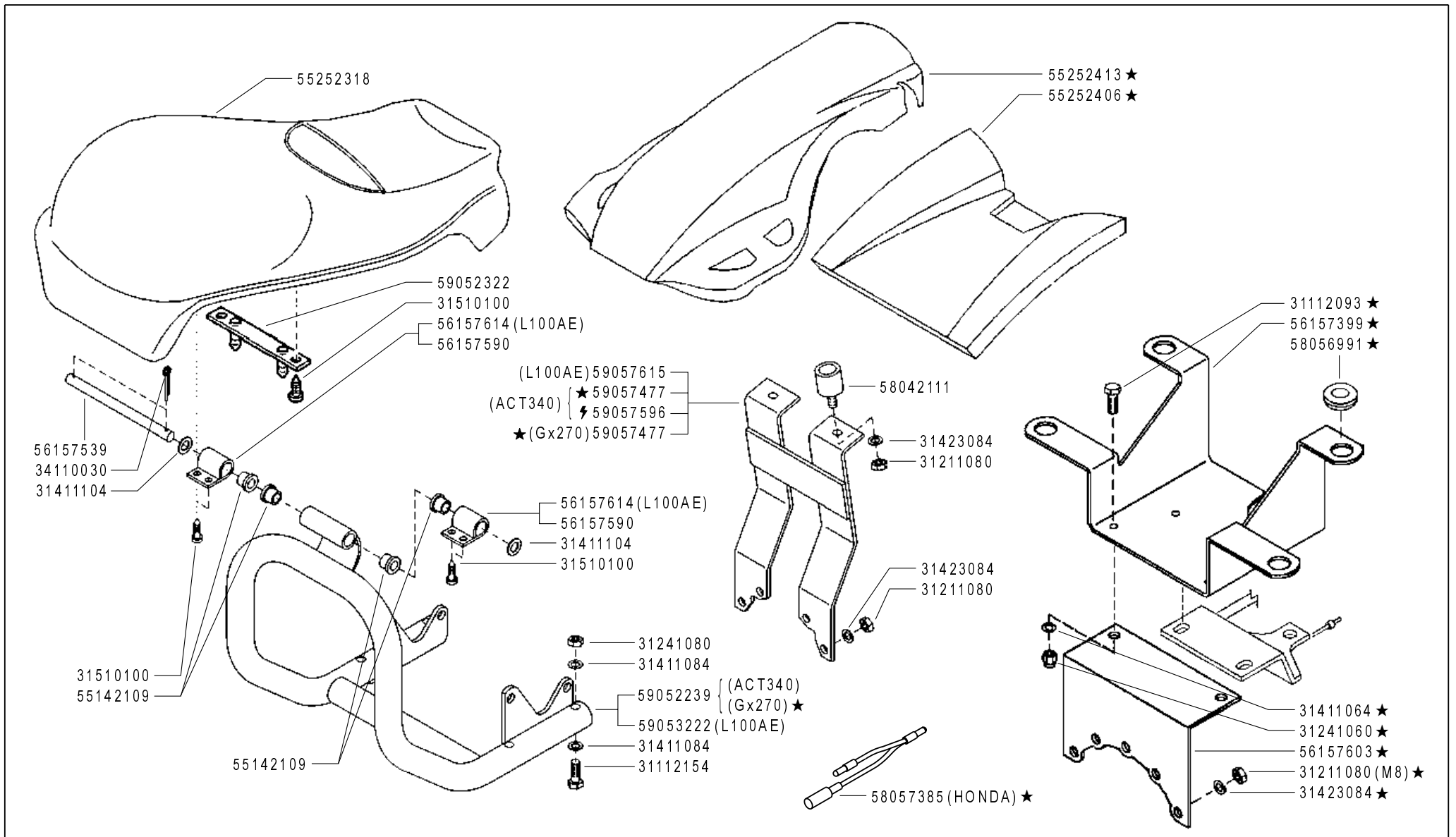

FERRARI

300 serie **95**

PROTEZIONI MOTORE (340)

ENGINE PROTECTIONS
PROTECCIONES MOTOR

PROTECTIONS MOTEUR
MOTORSCHUTZ

DALLA MACCHINA
DE LA MAQUINA
DE LA MACHINE
FROM THE MACHINE
AB DER MASCHINE

★ **N.**

749391

01

Rev.
5

02/2006

ZENNE

Pos.	Code	Q.ty	Description	Notes
31112093	31112093	1	SCREW TE M6X20 UNI 5739 8G	
31112154	31112154	1	SCREW TE M8X40 UNI 5739 8G	
31211080	31211080	1	NUT M8	
31241060	31241060	1	SELFLOCK NUT M6	
31241080	31241080	1	SELFLOCK NUT M8	
31411064	31411064	1	WASHER 6,4x12,5	
31411084	31411084	1	WASHER 8,4x17	
31411104	31411104	1	WASHER 10,5x18	
31423084	31423084	1	SPRING WASHER 8,4	
31510100	31510100	1	RIBBED SCREW 6,3X19 UNI 6950	
34110030	34110030	1	SPLIT PIN	
55142109	55142109	1	BUSHING	
55252318	55252318	1	ENGINE HOOD	
55252406	55252406	1	GUARD	
55252413	55252413	1	GUARD	
56157399	56157399	1	HOLDER	
56157539	56157539	1	PIN	
56157590	56157590	1	HOOD HINGE	
56157603	56157603	1	HOLDER	
56157614	56157614	1	HOOD HINGE	
58042111	58042111	1	STOPPER	
58056991	58056991	1	CABLE GLAND	
58057385	58057385	1	LINE	
59052239	59052239	1	COMPLETE BUMPERS	
59052322	59052322	1	SUPPORT	
59053222	59053222	1	COMPLETE BUMPERS	
59057477	59057477	1	SUPPORT	
59057596	59057596	1	SUPPORT	
59057615	59057615	1	SUPPORT	

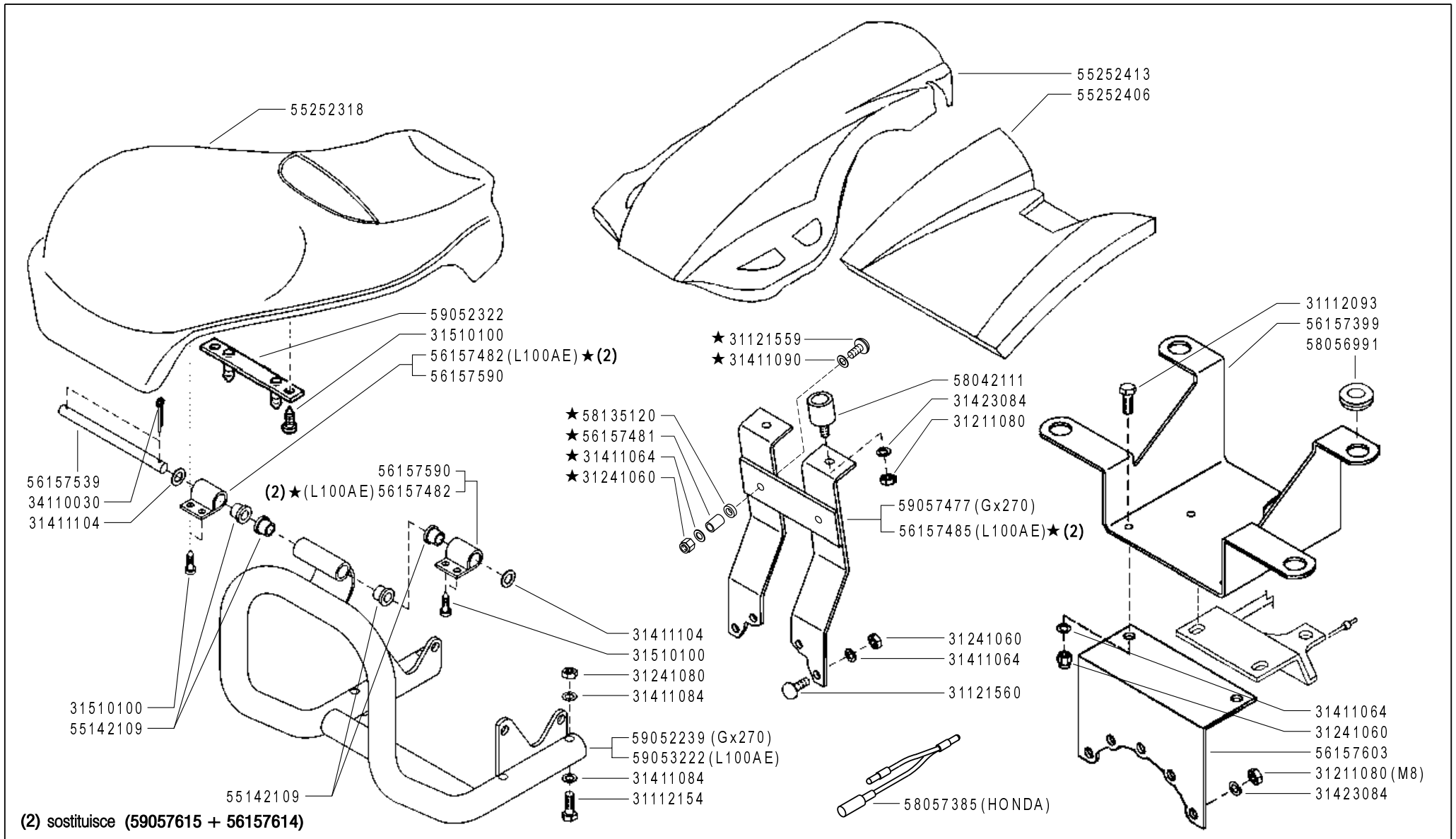

FERRARI

300 serie **95**

PROTEZIONI MOTORE (340)

ENGINE PROTECTIONS
PROTECCIONES MOTOR

PROTECTIONS MOTEUR
MOTORSCHUTZ

DALLA MACCHINA
DE LA MAQUINA
DE LA MACHINE
FROM THE MACHINE
AB DER MASCHINE

★ N.

(2) 828819

01

Rev.
6

01/2009

ZENNE

Pos.	Code	Q.ty	Description	Notes
31112093	31112093	1	SCREW TE M6X20 UNI 5739 8G	
31112154	31112154	1	SCREW TE M8X40 UNI 5739 8G	
31121559	31121559	1	SCREW TTQ M6X25 UNI 5731	
31211080	31211080	1	NUT M8	
31241060	31241060	1	SELFLOCK NUT M6	
31241080	31241080	1	SELFLOCK NUT M8	
31411064	31411064	1	WASHER 6,4x12,5	
31411084	31411084	1	WASHER 8,4x17	
31411090	31411090	1	WASHER 9x24	
31411104	31411104	1	WASHER 10,5x18	
31423084	31423084	1	SPRING WASHER 8,4	
31510100	31510100	1	RIBBED SCREW 6,3X19 UNI 6950	
34110030	34110030	1	SPLIT PIN	
55142109	55142109	1	BUSHING	
55252318	55252318	1	ENGINE HOOD	
55252406	55252406	1	GUARD	
55252413	55252413	1	GUARD	
56157399	56157399	1	HOLDER	
56157481	56157481	1	SPACER	
56157482	56157482	1	HOOD HINGE	
56157485	56157485	1	SUPPORTO TAMPONI YANMAR	
56157539	56157539	1	PIN	
56157590	56157590	1	HOOD HINGE	
56157603	56157603	1	HOLDER	
58042111	58042111	1	STOPPER	
58056991	58056991	1	CABLE GLAND	
58057385	58057385	1	LINE	
58135120	58135120	1	CABLE GLAND	
59052239	59052239	1	COMPLETE BUMPERS	
59052322	59052322	1	SUPPORT	
59053222	59053222	1	COMPLETE BUMPERS	
59057477	59057477	1	SUPPORT	

SERIAL

ENGINE PROTECTIONS (340)

CODE REV

001_6_63810

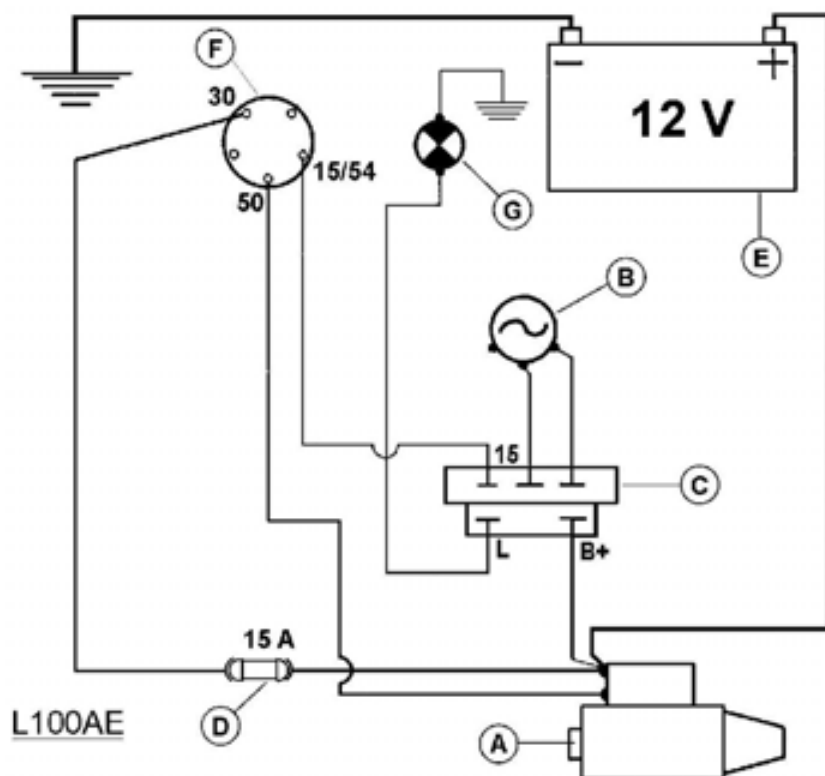

L100AE

A	B	C	D
MOTORINO D'AVVIAMENTO STARTER DÉMARREUR MOT. DE ARRANQUE ANLASSMOTOR	GENERATORE GENERATOR GÉNÉRATEUR GENERADOR GENERATOR	REGOLATORE REGULATOR RÉGULATEUR REGULADOR REGLER	FUSIBILI FUSES FUSIBLES FUSIBLES SCHMELZSICHERUNGEN

E	F	G
BATTERIA BATTERY BATTERIE BATERIA BATTERIE	INTERRUTTORE SWITCH INTERRUPTEUR INTERRUPTOR SCHALTER	SPIA CARICA BATTERIA BATTERY LONG WARN. LIGHT TEMOIN CHARG. BATTERIE LUZ CARGA BATERIA BATTERIELADUNG KTRL. LAMPE

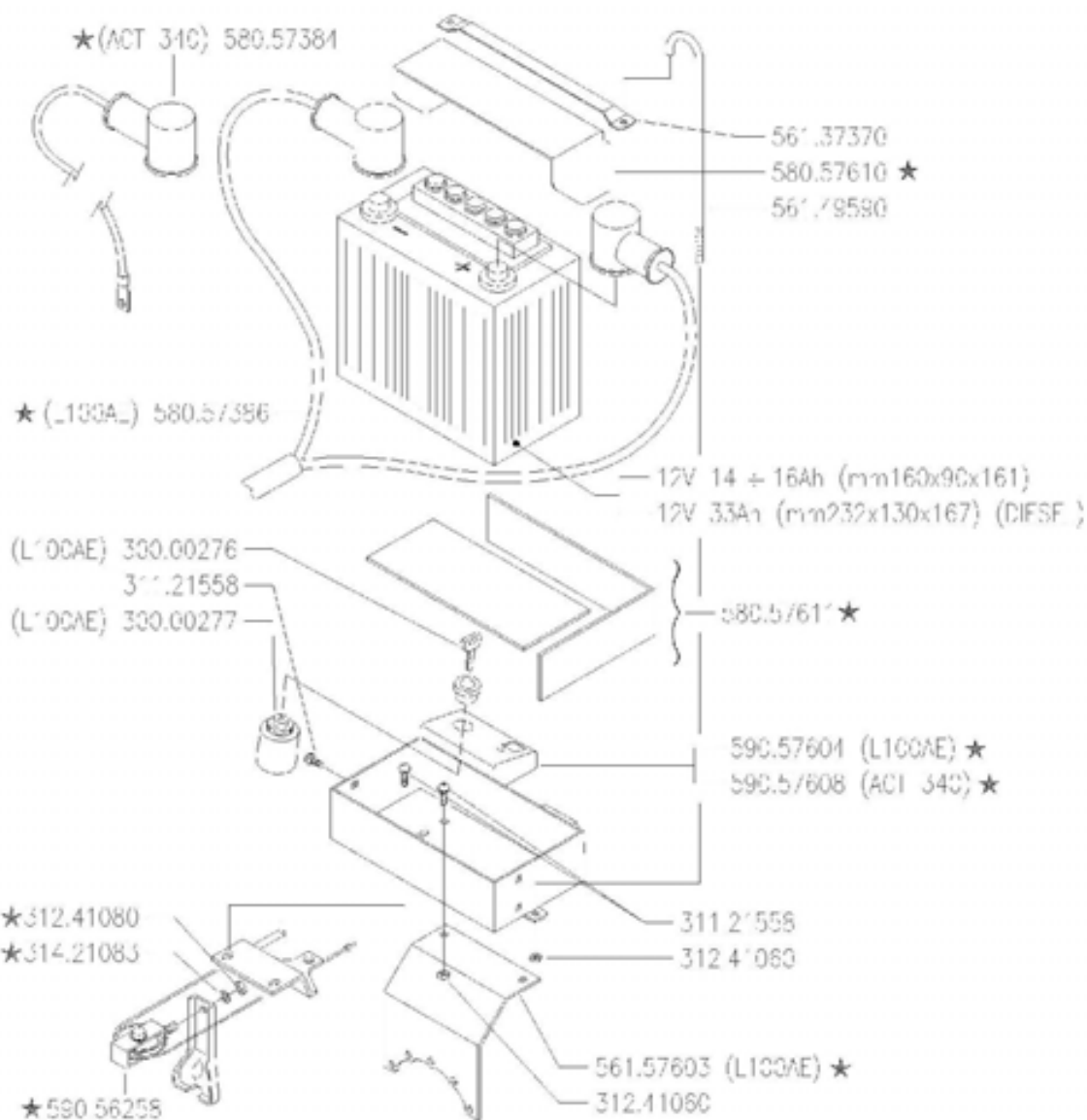

FERRARI

300 serie 95

AVVIAMENTO ELETTRICO (340)

ELECTRIC STARTER
ARRANQUE ELECTRICO

DÉMARRAGE ÉLECTRIQUE
ELEKTROSTART

DALLA MACCHINA
DE LA MAQUINA
DE LA MACHINE
FROM THE MACHINE
AB DER MASCHINE

AGGIORNAMENTO
REVISION
MISE A JOUR
APLAZAMENTO
ANPASSUNG

02

02

1/2000

★N.

28/95

Pos.	Code	Q.ty	Description	Notes
30000276	30000276	0	KEY	
30000277	30000277	0	SWITCH	
31121558	31121558	0	SCREW TTQ M6X16 UNI 5731	
31241060	31241060	0	SELFLOCK NUT M6	
31241080	31241080	0	SELFLOCK NUT M8	
31421083	31421083	0	WASHER	
56137370	56137370	0	BATTERY BRACKET	
56149590	56149590	0	BATTERY BRACKET	
56157603	56157603	0	HOLDER	
58057384	58057384	0	CABLE	
58057386	58057386	0	WIRING	
58057610	58057610	0	BOX	
58057611	58057611	0	KIT	
59056258	59056258	0	CLUTCH FORK	
59057604	59057604	0	BOX	
59057608	59057608	0	BOX	

Pos.	Code	Q.ty	Description	Notes
30000276	30000276	0	KEY	
30000277	30000277	0	SWITCH	
31121558	31121558	0	SCREW TTQ M6X16 UNI 5731	
31241060	31241060	0	SELFLOCK NUT M6	
31241080	31241080	0	SELFLOCK NUT M8	
31421083	31421083	0	WASHER	
56137370	56137370	0	BATTERY BRACKET	
56149590	56149590	0	BATTERY BRACKET	
56157603	56157603	0	HOLDER	
58045804	58045804	0	WARNING LIGHT	
58057384	58057384	0	CABLE	
58057386	58057386	0	WIRING	
58057610	58057610	0	BOX	
58057611	58057611	0	KIT	
59056258	59056258	0	CLUTCH FORK	
59057604	59057604	0	BOX	
59057608	59057608	0	BOX	

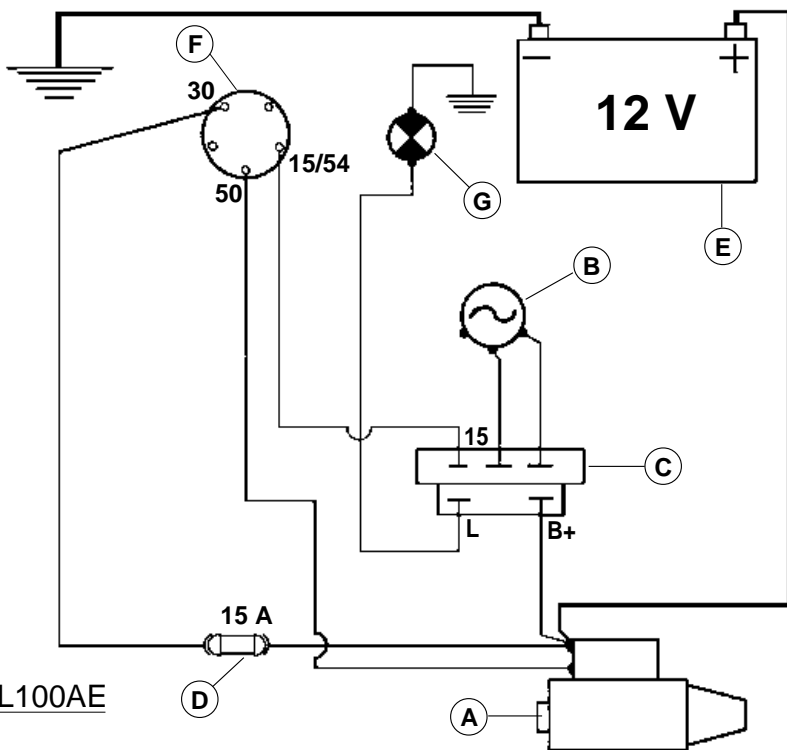

L100AE

A	B	C	D
MOTORINO D' AVVIAMENTO STARTER DÉMARREUR MOT. DE ARRANQUE ANLASSMOTOR	GENERATORE GENERATOR GÉNÉRATEUR GENERADOR GENERATOR	REGOLATORE REGULATOR RÉGULATEUR REGULADOR REGLER	FUSILI FUSES FUSIBLES FUSIBLES SCHMELZSICHERUNGEN

E	F	G 580.45804
BATTERIA BATTERY BATTERIE BATERIA BATTERIE	INTERRUTTORE SWITCH INTERRUPTEUR INTERRUPTOR SCHALTER	SPIA CARICA BATTERIA BATTERY LONG WARN. LIGHT TEMOIN CHARG. BATTERIE LUZ CARGA BATERIA BATTERIELADUNG KTRL. LAMPE

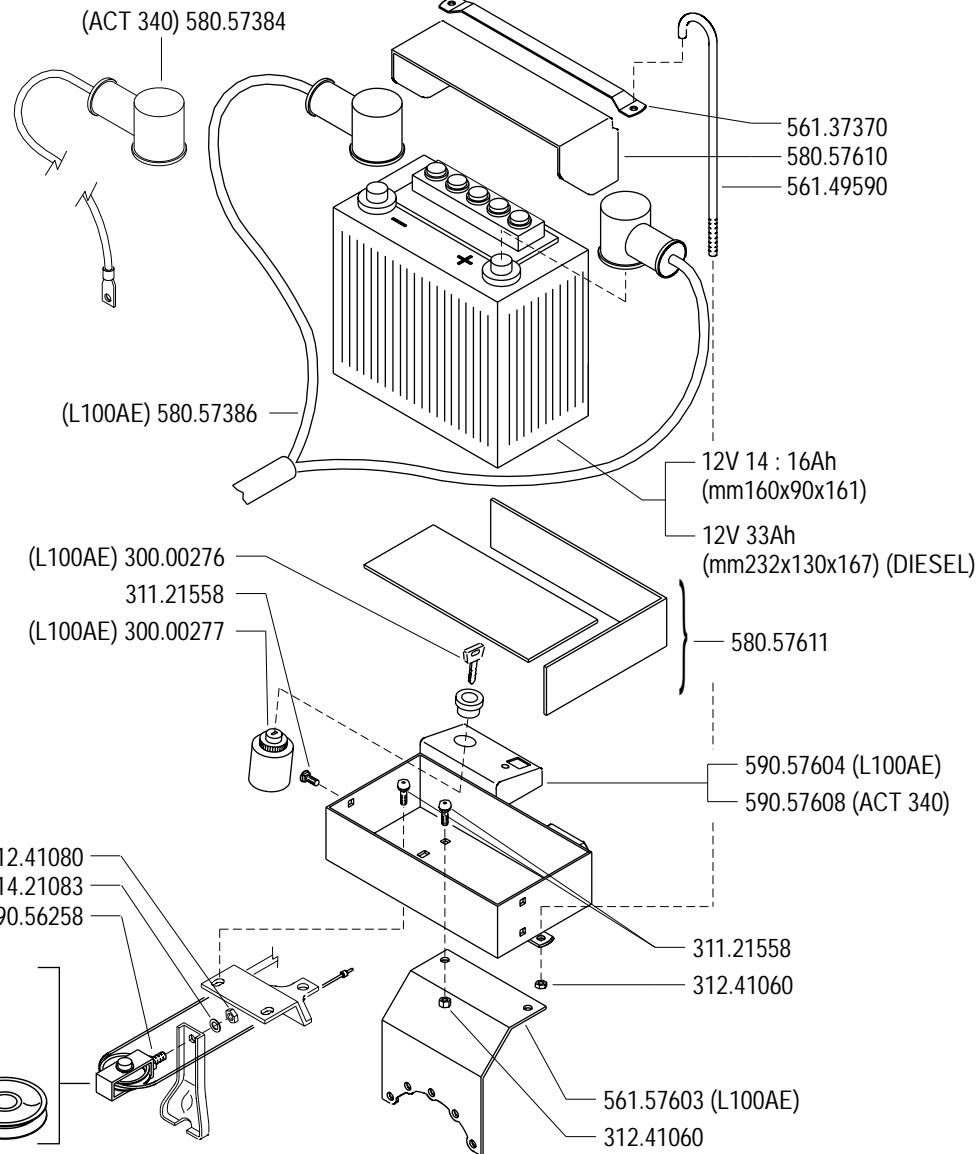
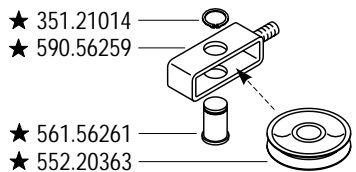

FERRARI

300 serie 95

AVVIAMENTO ELETTRICO (340)

ELECTRIC STARTER
ARRANQUE ELECTRICO

DÉMARRAGE ÉLECTRIQUE
ELEKTROSTART

DALLA MACCHINA
FROM THE MACHINE
DE LA MACHINE
DE LA MAQUINA
AB DER MASCHINE

AGGIORNAMENTO
REVISION
MISE A JOUR
APLAZAMIENTO
ANPASSUNG

02 4

07/2005

★N.

ZENNE

Pos.	Code	Q.ty	Description	Notes
30000276	30000276	0	KEY	
30000277	30000277	0	SWITCH	
31121558	31121558	0	SCREW TTQ M6X16 UNI 5731	
31241060	31241060	0	SELFLOCK NUT M6	
31241080	31241080	0	SELFLOCK NUT M8	
31421083	31421083	0	WASHER	
35121014	35121014	1	SEEGER RING E 14 DIN 471	
55220363	55220363	1	PULLEY	
56137370	56137370	0	BATTERY BRACKET	
56149590	56149590	0	BATTERY BRACKET	
56156261	56156261	1	PIN	
56157603	56157603	0	HOLDER	
58045804	58045804	0	WARNING LIGHT	
58057384	58057384	0	CABLE	
58057386	58057386	0	WIRING	
58057610	58057610	0	BOX	
58057611	58057611	0	KIT	
59056258	59056258	0	CLUTCH FORK	
59056259	59056259	1	CLUTCH FORK	
59057604	59057604	0	BOX	
59057608	59057608	0	BOX	

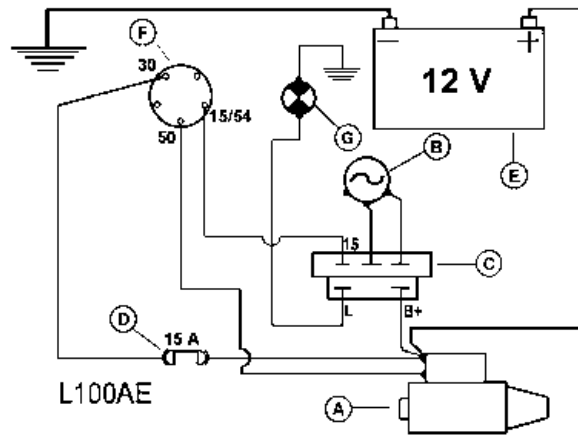
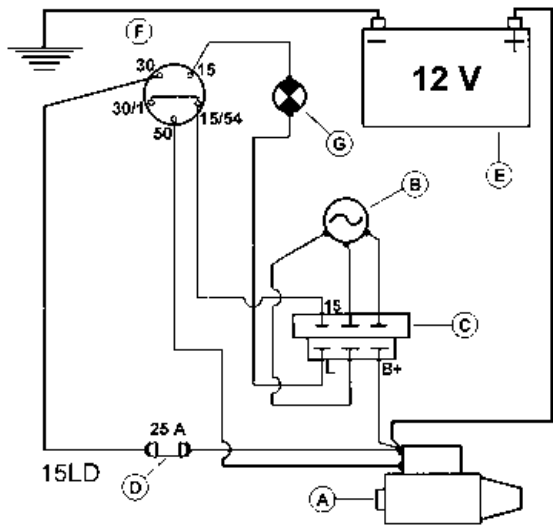

(ACT340) 58057384

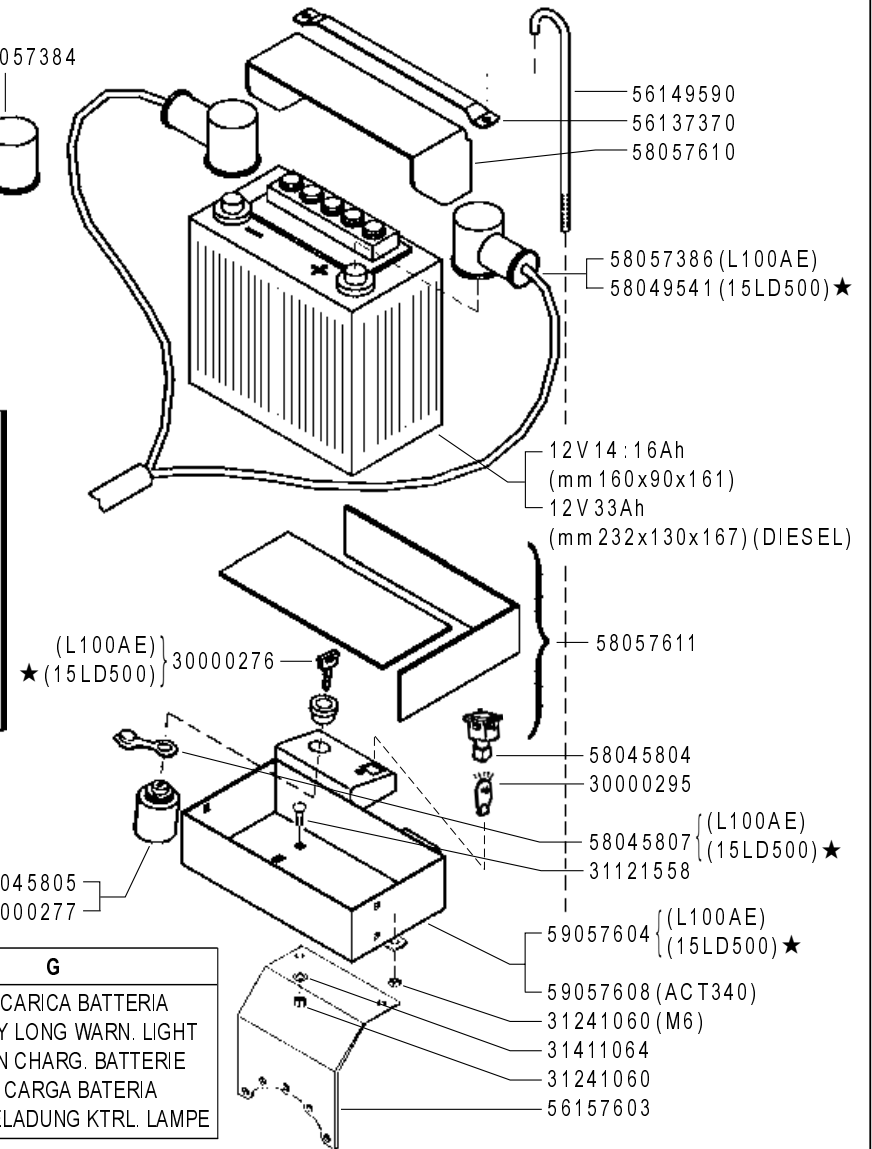

★(15LD500) 58045805
(L100AE) 30000277

A	B	C	D	E	F	G
MOTORINO D'AVVIAMENTO STARTER DÉMARREUR MOT. DE ARRANQUE ANLASSMOTOR	GENERATORE GENERATOR GÉNÉRATEUR GENERADOR GENERATOR	REGOLATORE REGULATOR RÉGULATEUR REGULADOR REGLER	FUSIBILI FUSES FUSIBLES FUSIBLES SCHMELZSICHERUNGEN	BATTERIA BATTERY BATTERIE BATERIA BATTERIE	INTERRUTTORE SWITCH INTERRUPTEUR INTERRUPTOR SCHALTER	SPIA CARICA BATTERIA BATTERY LONG WARN. LIGHT TEMOIN CHARG. BATTERIE LUZ CARGA BATERIA BATTERIELADUNG KTRL. LAMPE

FERRARI

300 serie 95

AVVIAMENTO ELETTRICO (340-346)

ELECTRIC STARTER
ARRANQUE ELECTRICO

DÉMARRAGE ÉLECTRIQUE
ELEKTROSTART

DALLA MACCHINA
DE LA MAQUINA
FROM THE MACHINE
AB DER MASCHINE

★N.

752002 (346)
749391 (340)

02 5

02/2006

ZENNE

Pos.	Code	Q.ty	Description	Notes
30000276	30000276	1	KEY	
30000277	30000277	1	SWITCH	
30000295	30000295	1	LAMP	
31121558	31121558	1	SCREW TTQ M6X16 UNI 5731	
31241060	31241060	1	SELFLOCK NUT M6	
31411064	31411064	1	WASHER 6,4x12,5	
56137370	56137370	1	BATTERY BRACKET	
56149590	56149590	1	BATTERY BRACKET	
56157603	56157603	1	HOLDER	
58045804	58045804	1	WARNING LIGHT	
58045805	58045805	1	SWITCH	
58045807	58045807	1	LOCK COVER	
58049541	58049541	1	WIRING	
58057384	58057384	1	CABLE	
58057386	58057386	1	WIRING	
58057610	58057610	1	BOX	
58057611	58057611	1	KIT	
59057604	59057604	1	BOX	
59057608	59057608	1	BOX	

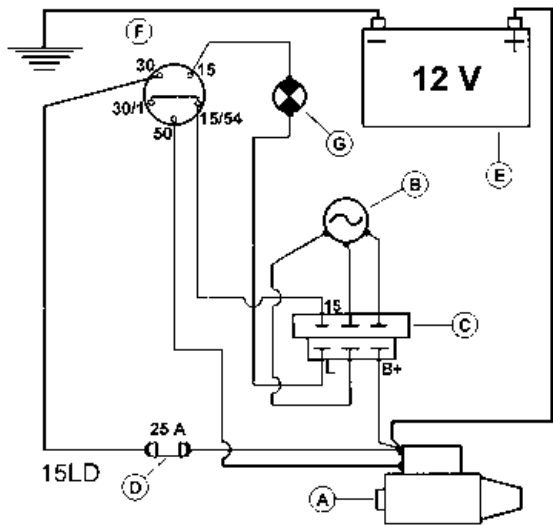

(ACT340) 58057384

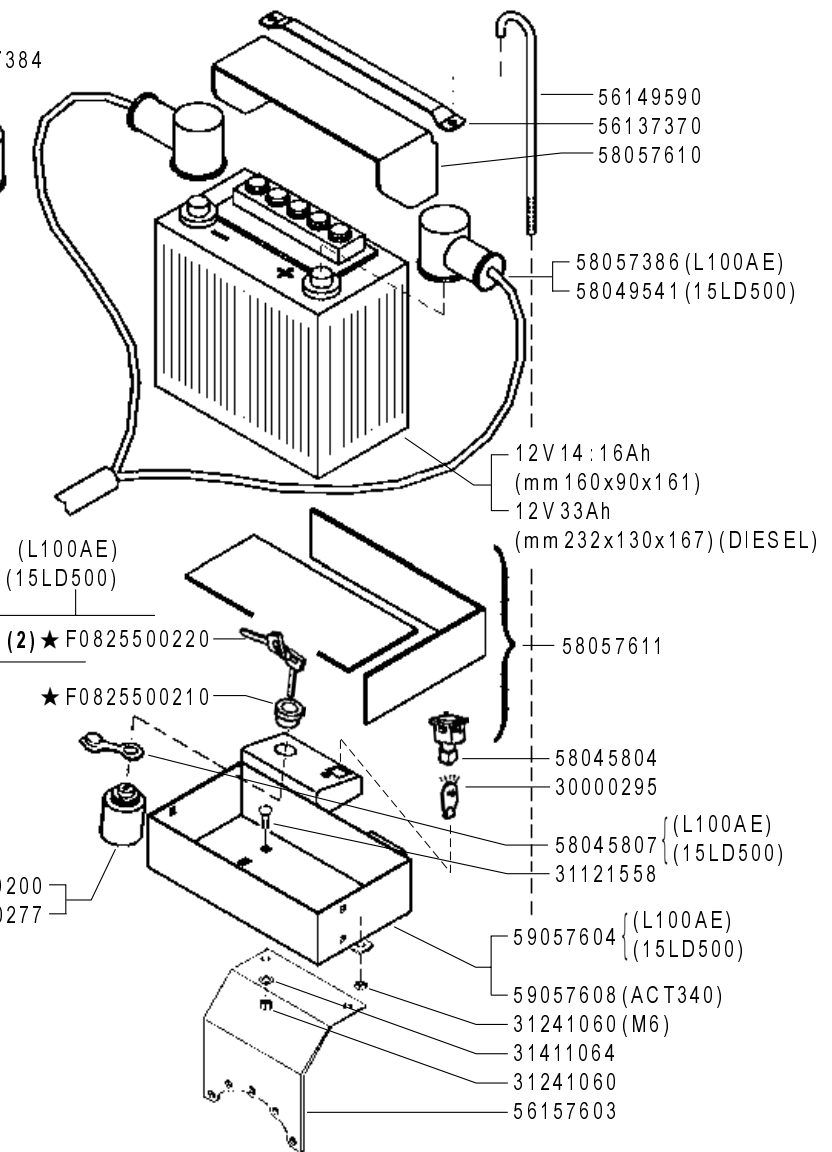
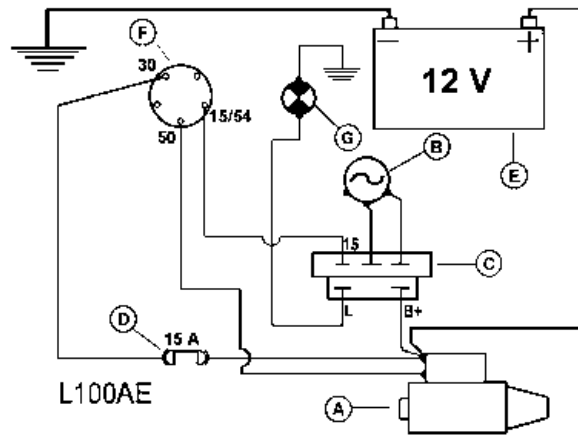

A	B	C
MOTORINO D'AVVIAMENTO STARTER DÉMARREUR MOT. DE ARRANQUE ANLASSMOTOR	GENERATORE GENERATOR GÉNÉRATEUR GENERADOR GENERATOR	REGOLATORE REGULATOR RÉGULATEUR REGULADOR REGLER

D	E	F	G
FUSIBILI FUSES FUSIBLES FUSIBLES SCHMELZSICHERUNGEN	BATTERIA BATTERY BATTERIE BATERIA BATTERIE	INTERRUTTORE SWITCH INTERRUPTEUR INTERRUPTOR SCHALTER	SPIA CARICA BATTERIA BATTERY LONG WARN. LIGHT TEMOIN CHARG. BATTERIE LUZ CARGA BATERIA BATTERIELADUNG KTRL. LAMPE

(2) sostituisce 30000276

(1) sostituisce 58045805

FERRARI

300 serie 95

AVVIAMENTO ELETTRICO (340-346)

ELECTRIC STARTER
ARRANQUE ELECTRICO

DÉMARRAGE ÉLECTRIQUE
ELEKTROSTART

DALLA MACCHINA
DE LA MAQUINA
DE LA MACHINE
FROM THE MACHINE
AB DER MASCHINE

AGGIORNAMENTO

REVISION

MISE A JOUR

APLZAMIENTO

ANPASSUNG

02

Rev.
6

01/2007

★ N.

ZENNE

Pos.	Code	Q.ty	Description	Notes
30000277	30000277	1	SWITCH	
30000295	30000295	1	LAMP	
31121558	31121558	1	SCREW TTQ M6X16 UNI 5731	
31241060	31241060	1	SELFLOCK NUT M6	
31411064	31411064	1	WASHER 6,4x12,5	
56137370	56137370	1	BATTERY BRACKET	
56149590	56149590	1	BATTERY BRACKET	
56157603	56157603	1	HOLDER	
58045804	58045804	1	WARNING LIGHT	
58045807	58045807	1	LOCK COVER	
58049541	58049541	1	WIRING	
58057384	58057384	1	CABLE	
58057386	58057386	1	WIRING	
58057610	58057610	1	BOX	
58057611	58057611	1	KIT	
59057604	59057604	1	BOX	
59057608	59057608	1	BOX	
F0825500	F0825500200	1	CHANGE-OVER SWITCH	
F0825500	F0825500210	1	RING NUT	
F0825500	F0825500220	1	KEY	

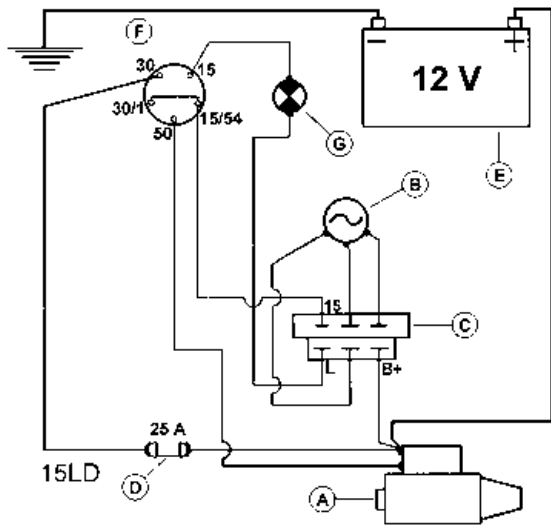

(ACT340) 58057384

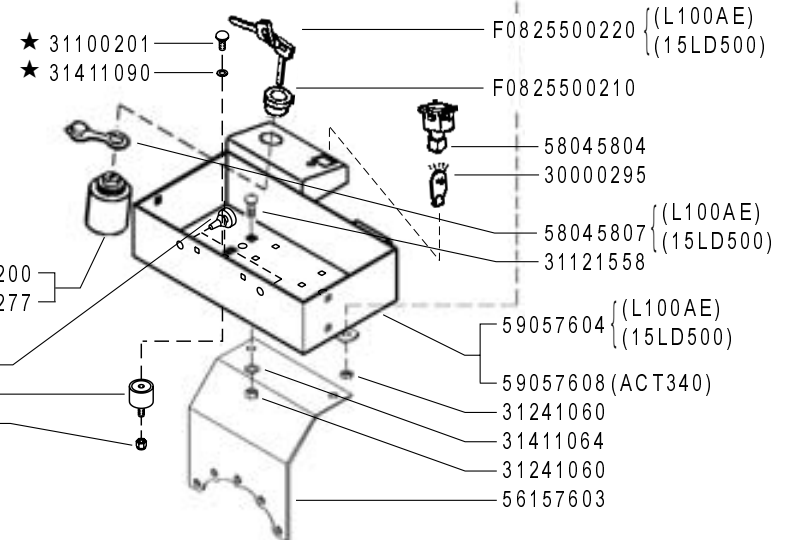
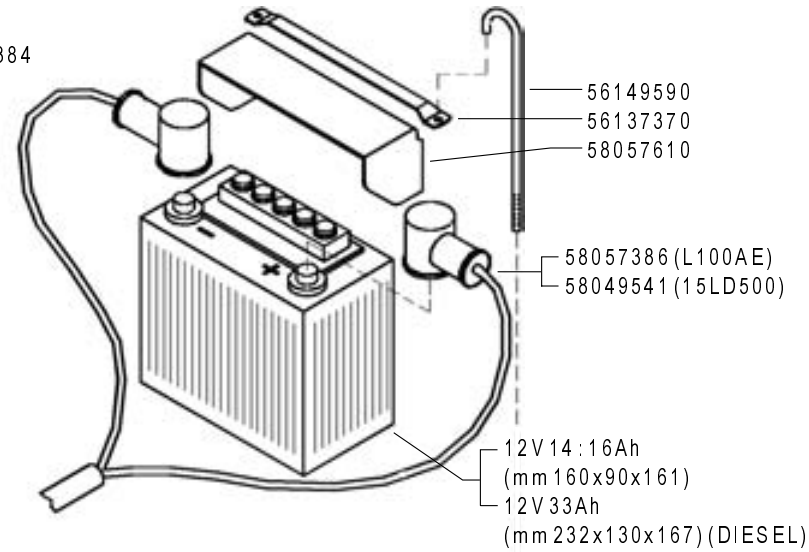
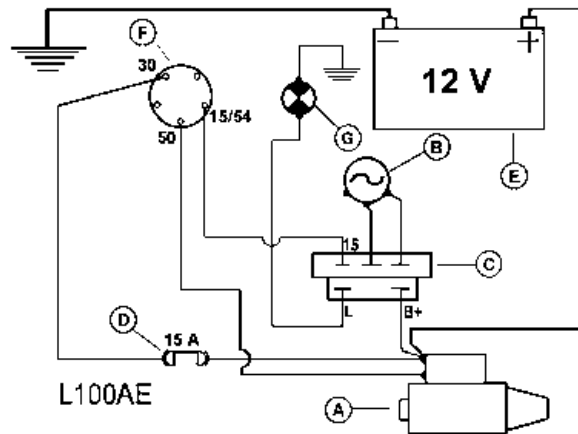

A	B	C
MOTORINO D'AVVIAMENTO STARTER DÉMARREUR MOT. DE ARRANQUE ANLASSMOTOR	GENERATORE GENERATOR GÉNÉRATEUR GENERADOR GENERATOR	REGOLATORE REGULATOR RÉGULATEUR REGULADOR REGLER

D	E	F	G
FUSIBILI FUSES FUSIBLES FUSIBLES SCHMELZSICHERUNGEN	BATTERIA BATTERY BATTERIE BATERIA BATTERIE	INTERRUTTORE SWITCH INTERRUPTEUR INTERRUPTOR SCHALTER	SPIA CARICA BATTERIA BATTERY LONG WARN. LIGHT TEMOIN CHARG. BATTERIE LUZ CARGA BATERIA BATTERIELADUNG KTRL. LAMPE

FERRARI

300 serie 95

AVVIAMENTO ELETTRICO (340-346)

ELECTRIC STARTER
ARRANQUE ELECTRICO

DÉMARRAGE ÉLECTRIQUE
ELEKTROSTART

DALLA MACCHINA
DE LA MAQUINA
DE LA MACHINE
FROM THE MACHINE
AB DER MASCHINE

★ N.

(346) 813168

(340) 823957

02

Rev.
7

01/2008

ZENNE

Pos.	Code	Q.ty	Description	Notes
30000277	30000277	1	SWITCH	
30000295	30000295	1	LAMP	
31100201	31100201	1	SCREW TTQ M6X12 UNI 5731	
31121558	31121558	1	SCREW TTQ M6X16 UNI 5731	
31241060	31241060	1	SELFLOCK NUT M6	
31411064	31411064	1	WASHER 6,4x12,5	
31411090	31411090	1	WASHER 9x24	
56137370	56137370	1	BATTERY BRACKET	
56149590	56149590	1	BATTERY BRACKET	
56157603	56157603	1	HOLDER	
58045804	58045804	1	WARNING LIGHT	
58045807	58045807	1	LOCK COVER	
58049541	58049541	1	WIRING	
58057384	58057384	1	CABLE	
58057386	58057386	1	WIRING	
58057610	58057610	1	BOX	
58057611	58057611	1	KIT	
58135225	58135225	1	VIBRATION-DAMPING	
58157405	58157405	1	PLUG	
59057604	59057604	1	BOX	
59057608	59057608	1	BOX	
F0825500	F0825500200	1	CHANGE-OVER SWITCH	
F0825500	F0825500210	1	RING NUT	
F0825500	F0825500220	1	KEY	

SERIAL

ELECTRIC STARTER (340 - 346)

Version: MC 346, MC 340

CODE REV

002_7_63846

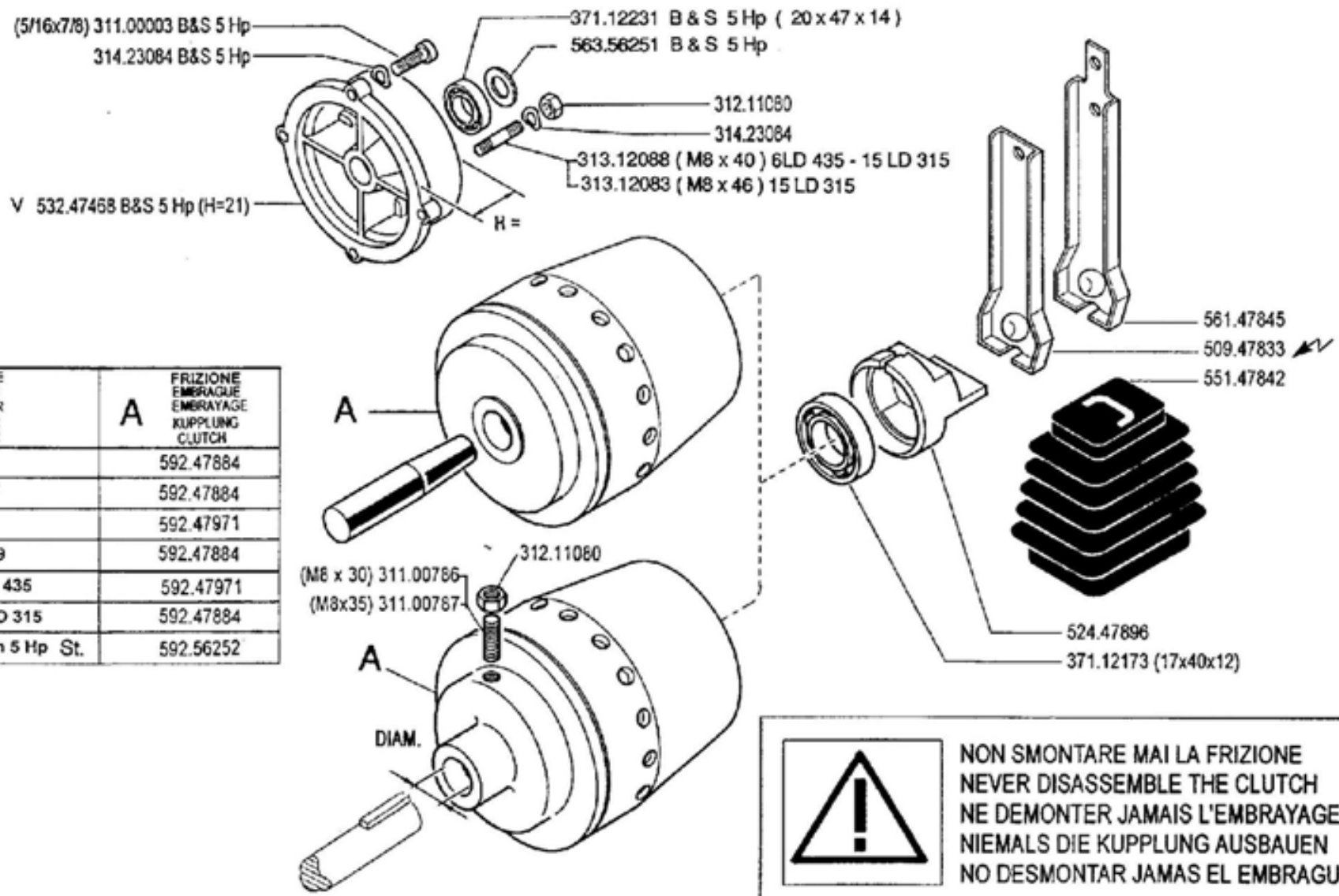

MOTORE ENGINF MOTEUR MOTOR	A	FRIZIONE EMBRAGUE EMBRAYAGE KUPPLUNG CLUTCH
Acme A220		592.47884
Acme ALN 330W		592.47884
Acme AT 330 W		592.47971
Intermotor IM 359		592.47884
Lombardini 6 LD 435		592.47971
Lombardini 15 LD 315		592.47884
Briggs & Stratton 5 Hp St.		592.56252

V = verde - vert - green - grün

**! NON SMONTARE MAI LA FRIZIONE
NEVER DISASSEMBLE THE CLUTCH
NE DEMONTER JAMAIS L'EMBRAYAGE
NIEMALS DIE KUPPLUNG AUSBAUEN
NO DESMONTAR JAMAS EL EMBRAGUE**

FERRARI

300 serie **95**

FRIZIONE A CONO AUTOVENTILANTE

EMBRAGUE
EMBRAYAGE

CLUTCH
KUPPLUNG

DALLA MACCHINA
DE LA MAQUINA
DE LA MACHINE
FROM THE MACHINE
AS DER MASCHINE

N.

03.00

01.06.1995

Pos.	Code	Q.ty	Description	Notes
31100003	31100003	0	SCREW TE 5/16X7/8	
31100786	31100786	0	SCREW STEI M8X30 UNI5923 8G	
31100787	31100787	0	SCREW STEI M8X35 UNI5923 8G	
31211080	31211080	0	NUT M8	
31312083	31312083	0	STUD BOLT M8X46X16X16	
31312088	31312088	0	STUD BOLT M8X40X14X14	
31423084	31423084	0	SPRING WASHER 8,4	
37112173	37112173	0	BEARING	
37112231	37112231	0	BEARING	
50947833	50947833	0	CLUTCH LEVER	
52447896	52447896	0	PRESSURE PLATE	
53247468	53247468	0	FLANGE	
55147842	55147842	0	BELLOWS	
56147845	56147845	0	CLUTCH LEVER	
56356251	56356251	0	SHIM D=19,6	
59247884	59247884	0	CLUTCH ASSY	
59247971	59247971	0	CLUTCH	
59256252	59256252	0	CLUTCH ASSY	

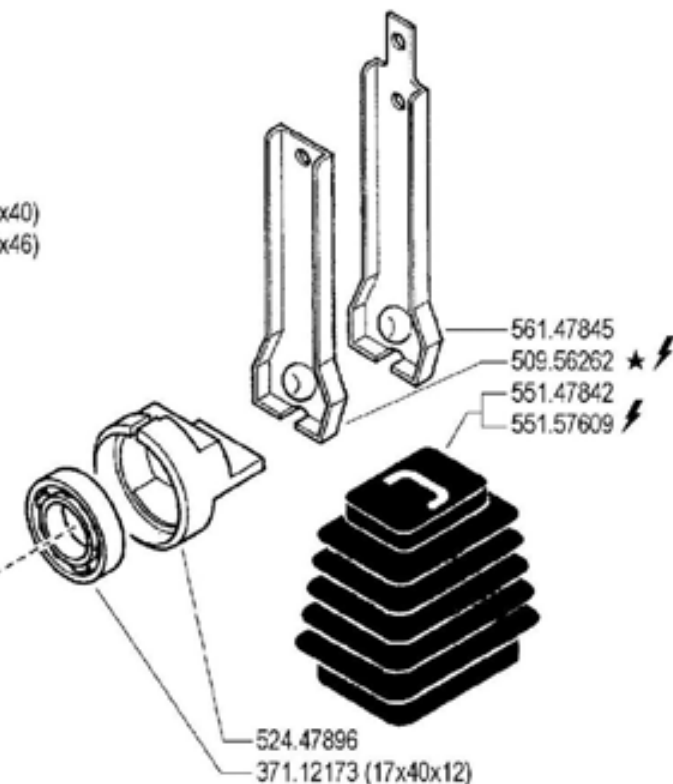
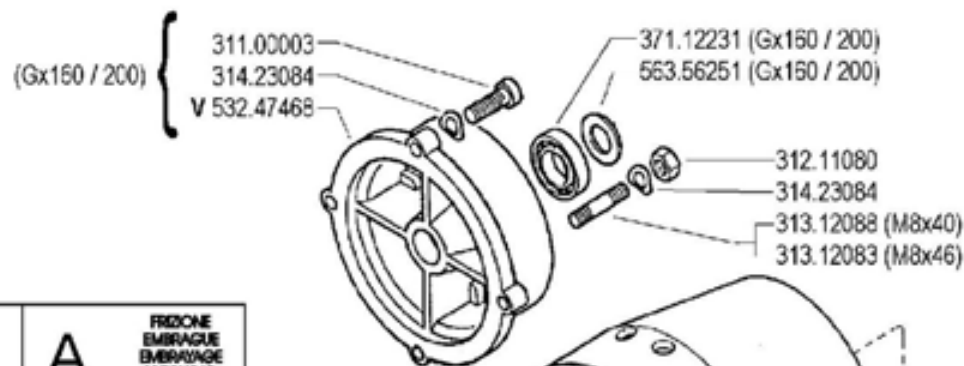

MOTORE ENGINE MOTELR MOTOR	A	FRIZIONE EMBRAGUE EMBRAYAGE KUPPLUNG CLUTCH
Acme A 220	592.47884	
Acme ALN 330W - ACT 280 ★	592.47884	
Acme AT 330W - ACT 340 ★	592.47971	
Honda Gx 160 / 200 ★	592.56252	
Intermotor IM 359	592.47884	
Lombardini 6 LD 435	592.47971	
Lombardini 15 LD 315 / 350	592.47884	
Yanmar L100 AE ★	592.47971	

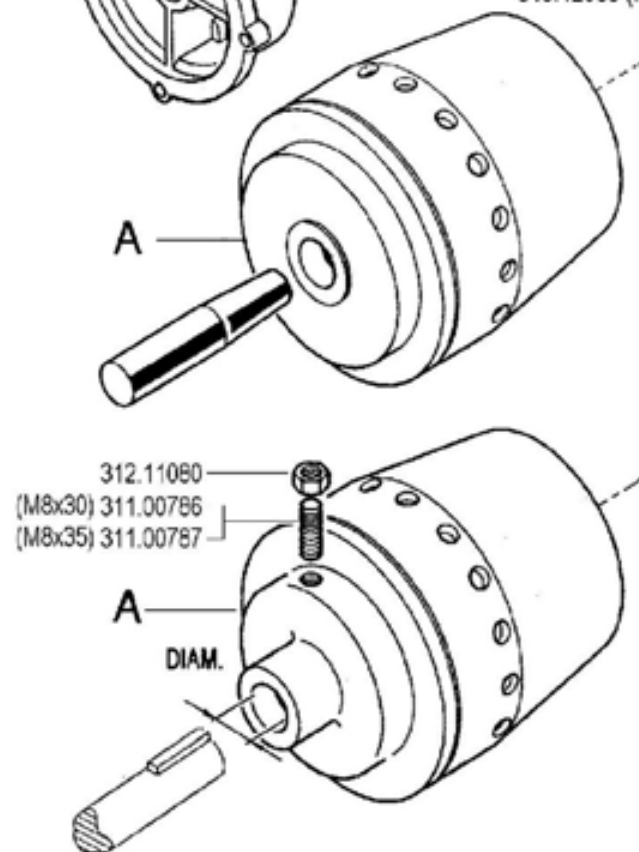



**NON SMONTARE MAI LA FRIZIONE
NEVER DISASSEMBLE THE CLUTCH
NE DEMONTER JAMAIS L'EMBRAYAGE
NIEMALS DIE KUPPLUNG AUSBAUEN
NO DESMONTAR JAMAS EL FMBRAGUE**

V = verde - green - vert - grün

FERRARI

300 serie 95

FRIZIONE A CONO AUTOVENTILANTE

CLUTCH
EMBRAGUE

EMBRAYAGE
KUPPLUNG

DALLA MACCHINA
DE LA MAQUINA
DE LA MACHINE
FROM THE MACHINE
AB DER MASCHINE

AGGIORNAMENTO

REVISION

MISE A JOUR

APLAZAMIENTO

ANPASSUNG

03

Vol.
01

1/2000

★N

REV. 01

Pos.	Code	Q.ty	Description	Notes
31100003	31100003	0	SCREW TE 5/16X7/8	
31100786	31100786	0	SCREW STEI M8X30 UNI5923 8G	
31100787	31100787	0	SCREW STEI M8X35 UNI5923 8G	
31211080	31211080	0	NUT M8	
31312083	31312083	0	STUD BOLT M8X46X16X16	
31312088	31312088	0	STUD BOLT M8X40X14X14	
31423084	31423084	0	SPRING WASHER 8,4	
37112173	37112173	0	BEARING	
37112231	37112231	0	BEARING	
50956262	50956262	0	CLUTCH LEVER	
52447896	52447896	0	PRESSURE PLATE	
53247468	53247468	0	FLANGE	
55147842	55147842	0	BELLOWS	
55157609	55157609	0	BELLOWS	
56147845	56147845	0	CLUTCH LEVER	
56356251	56356251	0	SHIM D=19,6	
59247884	59247884	0	CLUTCH ASSY	
59247971	59247971	0	CLUTCH	
59256252	59256252	0	CLUTCH ASSY	

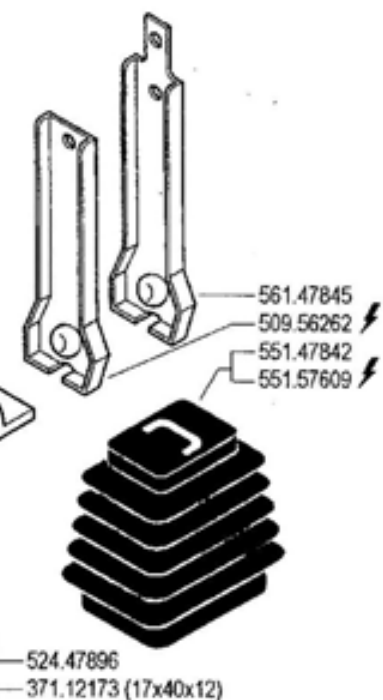

MOTORE ENGINE MOTEUR MOTOR	A	FRIZIONE EMBRAGUE KUPPLUNG CLUTCH
Acme A 220		592.47884
A349 ★ - A360 ★ - ACT 280		592.47884
ACT 340		592.47971
Honda Gx 160 / 200		592.56265 ★ (1)
Intermotor IM 359		592.47884
Lombardini 6 LD 435		592.47971
Lombardini 15 LD 315 / 350		592.47884
Yanmar L100 AE		592.47971

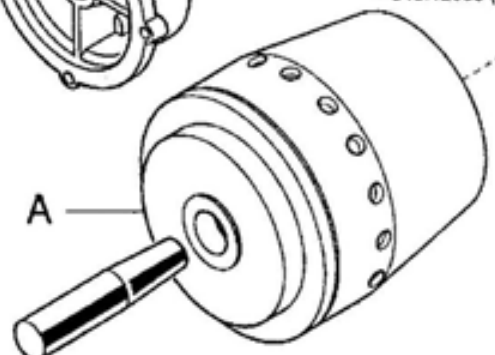

- (B) 312.11080
- (B) (M8x30) 311.00786
- (B) (M8x35) 311.00787

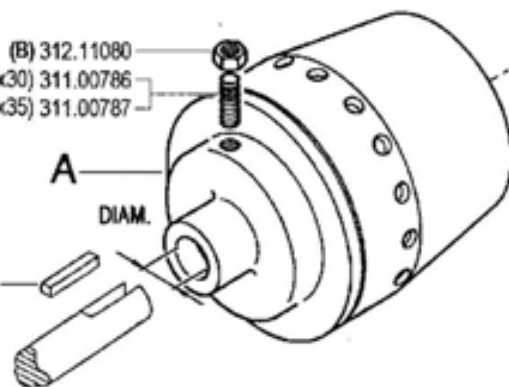

NON SMONTARE MAI LA FRIZIONE
NEVER DISASSEMBLE THE CLUTCH
NE DEMONTER JAMAIS L'EMBRAYAGE
NIEMALS DIE KUPPLUNG AUSBAUEN
NO DESMONTAR JAMAS EL FMBRAGUE

(1) sostituisce 592.56252

(*) serrare a 2 kgm.

FERRARI	300 serie 95	FRIZIONE A CONO AUTOVENTILANTE		DALLA MACCHINA DE LA MAQUINA DE LA MACHINE FROM THE MACHINE AB DER MASCHINE	AGGIORNAMENTO	03	Rev. 2
		CLUTCH EMBRAGUE	EMBRAYAGE KUPPLUNG		REVISION		
				★ N.	MISE A JOUR	10/2001	
				ANPASSUNG	AFIJAZAMENTO		

Pos.	Code	Q.ty	Description	Notes
31100003	31100003	0	SCREW TE 5/16X7/8	
31100786	31100786	0	SCREW STEI M8X30 UNI5923 8G	
31100787	31100787	0	SCREW STEI M8X35 UNI5923 8G	
31211080	31211080	0	NUT M8	
31312083	31312083	0	STUD BOLT M8X46X16X16	
31312088	31312088	0	STUD BOLT M8X40X14X14	
31423084	31423084	0	SPRING WASHER 8,4	
37112173	37112173	0	BEARING	
37112231	37112231	0	BEARING	
50956262	50956262	0	CLUTCH LEVER	
52447896	52447896	0	PRESSURE PLATE	
53247468	53247468	0	FLANGE	
55147842	55147842	0	BELLOWS	
55157609	55157609	0	BELLOWS	
56147845	56147845	0	CLUTCH LEVER	
56356165	56356165	0	DOWEL	
56356251	56356251	0	SHIM D=19,6	
59247884	59247884	0	CLUTCH ASSY	
59247971	59247971	0	CLUTCH	
59256265	59256265	0	CLUTCH ASSY	

- ★(Gx240/270) 31100015
(Gx160/200) 31100003
- ★(Gx240/270) 53156150
(Gx160/200) 53247468
- ★(Gx240/270) 31423105
(Gx160/200) 31423084
- ★(Gx240/270) 37112233
(Gx160/200) 37112231
- 56347484 (Gx240/270) ★
- 56356251 (Gx160/200)
- 31211080
- 31241080 ⚡
- 31423084
- 31312088 (M8x40)
- 31312083 (M8x46)

MOTORE ENGINE MOTEUR MOTOR	A	FRIZIONE CLUTCH EMBRAYAGE EMBRAGUE KUPPLUNG
AcmeA220		59247884
A349 - A360 - ACT280		59247884
ACT340		59247971
Honda Gx160/200		59256271 ★(1)
Honda Gx240/270 ★		59256253
Lombardini 15LD315/350		59247884
Lombardini 15LD500 ★		59247924
Yanmar L70AE ★		59247884
Yanmar L100AE		59247971

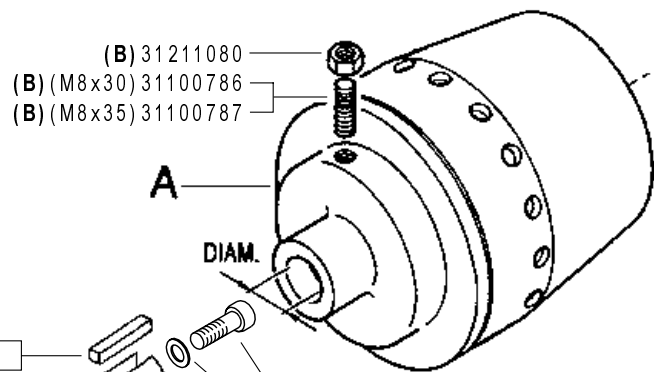
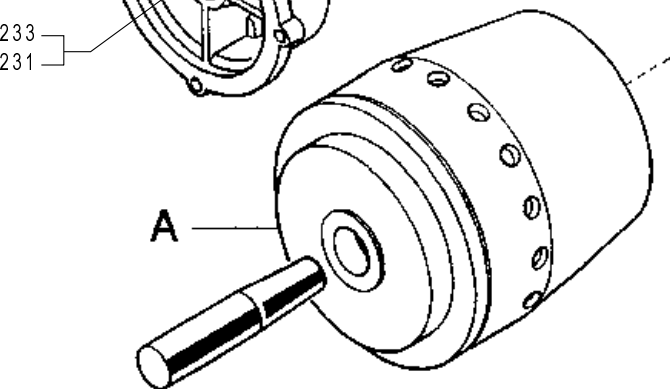

- ★(Gx240/270) 56349782
(Gx160/200) 56356165

- 31104020 ★
- 31411084 ★ } Gx160/200

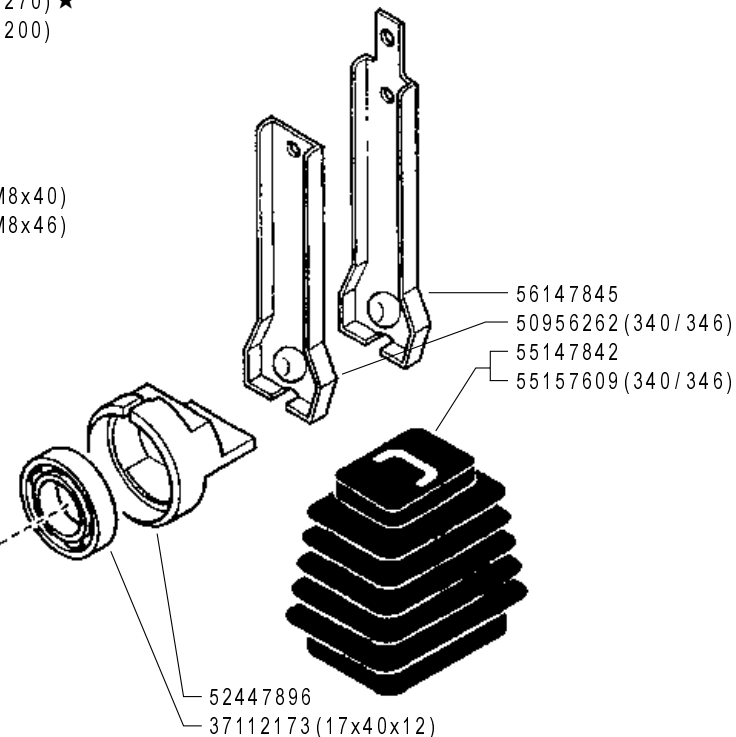

NON SMONTARE MAI LA FRIZIONE
NEVER DISASSEMBLE THE CLUTCH
NE DEMONTER JAMAIS L'EMBRAYAGE
NIEMALS DIE KUPPLUNG AUSBAUEN
NO DESMONTAR JAMAS EL EMBRAGUE

(1) sostituisce 59256265

ZEMNE

FERRARI	300 serie 95	FRIZIONE A CONO AUTOVENTILANTE		DALLA MACCHINA DE LA MAQUINA FROM THE MACHINE AB DER MASCHINE	Rev.	03	3
		CLUTCH	EMBRAYAGE		(1) 763195		
		EMBRAGUE	KUPPLUNG		752002 (346)		
					749391 (340)		
				★ N.	02/2006		

Pos.	Code	Q.ty	Description	Notes
31100003	31100003	1	SCREW TE 5/16X7/8	
31100015	31100015	1	SCREW TE 3/8X1	
31100786	31100786	1	SCREW STEI M8X30 UNI5923 8G	
31100787	31100787	1	SCREW STEI M8X35 UNI5923 8G	
31104020	31104020	1	SCREW TCCE 5/16X3/4 24 UNF 12K	
31211080	31211080	1	NUT M8	
31241080	31241080	1	SELFLOCK NUT M8	
31312083	31312083	1	STUD BOLT M8X46X16X16	
31312088	31312088	1	STUD BOLT M8X40X14X14	
31411084	31411084	1	WASHER 8,4x17	
31423084	31423084	1	SPRING WASHER 8,4	
31423105	31423105	1	SPRING WASHER 10,5	
37112173	37112173	1	BEARING	
37112231	37112231	1	BEARING	
37112233	37112233	1	BEARING	
50956262	50956262	1	CLUTCH LEVER	
52447896	52447896	1	PRESSURE PLATE	
53156150	53156150	1	ENGINE FLANGE	
53247468	53247468	1	FLANGE	
55147842	55147842	1	BELLOWS	
55157609	55157609	1	BELLOWS	
56147845	56147845	1	CLUTCH LEVER	
56347484	56347484	1	SHIM	
56349782	56349782	1	DOWEL	
56356165	56356165	1	DOWEL	
56356251	56356251	1	SHIM D=19,6	
59247884	59247884	1	CLUTCH ASSY	
59247924	59247924	1	CLUTCH	
59247971	59247971	1	CLUTCH	
59256253	59256253	1	CLUTCH ASSY	

SERIAL

CLUTCH

Version: MC 346, MC 340

CODE REV

003_3_25078

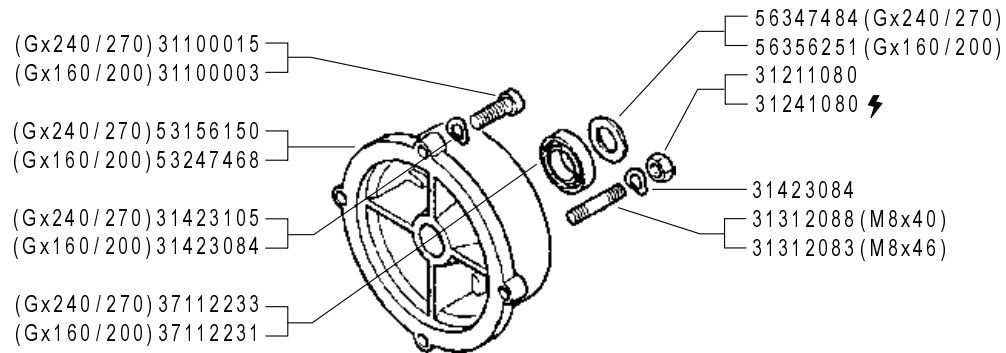

MOTORE ENGINE MOTEUR MOTOR	A	FRIZIONE CLUTCH EMBRAYAGE EMBRAGUE KUPPLUNG
AcmeA220		59247884
A349 - A360 - ACT280		59247884
ACT340		59247971
Honda Gx160/200 (D=19)		59256275 ★ (1)
Honda Gx240/270 (D=25,4)		59256279 ★ (2)
Lombardini 15LD315/350		59247884
Lombardini 15LD500		59247924
Yanmar L70AE		59247884
Yanmar L100AE		59247971

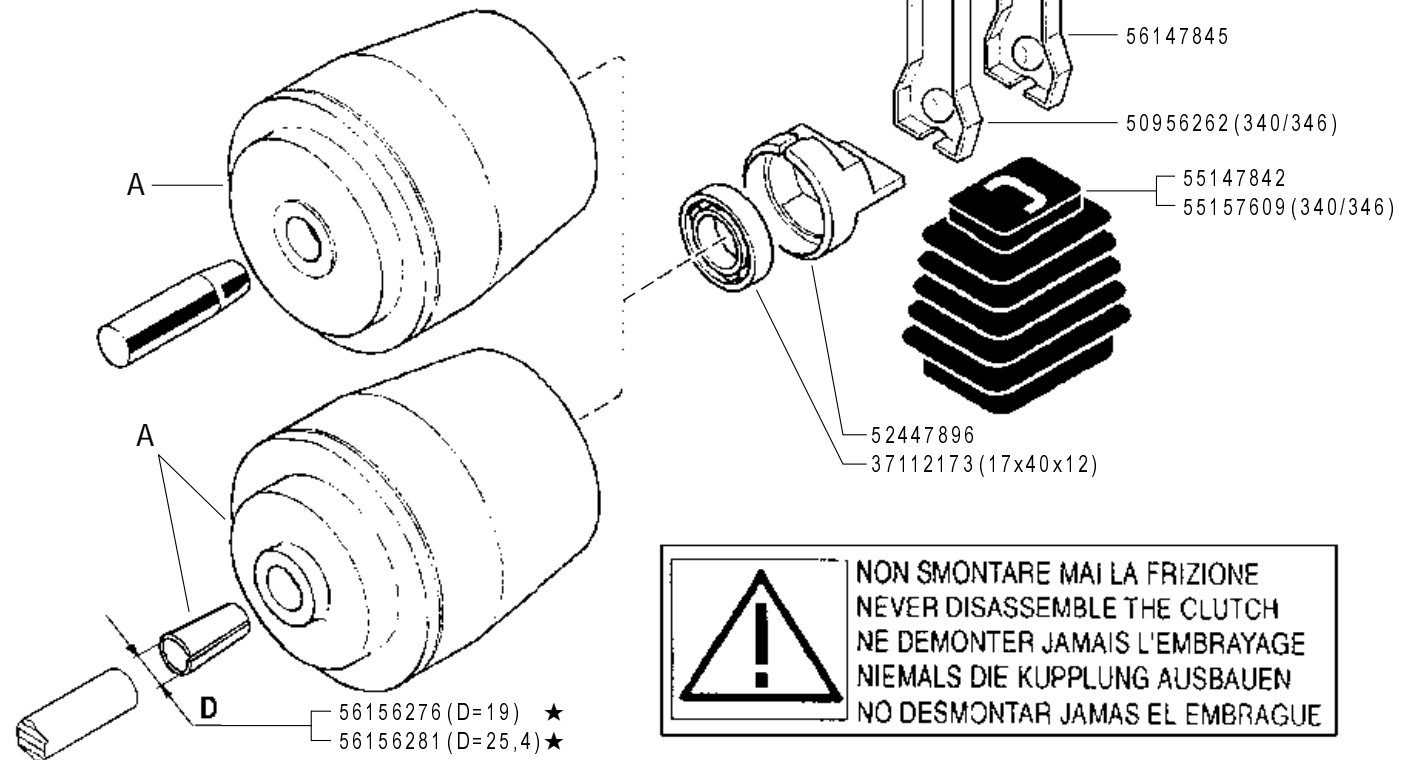

**NON SMONTARE MAI LA FRIZIONE
 NEVER DISASSEMBLE THE CLUTCH
 NE DEMONTER JAMAIS L'EMBRAYAGE
 NIEMALS DIE KUPPLUNG AUSBAUEN
 NO DESMONTAR JAMAS EL EMBRAGUE**

(2) sostituisce 59256253
 (1) sostituisce 59256271

	300 serie 95	FRIZIONE A CONO AUTOVENTILANTE CLUTCH EMBRAGUE EMBRAYAGE KUPPLUNG	DALLA MACCHINA DE LA MAQUINA DE LA MACHINE FROM THE MACHINE AB DER MASCHINE	CHIEDERE A S.A.T.	03	Rev. 4
				ASK TO S.A.T.		

★ N.

ZENNE

Pos.	Code	Q.ty	Description	Notes
31100003	31100003	1	SCREW TE 5/16X7/8	
31100015	31100015	1	SCREW TE 3/8X1	
31211080	31211080	1	NUT M8	
31241080	31241080	1	SELFLOCK NUT M8	
31312083	31312083	1	STUD BOLT M8X46X16X16	
31312088	31312088	1	STUD BOLT M8X40X14X14	
31423084	31423084	1	SPRING WASHER 8,4	
31423105	31423105	1	SPRING WASHER 10,5	
37112173	37112173	1	BEARING	
37112231	37112231	1	BEARING	
37112233	37112233	1	BEARING	
50956262	50956262	1	CLUTCH LEVER	
52447896	52447896	1	PRESSURE PLATE	
53156150	53156150	1	ENGINE FLANGE	
53247468	53247468	1	FLANGE	
55147842	55147842	1	BELLOWS	
55157609	55157609	1	BELLOWS	
56147845	56147845	1	CLUTCH LEVER	
56156276	56156276	1	SLEEVE	
56156281	56156281	1	CENTRING BUSH	
56347484	56347484	1	SHIM	
56356251	56356251	1	SHIM D=19,6	
59247884	59247884	1	CLUTCH ASSY	
59247924	59247924	1	CLUTCH	
59247971	59247971	1	CLUTCH	
59256275	59256275	1	CLUTCH ASSY	
59256279	59256279	1	CLUTCH ASSY	

SERIAL

SELF-VENTILATING CONE CLUTCH

CODE REV

003_4_27606

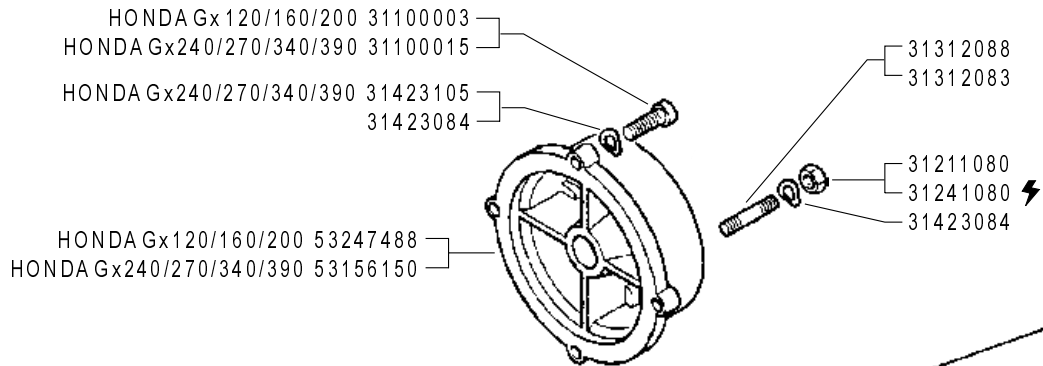

MOTORE ENGINE MOTEUR MOTOR	FRIZIONE CLUTCH A EMBRAYAGE EMBRAGUE KUPPLUNG
Acme A220	59247884
Acme A220 (REF.)	59256255
Acme ACT280 - A349 - A360	59247884
Acme ACT340	59247971
Honda Gx390 - Gx340 D=25,4	59256280
Honda Gx240/270 D=25,4	59256279
Honda Gx120/160/200 D=19	59256275
Lombardini 15LD315/350	59247884
Lombardini 15LD500	59247924
Yanmar L100AE	59247971
Yanmar L70AE	59247884

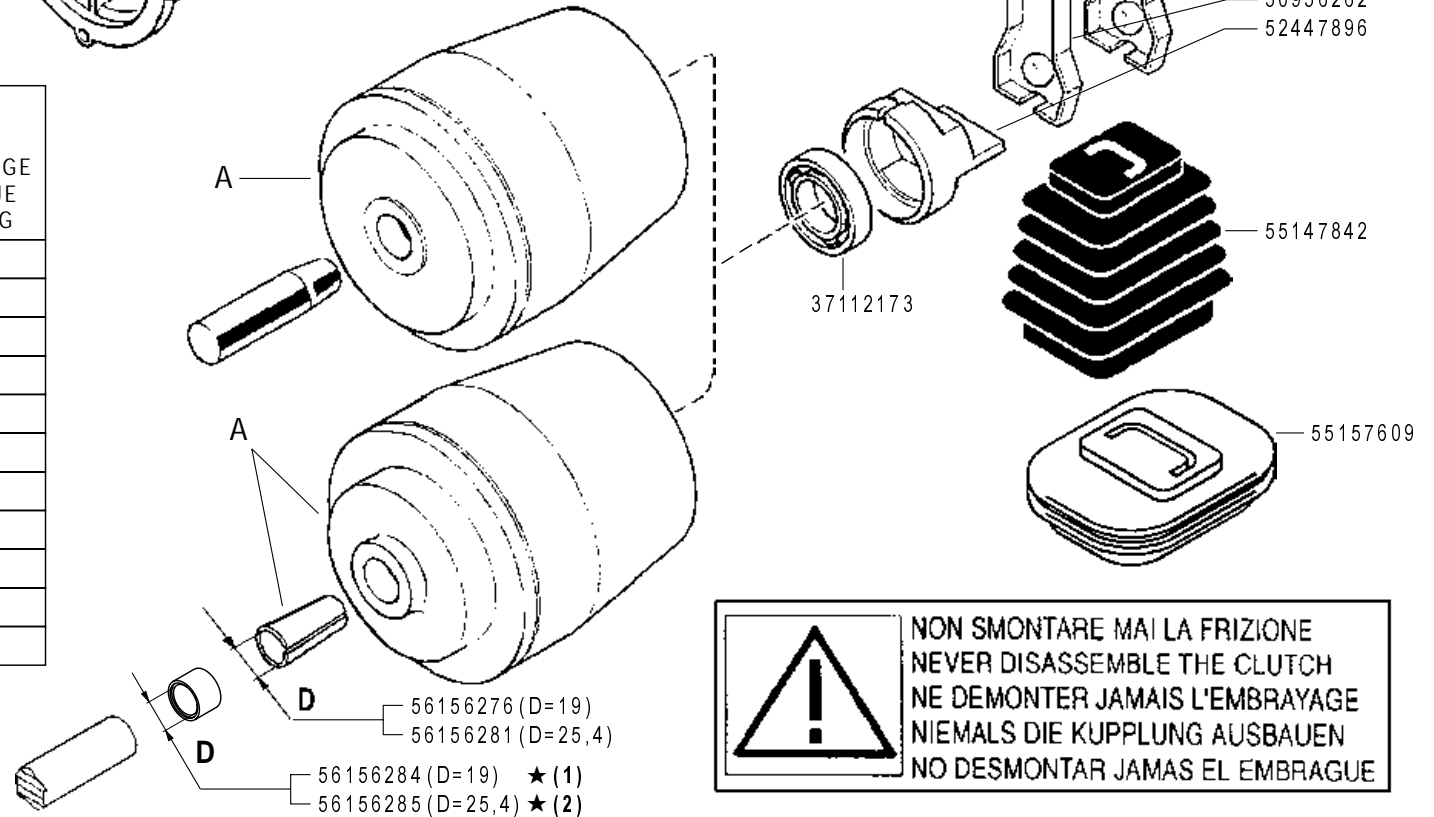

! NON SMONTARE MAI LA FRIZIONE
 NEVER DISASSEMBLE THE CLUTCH
 NE DEMONTER JAMAIS L'EMBRAYAGE
 NIEMALS DIE KUPPLUNG AUSBAUEN
 NO DESMONTAR JAMAS EL EMBRAGUE

FERRARI

300 serie 95

FRIZIONE A CONO AUTOVENTILANTE

CLUTCH
EMBRAGUE

EMBRAYAGE
KUPPLUNG

DALLA MACCHINA
DE LA MAQUINA
FROM THE MACHINE
AB DER MASCHINE

★ N.

(2) 799519
(1) 779324

03

Rev.
5

11/2006

ZENNE

Pos.	Code	Q.ty	Description	Notes
31100003	31100003	1	SCREW TE 5/16X7/8	
31100015	31100015	1	SCREW TE 3/8X1	
31211080	31211080	1	NUT M8	
31241080	31241080	1	SELFLOCK NUT M8	
31312083	31312083	1	STUD BOLT M8X46X16X16	
31312088	31312088	1	STUD BOLT M8X40X14X14	
31423084	31423084	1	SPRING WASHER 8,4	
31423105	31423105	1	SPRING WASHER 10,5	
37112173	37112173	1	BEARING	
50956262	50956262	1	CLUTCH LEVER	
52447896	52447896	1	PRESSURE PLATE	
53156150	53156150	1	ENGINE FLANGE	
53247488	53247488	1	ENGINE FLANGE	
55147842	55147842	1	BELLOWS	
55157609	55157609	1	BELLOWS	
56147845	56147845	1	CLUTCH LEVER	
56156276	56156276	1	SLEEVE	
56156281	56156281	1	CENTRING BUSH	
56156284	56156284	1	SPACER	
56156285	56156285	1	SPACER	
59247884	59247884	1	CLUTCH ASSY	
59247924	59247924	1	CLUTCH	
59247971	59247971	1	CLUTCH	
59256255	59256255	1	CLUTCH ASSY	
59256275	59256275	1	CLUTCH ASSY	
59256279	59256279	1	CLUTCH ASSY	
59256280	59256280	1	CLUTCH ASSY	

SERIAL

CLUTCH

CODE REV

003_5_33490

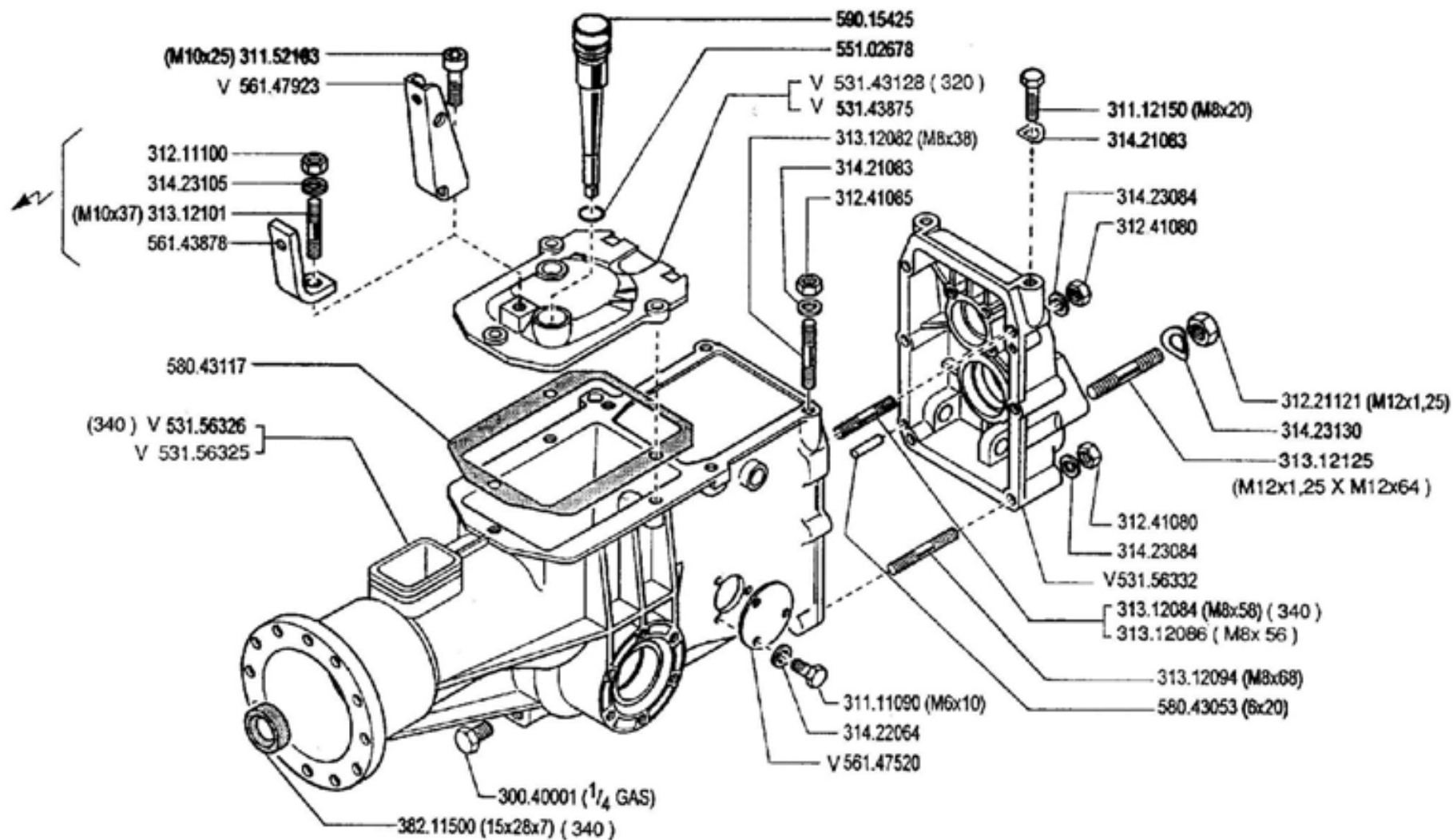

V = verde - vert - green - grün

FERRARI

300 serie **95**

SCATOLA CAMBIO

CAJA DE CAMBIO

BOITE DE VITESSES

GEARBOX

WECHSELGETRIEBE

DALLA MACCHINA
DE LA MAQUINA
DE LA MACHINE
FROM THE MACHINE
AS DER MASCHINE

N.

04.00

01.06.1995

Pos.	Code	Q.ty	Description	Notes
30040001	30040001	0	PLUG	
31111090	31111090	0	SCREW TE M5X10 UNI 5739 8G	
31112150	31112150	0	SCREW TE M8X20 UNI 5739 8G	
31152103	31152103	0	SCREW TCEI M10X25 UNI 5931	
31211100	31211100	0	NUT M10	
31221121	31221121	0	NUT M12X1,25	
31241080	31241080	0	SELFLOCK NUT M8	
31241085	31241085	0	SELFLOCK NUT M8 6S	
31312082	31312082	0	STUD BOLT M8X38X14X20	
31312084	31312084	0	STUD BOLT M8X58X16X16	
31312086	31312086	0	STUD BOLT M8X56X20X14	
31312094	31312094	0	STUD BOLT M8X68X14X36	
31312101	31312101	0	STUD BOLT M10X37X15X19	
31312125	31312125	0	STUD BOLT	
31421083	31421083	0	WASHER	
31422064	31422064	0	SPRING WASHER 6,4	
31423084	31423084	0	SPRING WASHER 8,4	
31423105	31423105	0	SPRING WASHER 10,5	
31423130	31423130	0	SPRING WASHER 13	
38211500	38211500	0	OIL SEAL 15X28X7	
53143128	53143128	0	COVER	
53143875	53143875	0	GEARBOX HOUSING COVER	
53156325	53156325	0	BODY	
53156326	53156326	0	BODY	
53156332	53156332	0	REAR COVER	
55102678	55102678	0	RUBBER RING	
56143878	56143878	0	BRACKET	
56147520	56147520	0	COVER	
56147923	56147923	0	BRACKET	
58043053	58043053	0	CYLINDRICAL PLUG	
58043117	58043117	0	COVER GASKET	
59015425	59015425	0	PLUG	

SERIAL

GEARBOX

CODE REV

004_0_10617

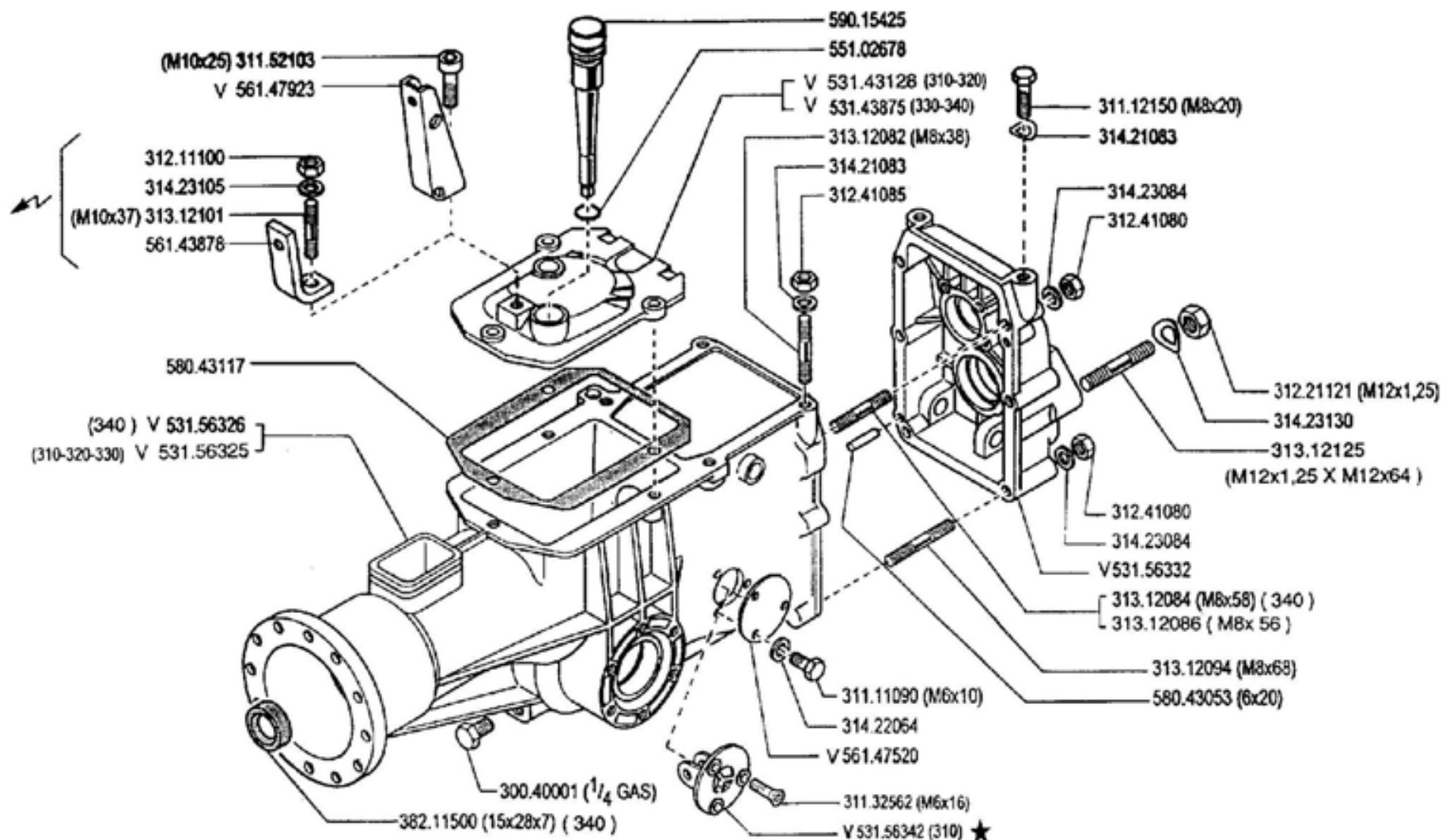

V = verde - vert - green - grün

FERRARI

300 serie **95**

CAJA DE CAMBIO
BOITE DE VITESSES

SCATOLA CAMBIO

GEARBOX
WECHSELGETRIEBE

DALLA MACCHINA
DE LA MAQUINA
DE LA MACHINE
FROM THE MACHINE
AB DER MASCHINE

AGGIORNAMENTO

REVISION

MISE A JOUR

APLAZAMIENTO

ANPASSUNG

04.01

9/1997

★ N.

Pos.	Code	Q.ty	Description	Notes
30040001	30040001	0	PLUG	
31111090	31111090	0	SCREW TE M5X10 UNI 5739 8G	
31112150	31112150	0	SCREW TE M8X20 UNI 5739 8G	
31132562	31132562	0	SCREW TSVEI M6X16 UNI 5933	
31152103	31152103	0	SCREW TCEI M10X25 UNI 5931	
31211100	31211100	0	NUT M10	
31221121	31221121	0	NUT M12X1,25	
31241080	31241080	0	SELFLOCK NUT M8	
31241085	31241085	0	SELFLOCK NUT M8 6S	
31312082	31312082	0	STUD BOLT M8X38X14X20	
31312084	31312084	0	STUD BOLT M8X58X16X16	
31312086	31312086	0	STUD BOLT M8X56X20X14	
31312094	31312094	0	STUD BOLT M8X68X14X36	
31312101	31312101	0	STUD BOLT M10X37X15X19	
31312125	31312125	0	STUD BOLT	
31421083	31421083	0	WASHER	
31422064	31422064	0	SPRING WASHER 6,4	
31423084	31423084	0	SPRING WASHER 8,4	
31423105	31423105	0	SPRING WASHER 10,5	
31423130	31423130	0	SPRING WASHER 13	
38211500	38211500	0	OIL SEAL 15X28X7	
53143128	53143128	0	COVER	
53143875	53143875	0	GEARBOX HOUSING COVER	
53156325	53156325	0	BODY	
53156326	53156326	0	BODY	
53156332	53156332	0	REAR COVER	
53156342	53156342	0	GEAR SUPPORT	
55102678	55102678	0	RUBBER RING	
56143878	56143878	0	BRACKET	
56147520	56147520	0	COVER	
56147923	56147923	0	BRACKET	
58043053	58043053	0	CYLINDRICAL PLUG	
58043117	58043117	0	COVER GASKET	
59015425	59015425	0	PLUG	

SERIAL

GEARBOX

CODE REV

004_1_10650

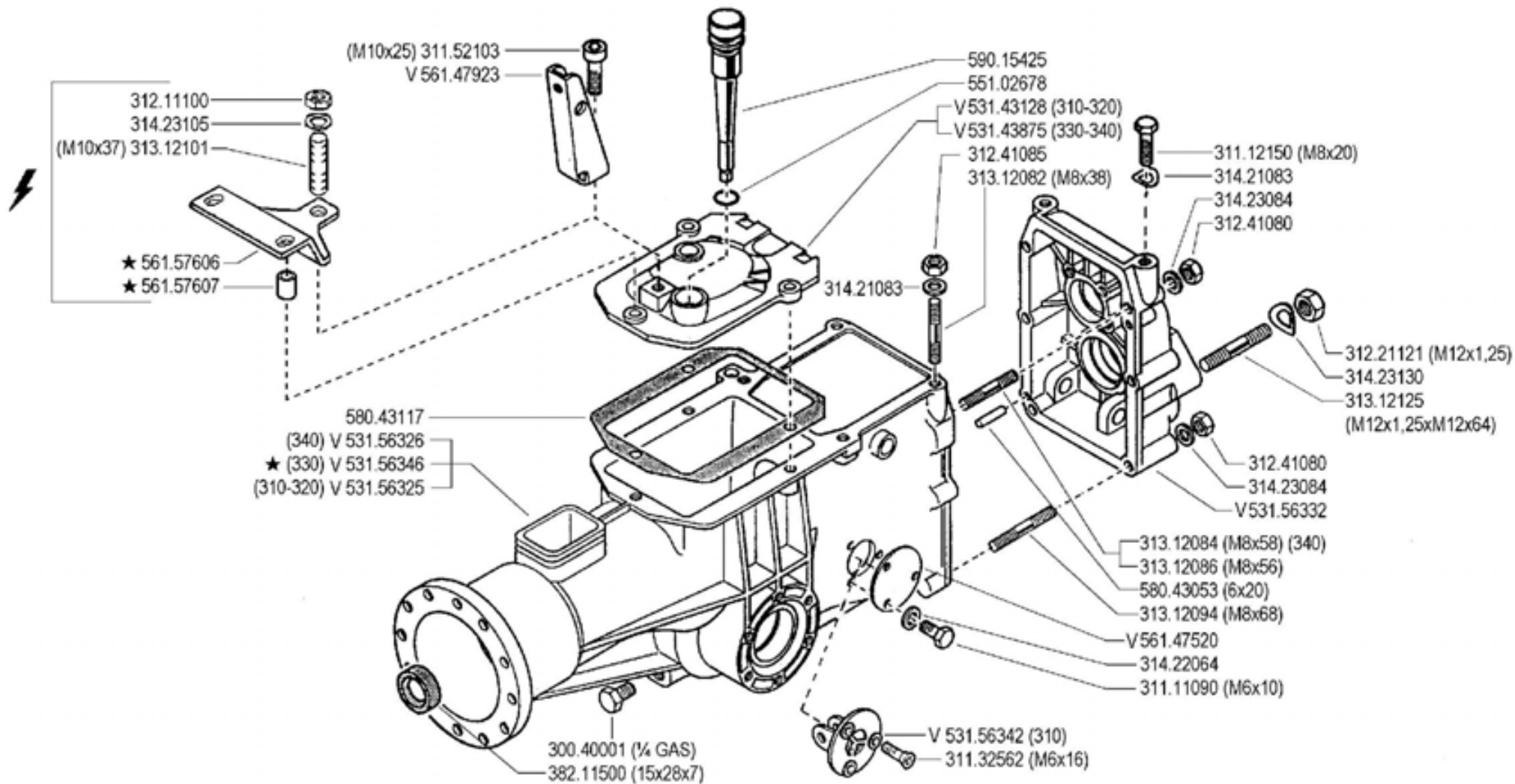

V = verde - green - vert - grün

FERRARI

300 serie 95

SCATOLA CAMBIO

GEARBOX
CAJA DE CAMBIO

BOITE DE VITESSES
WECHSELGETRIEBE

DALLA MACCHINA
DE LA MAQUINA
DE LA MACHINE
FROM THE MACHINE
AB DER MASCHINE

AGGIORNAMENTO

REVISION

MISE A JOUR

APLAZAMIENTO

ANPASSUNG

04

Vol.
02

1/2000

★N.

VERBA

Pos.	Code	Q.ty	Description	Notes
30040001	30040001	0	PLUG	
31111090	31111090	0	SCREW TE M5X10 UNI 5739 8G	
31112150	31112150	0	SCREW TE M8X20 UNI 5739 8G	
31132562	31132562	0	SCREW TSVEI M6X16 UNI 5933	
31152103	31152103	0	SCREW TCEI M10X25 UNI 5931	
31211100	31211100	0	NUT M10	
31221121	31221121	0	NUT M12X1,25	
31241080	31241080	0	SELFLOCK NUT M8	
31241085	31241085	0	SELFLOCK NUT M8 6S	
31312082	31312082	0	STUD BOLT M8X38X14X20	
31312084	31312084	0	STUD BOLT M8X58X16X16	
31312086	31312086	0	STUD BOLT M8X56X20X14	
31312094	31312094	0	STUD BOLT M8X68X14X36	
31312101	31312101	0	STUD BOLT M10X37X15X19	
31312125	31312125	0	STUD BOLT	
31421083	31421083	0	WASHER	
31422064	31422064	0	SPRING WASHER 6,4	
31423084	31423084	0	SPRING WASHER 8,4	
31423105	31423105	0	SPRING WASHER 10,5	
31423130	31423130	0	SPRING WASHER 13	
38211500	38211500	0	OIL SEAL 15X28X7	
53143128	53143128	0	COVER	
53143875	53143875	0	GEARBOX HOUSING COVER	
53156325	53156325	0	BODY	
53156326	53156326	0	BODY	
53156332	53156332	0	REAR COVER	
53156342	53156342	0	GEAR SUPPORT	
53156346	53156346	0	BODY	
55102678	55102678	0	RUBBER RING	
56147520	56147520	0	COVER	
56147923	56147923	0	BRACKET	
56157606	56157606	0	STOP	
56157607	56157607	0	SPACER	
58043053	58043053	0	CYLINDRICAL PLUG	

SERIAL

GEARBOX

CODE REV

004_2_10685

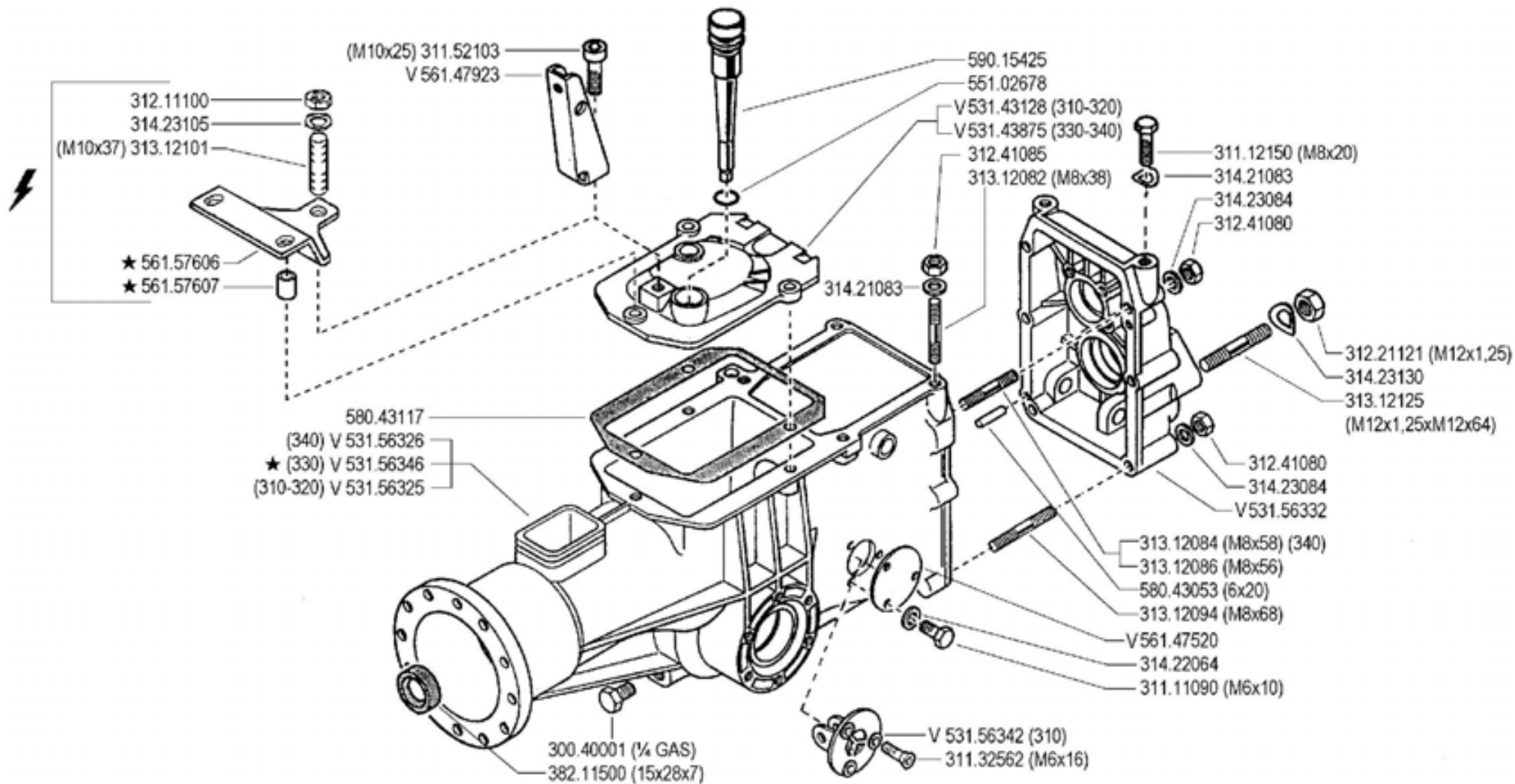

V = verde - green - vert - grün

FERRARI

300 serie 95

SCATOLA CAMBIO

GEARBOX
CAJA DE CAMBIO

BOITE DE VITESSES
WECHSELGETRIEBE

DALLA MACCHINA
DE LA MAQUINA
DE LA MACHINE
FROM THE MACHINE
AB DER MASCHINE

AGGIORNAMENTO

REVISION

MISE A JOUR

APLAZAMIENTO

ANPASSUNG

04

Vol.
02

1/2000

★N.

VERBA

Pos.	Code	Q.ty	Description	Notes
58043117	58043117	0	COVER GASKET	
59015425	59015425	0	PLUG	

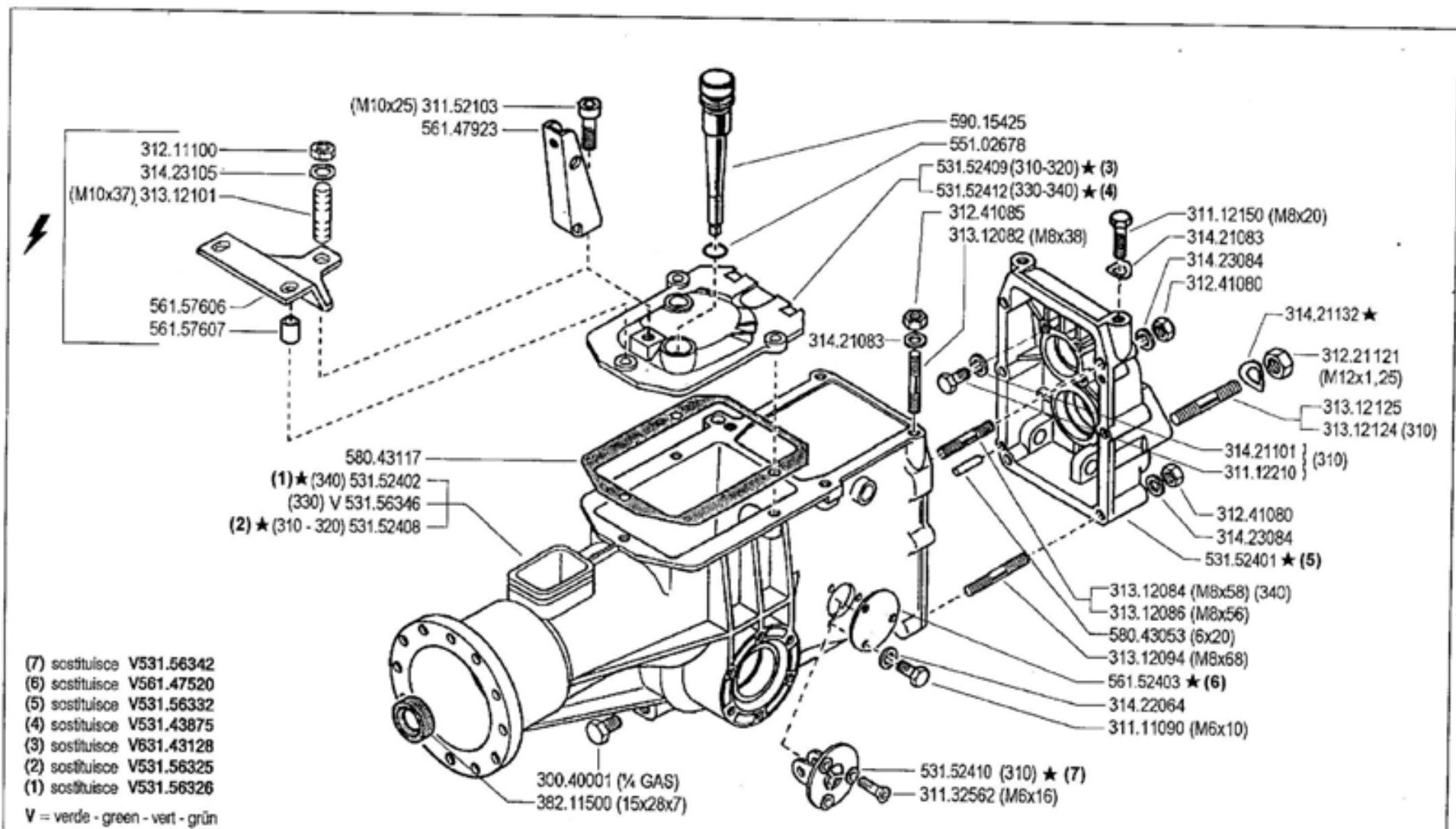

	300 serie 95	SCATOLA CAMBIO GEARBOX CAJA DE CAMBIO	DALLA MACCHINA DE LA MAQUINA FROM THE MACHINE AB DER MASCHINE	AGGIORNAMENTO	04	Rev.
				REVISION		3
				MISE A JOUR		
				APLAZAMIENTO		
			★N	ANPASSUNG	12/2002	

Pos.	Code	Q.ty	Description	Notes
30040001	30040001	0	PLUG	
31111090	31111090	0	SCREW TE M5X10 UNI 5739 8G	
31112150	31112150	0	SCREW TE M8X20 UNI 5739 8G	
31112210	31112210	0	SCREW TE M10X20 UNI 5739	
31132562	31132562	0	SCREW TSVEI M6X16 UNI 5933	
31152103	31152103	0	SCREW TCEI M10X25 UNI 5931	
31211100	31211100	0	NUT M10	
31221121	31221121	0	NUT M12X1,25	
31241080	31241080	0	SELFLOCK NUT M8	
31241085	31241085	0	SELFLOCK NUT M8 6S	
31312082	31312082	0	STUD BOLT M8X38X14X20	
31312084	31312084	0	STUD BOLT M8X58X16X16	
31312086	31312086	0	STUD BOLT M8X56X20X14	
31312094	31312094	0	STUD BOLT M8X68X14X36	
31312101	31312101	0	STUD BOLT M10X37X15X19	
31312124	31312124	0	STUD BOLT	
31312125	31312125	0	STUD BOLT	
31421083	31421083	0	WASHER	
31421101	31421101	0	WASHER	
31421132	31421132	0	WASHER 13X24X2,8	
31422064	31422064	0	SPRING WASHER 6,4	
31423084	31423084	0	SPRING WASHER 8,4	
31423105	31423105	0	SPRING WASHER 10,5	
38211500	38211500	0	OIL SEAL 15X28X7	
53143128	53143128	0	COVER	
53143875	53143875	0	GEARBOX HOUSING COVER	
53152401	53152401	0	REAR COVER	
53152402	53152402	0	BODY	
53152408	53152408	0	BODY	
53152409	53152409	0	COVER	
53152410	53152410	0	GEAR SUPPORT	
53152412	53152412	0	COPERCHIO SCAT.CAMBIO DIFF.*V*	
53156325	53156325	0	BODY	
53156326	53156326	0	BODY	

SERIAL

GEARBOX

CODE REV

004_3_10722

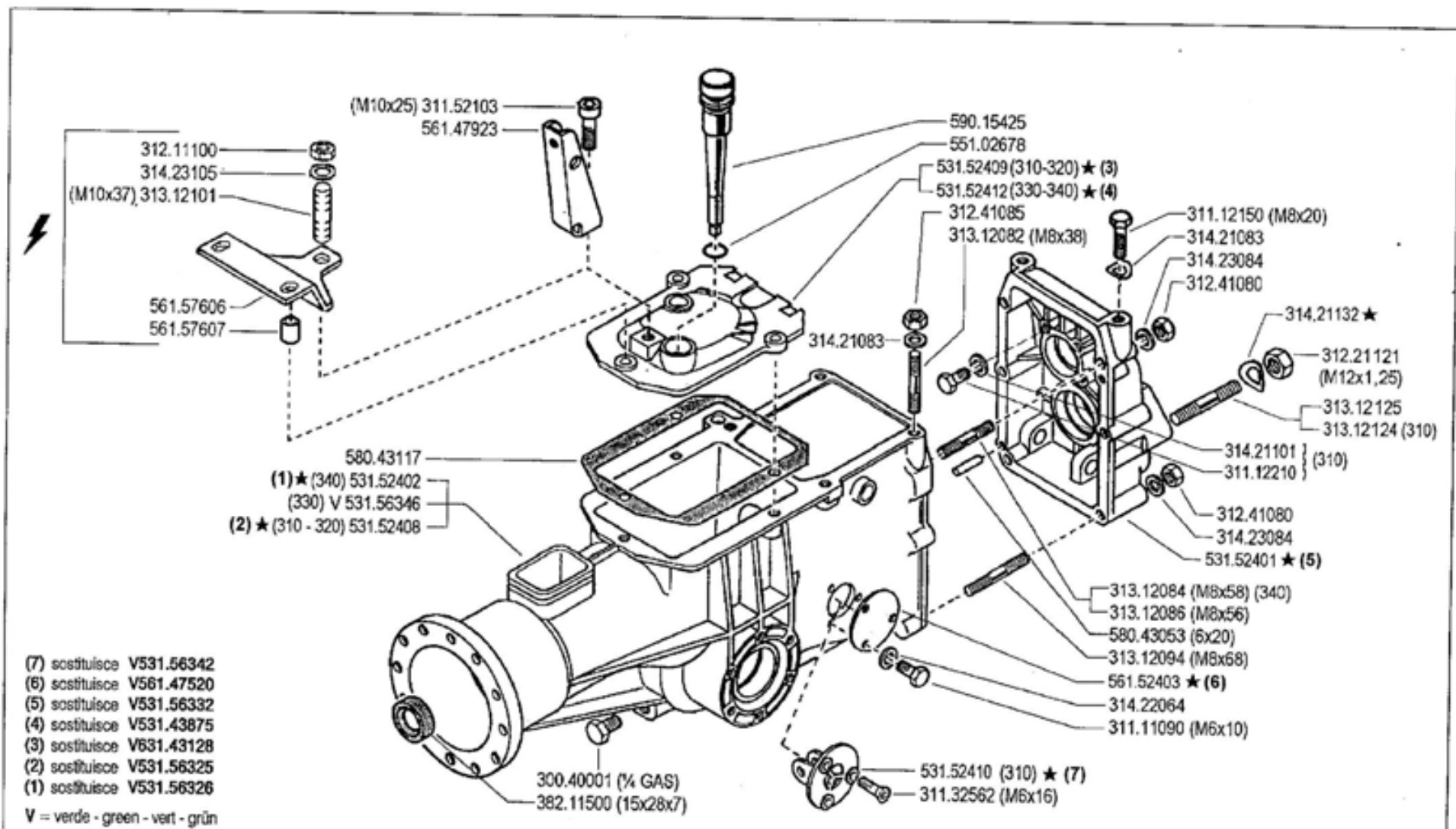

	<h1>300 serie 95</h1>	SCATOLA CAMBIO GEARBOX CAJA DE CAMBIO	BOITE DE VITESSES WECHSELGETRIEBE	DALLA MACCHINA DE LA MAQUINA FROM THE MACHINE AB DER MASCHINE	AGGIORNAMENTO	<h1>04</h1>	Rev. <h1>3</h1>
					REVISION		
					MISE A JOUR		
					APLAZAMIENTO		
				★N	ANPASSUNG	12/2002	

Pos.	Code	Q.ty	Description	Notes
53156332	53156332	0	REAR COVER	
53156342	53156342	0	GEAR SUPPORT	
53156346	53156346	0	BODY	
55102678	55102678	0	RUBBER RING	
56147520	56147520	0	COVER	
56147923	56147923	0	BRACKET	
56152403	56152403	0	COVER	
56157606	56157606	0	STOP	
56157607	56157607	0	SPACER	
58043053	58043053	0	CYLINDRICAL PLUG	
58043117	58043117	0	COVER GASKET	
59015425	59015425	0	PLUG	

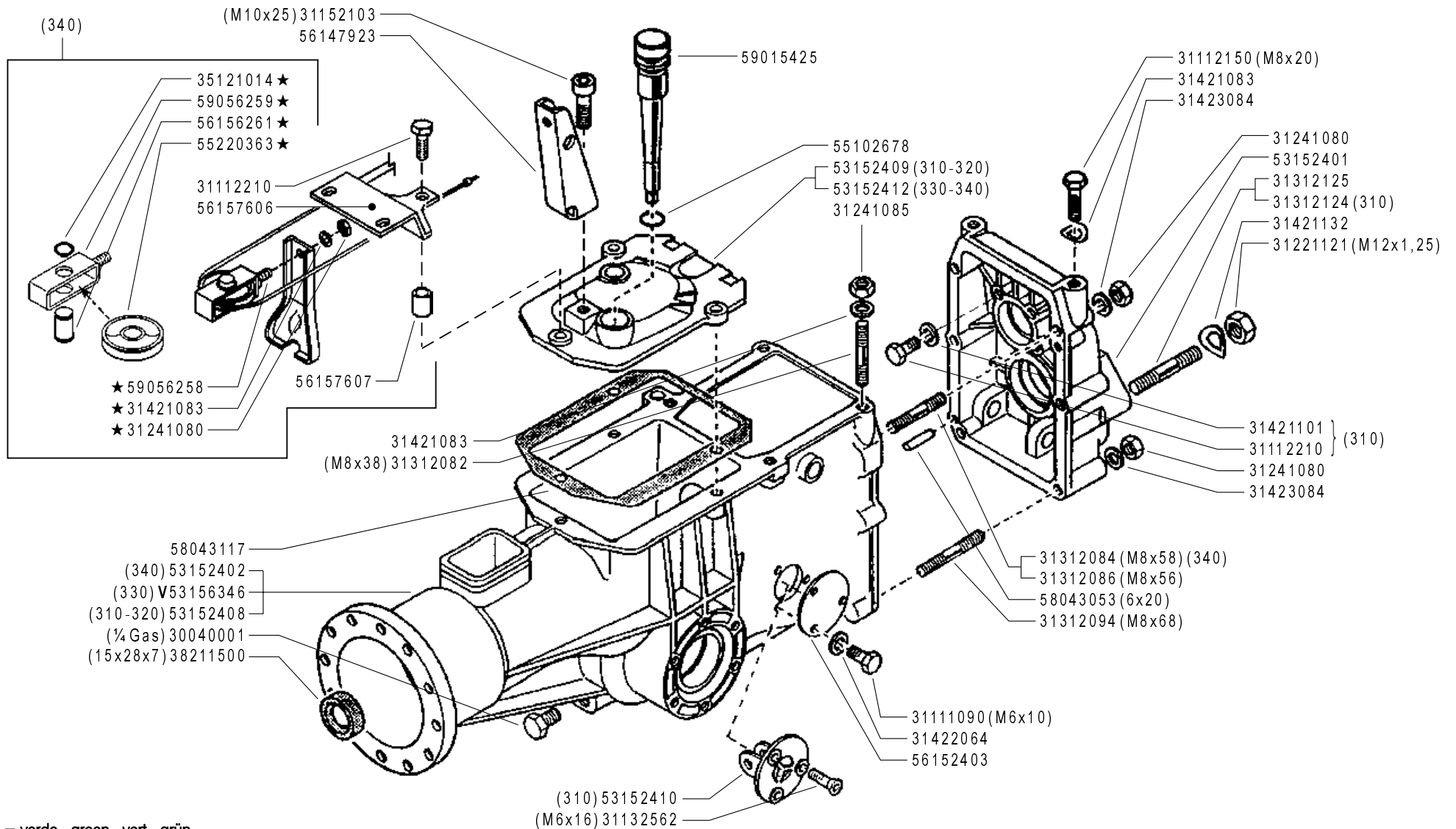

V = verde - green - vert - grün

FERRARI

300 serie 95

GEARBOX
CAJA DE CAMBIO

SCATOLA CAMBIO

BOITE DE VITESSES
WECHSELGETRIEBE

DALLA MACCHINA
DE LA MAQUINA
DE LA MACHINE
FROM THE MACHINE
AB DER MASCHINE

★ N.

749391 (340)

04

Rev.
4

02/2006

ZENNE

Pos.	Code	Q.ty	Description	Notes
30040001	30040001	1	PLUG	
31111090	31111090	1	SCREW TE M5X10 UNI 5739 8G	
31112150	31112150	1	SCREW TE M8X20 UNI 5739 8G	
31112210	31112210	1	SCREW TE M10X20 UNI 5739	
31132562	31132562	1	SCREW TSVEI M6X16 UNI 5933	
31152103	31152103	1	SCREW TCEI M10X25 UNI 5931	
31221121	31221121	1	NUT M12X1,25	
31241080	31241080	1	SELFLOCK NUT M8	
31241085	31241085	1	SELFLOCK NUT M8 6S	
31312082	31312082	1	STUD BOLT M8X38X14X20	
31312084	31312084	1	STUD BOLT M8X58X16X16	
31312086	31312086	1	STUD BOLT M8X56X20X14	
31312094	31312094	1	STUD BOLT M8X68X14X36	
31312124	31312124	1	STUD BOLT	
31312125	31312125	1	STUD BOLT	
31421083	31421083	1	WASHER	
31421101	31421101	1	WASHER	
31421132	31421132	1	WASHER 13X24X2,8	
31422064	31422064	1	SPRING WASHER 6,4	
31423084	31423084	1	SPRING WASHER 8,4	
35121014	35121014	1	SEEGER RING E 14 DIN 471	
38211500	38211500	1	OIL SEAL 15X28X7	
53152401	53152401	1	REAR COVER	
53152402	53152402	1	BODY	
53152408	53152408	1	BODY	
53152409	53152409	1	COVER	
53152410	53152410	1	GEAR SUPPORT	
53152412	53152412	1	COPERCHIO SCAT.CAMBIO DIFF.*V*	
53156346	53156346	1	BODY	
55102678	55102678	1	RUBBER RING	
55220363	55220363	1	PULLEY	
56147923	56147923	1	BRACKET	
56152403	56152403	1	COVER	
56156261	56156261	1	PIN	

SERIAL
START
749391

GEARBOX
Version: MC 340

CODE REV
004_4_25109

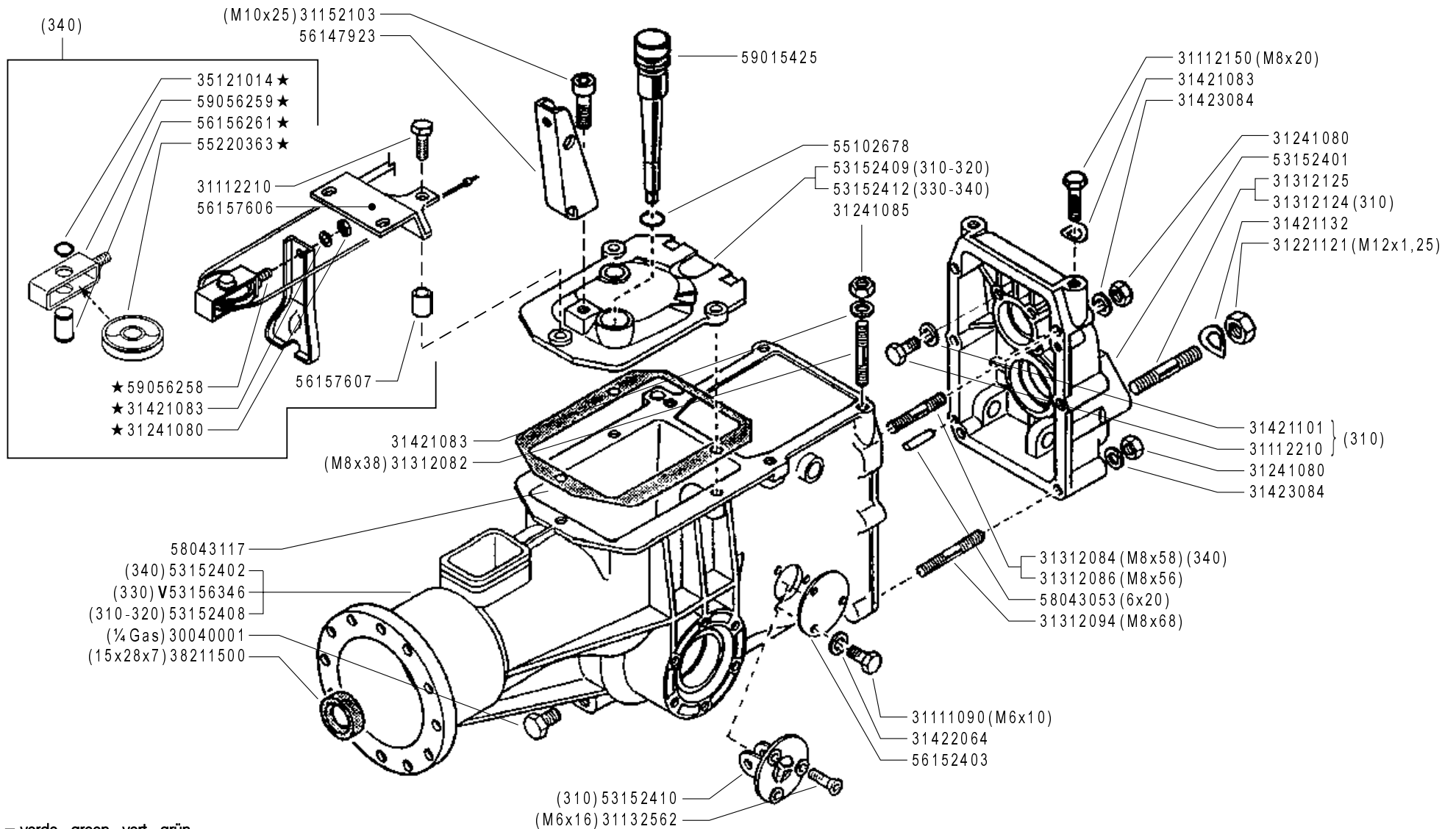

V = verde - green - vert - grün

SCATOLA CAMBIO

GEARBOX
CAJA DE CAMBIO

BOITE DE VITESSES
WECHSELGETRIEBE

DALLA MACCHINA
DE LA MAQUINA
DE LA MACHINE
FROM THE MACHINE
AB DER MASCHINE

★ N.

749391 (340)

04

Rev.
4

02/2006

ZENNE

FERRARI

300 serie 95

Pos.	Code	Q.ty	Description	Notes
56157606	56157606	1	STOP	
56157607	56157607	1	SPACER	
58043053	58043053	1	CYLINDRICAL PLUG	
58043117	58043117	1	COVER GASKET	
59015425	59015425	1	PLUG	
59056258	59056258	1	CLUTCH FORK	
59056259	59056259	1	CLUTCH FORK	

SERIAL
START
749391

GEARBOX
Version: MC 340

CODE REV
004_4_25109

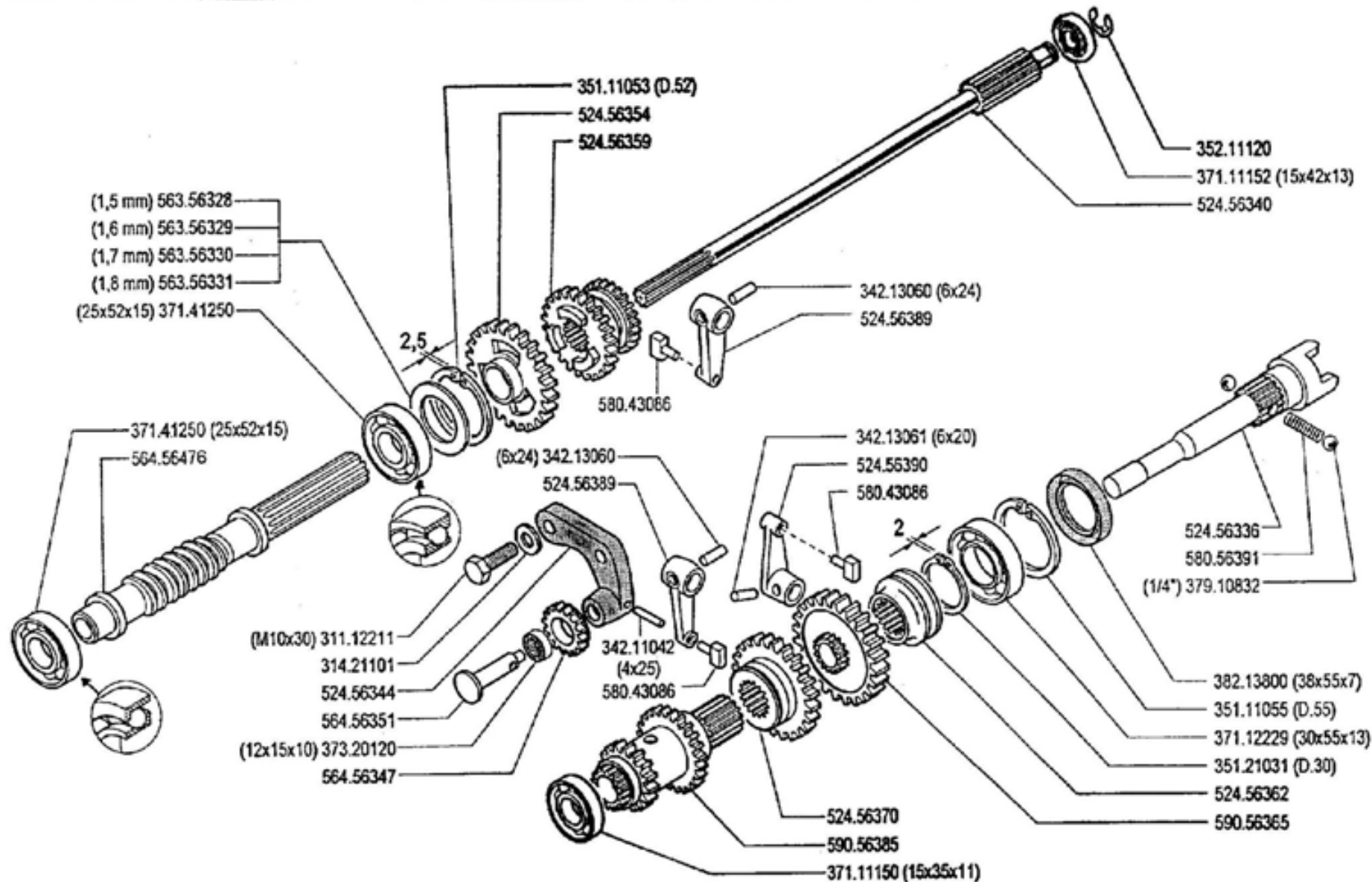

FERRARI

300 serie **95**

INGRANAGGI CAMBIO (340)

ENGRANAJES
ENGRANAGES

GEARS
ZÄHRÄDER

DALLA MACCHINA
DE LA MAQUINA
DE LA MACHINE
FROM THE MACHINE
AB DER MASCHINE

N.

06.00

01.06.1995

Pos.	Code	Q.ty	Description	Notes
31112211	31112211	0	SCREW TE M10X30 UNI 5739	
31421101	31421101	0	WASHER	
34211042	34211042	0	ROLL PIN	
34213060	34213060	0	ROLL PIN	
34213061	34213061	0	ROLL PIN	
35111053	35111053	0	SEEGER RING I 52 UNI 7438	
35111055	35111055	0	SEEGER RING I 55 DIN 472	
35121031	35121031	0	SEEGER RING E 30 UNI 7436	
35211120	35211120	0	SEEGER RING E 12 UNI 7434	
37111150	37111150	0	BEARING	
37111152	37111152	0	BEARING	
37112229	37112229	0	BEARING	
37141250	37141250	0	BEARING	
37320120	37320120	0	ROLLER CAGE 12X15/10	
37910832	37910832	0	BALL 1/4	
38213800	38213800	0	OIL SEAL 38X55X7	
52456336	52456336	0	PTO SHAFT	
52456340	52456340	0	SHAFT	
52456344	52456344	0	GEAR SUPPORT	
52456354	52456354	0	GEAR	
52456359	52456359	0	SLIDER	
52456362	52456362	0	COUPLING	
52456370	52456370	0	SLIDER	
52456389	52456389	0	LEVER	
52456390	52456390	0	LEVER	
56356328	56356328	0	ADJUSTING RING SP=1,5	
56356329	56356329	0	ADJUSTING RING SP=1,6	
56356330	56356330	0	ADJUSTING RING SP=1,7	
56356331	56356331	0	ADJUSTING RING SP=1,8	
56456347	56456347	0	GEAR	
56456351	56456351	0	GEAR PIN	
56456476	56456476	0	SCREW	
58043086	58043086	0	SHOE	
58056391	58056391	0	SPRING	

SERIAL

GEARS (340)

CODE REV

006_0_10884

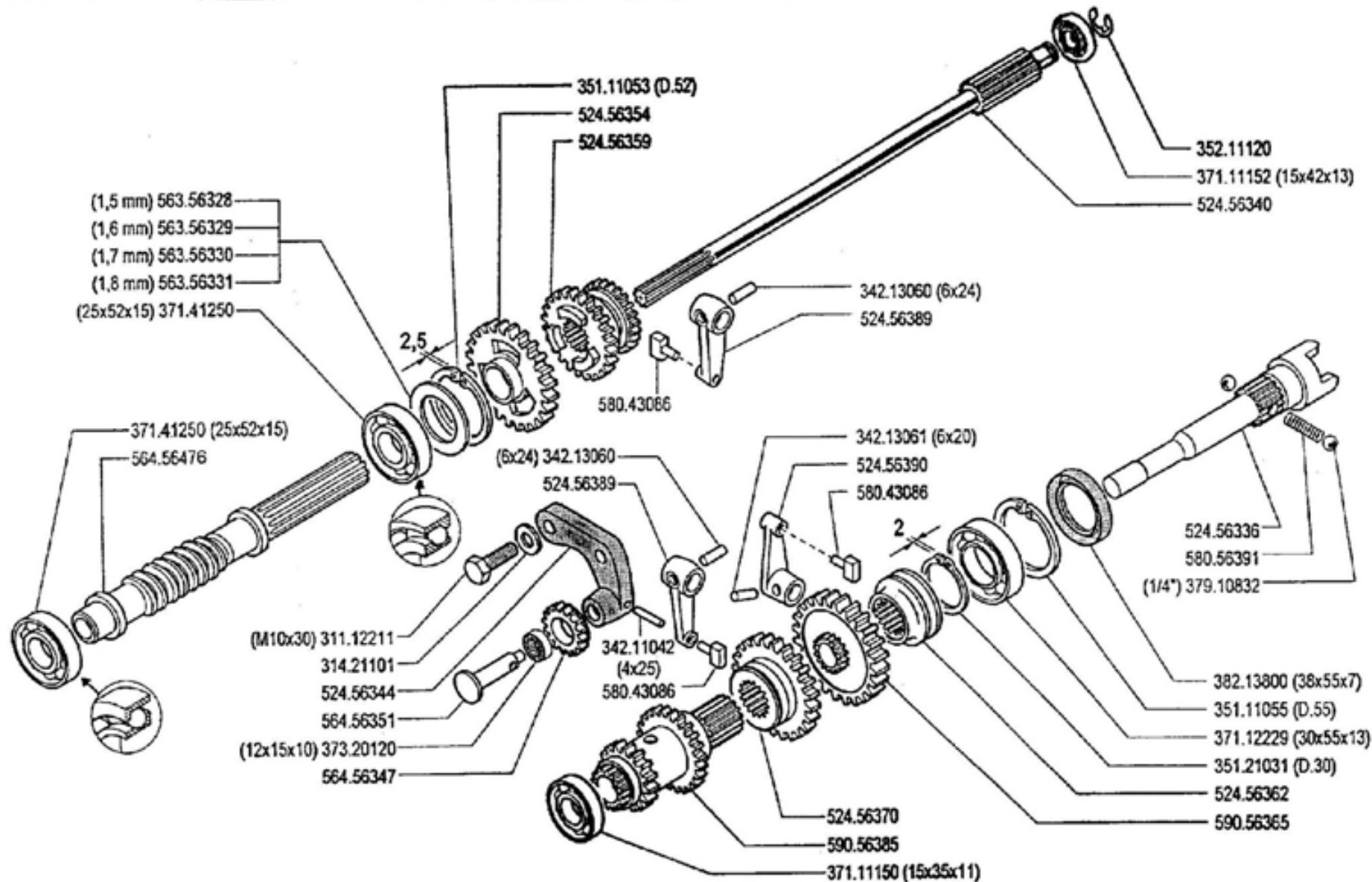

FERRARI

300 serie **95**

INGRANAGGI CAMBIO (340)

ENGRANAJES
ENGRANAGES

GEARS
ZÄHRÄDER

DALLA MACCHINA
DE LA MAQUINA
DE LA MACHINE
FROM THE MACHINE
AB DER MASCHINE

N.

06.00

01.06.1995

Pos.	Code	Q.ty	Description	Notes
59056365	59056365	0	PTO GEAR	
59056385	59056385	0	TRIPLE GEAR	

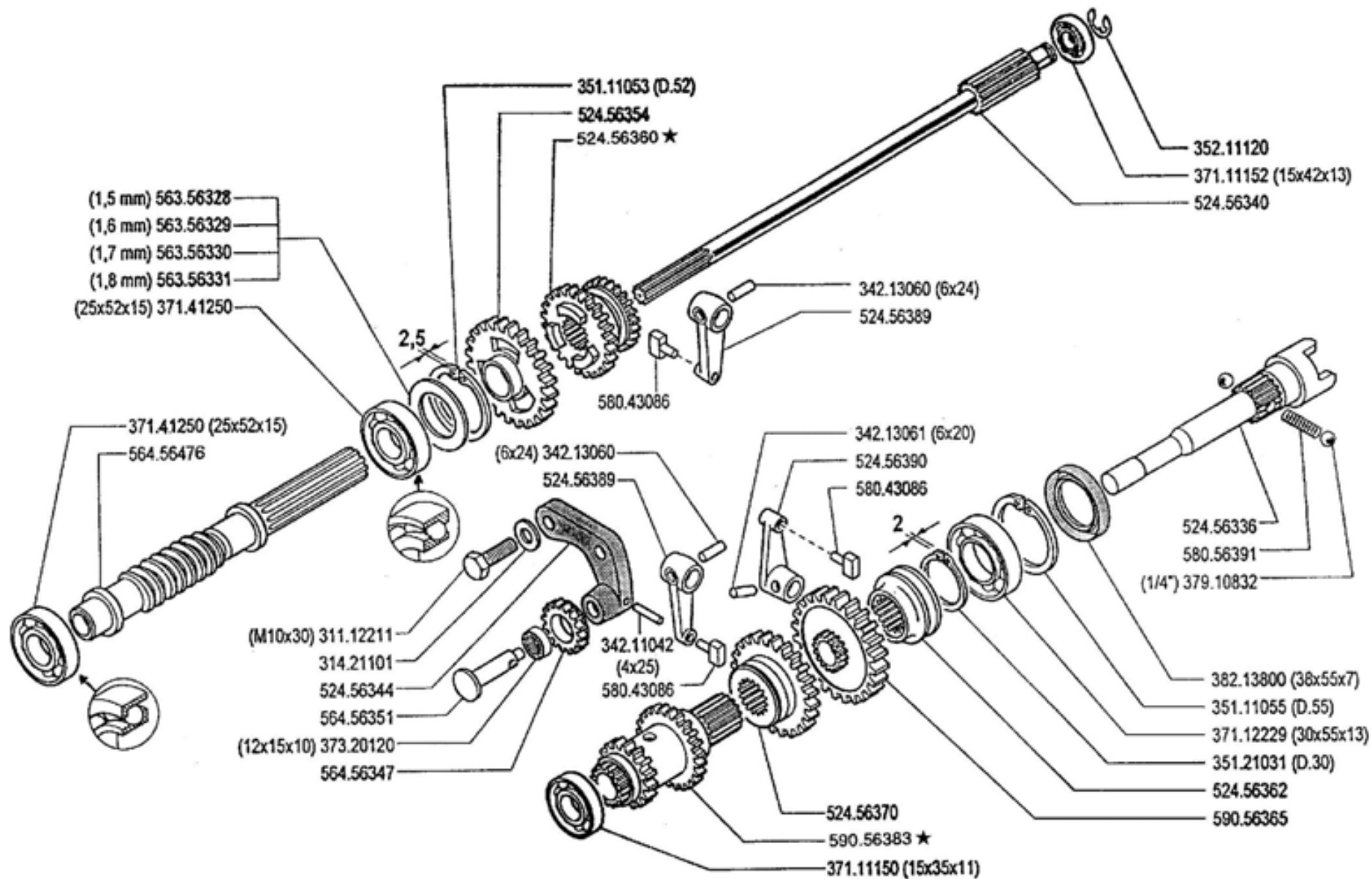

FERRARI

300 serie 95

GEARS
ENGRANAJES

INGRANAGGI CAMBIO (340)

ENGRANAGES
ZÄHRÄDER

DALLA MACCHINA
DE LA MAQUINA
DE LA MACHINE
FROM THE MACHINE
AB DER MASCHINE

★N.

3286

06 01

10/1996

27846

Pos.	Code	Q.ty	Description	Notes
31112211	31112211	0	SCREW TE M10X30 UNI 5739	
31421101	31421101	0	WASHER	
34211042	34211042	0	ROLL PIN	
34213060	34213060	0	ROLL PIN	
34213061	34213061	0	ROLL PIN	
35111053	35111053	0	SEEGER RING I 52 UNI 7438	
35111055	35111055	0	SEEGER RING I 55 DIN 472	
35121031	35121031	0	SEEGER RING E 30 UNI 7436	
35211120	35211120	0	SEEGER RING E 12 UNI 7434	
37111150	37111150	0	BEARING	
37111152	37111152	0	BEARING	
37112229	37112229	0	BEARING	
37141250	37141250	0	BEARING	
37320120	37320120	0	ROLLER CAGE 12X15/10	
37910832	37910832	0	BALL 1/4	
38213800	38213800	0	OIL SEAL 38X55X7	
52456336	52456336	0	PTO SHAFT	
52456340	52456340	0	SHAFT	
52456344	52456344	0	GEAR SUPPORT	
52456354	52456354	0	GEAR	
52456360	52456360	0	SLIDER	
52456362	52456362	0	COUPLING	
52456370	52456370	0	SLIDER	
52456389	52456389	0	LEVER	
52456390	52456390	0	LEVER	
56356328	56356328	0	ADJUSTING RING SP=1,5	
56356329	56356329	0	ADJUSTING RING SP=1,6	
56356330	56356330	0	ADJUSTING RING SP=1,7	
56356331	56356331	0	ADJUSTING RING SP=1,8	
56456347	56456347	0	GEAR	
56456351	56456351	0	GEAR PIN	
56456476	56456476	0	SCREW	
58043086	58043086	0	SHOE	
58056391	58056391	0	SPRING	

SERIAL
START
3286

GEARS (340)

CODE REV

006_1_10921

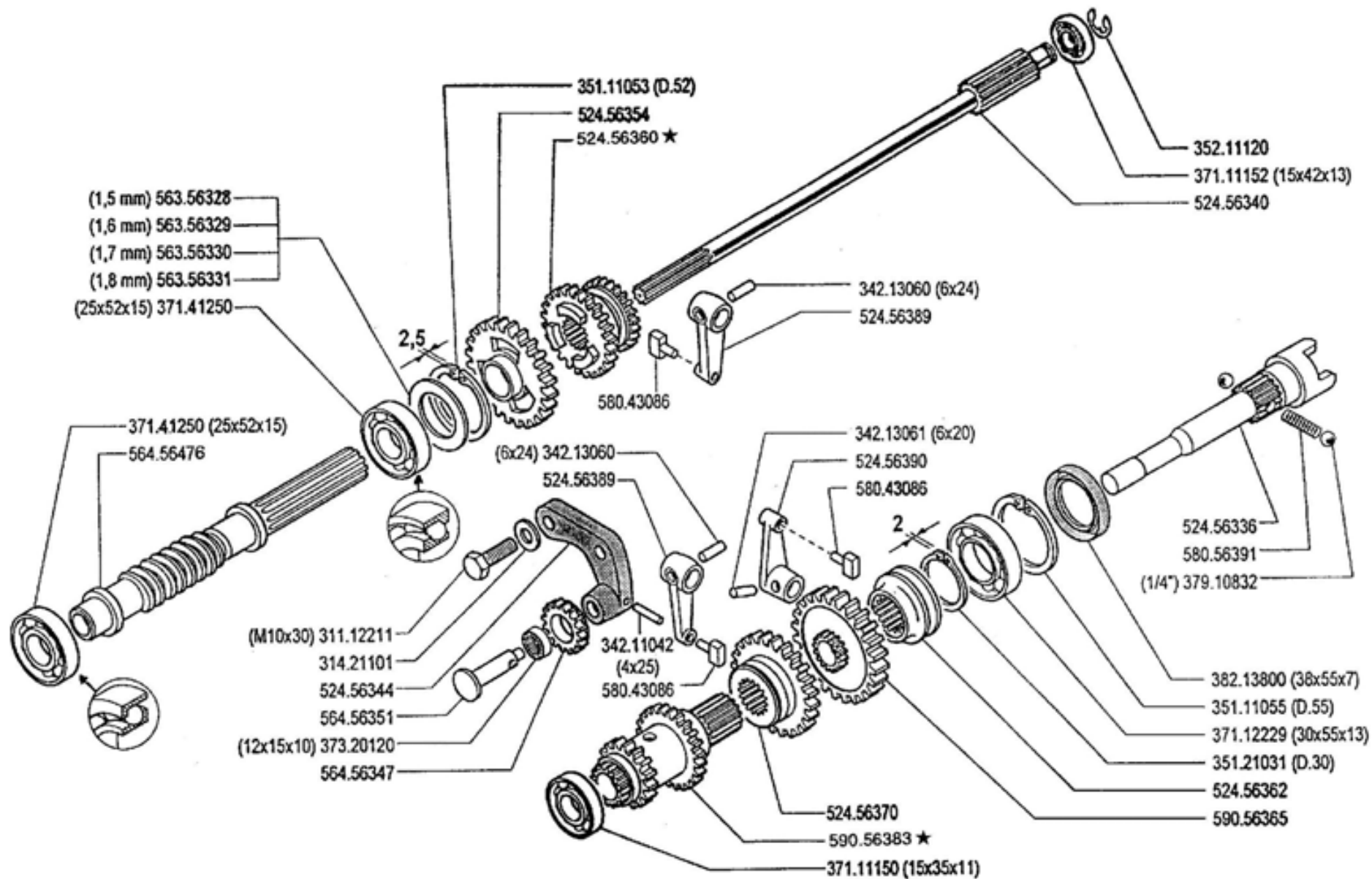

FERRARI

300 serie 95

GEARS
ENGRANAJES

INGRANAGGI CAMBIO (340)

ENGRANAGES
ZÄHRÄDER

DALLA MACCHINA
DE LA MAQUINA
DE LA MACHINE
FROM THE MACHINE
AB DER MASCHINE

★N.

3286

06 01

10/1996

27846

Pos.	Code	Q.ty	Description	Notes
59056365	59056365	0	PTO GEAR	
59056383	59056383	0	TRIPLE GEAR	

SERIAL
START
3286

GEARS (340)

CODE REV
006_1_10921

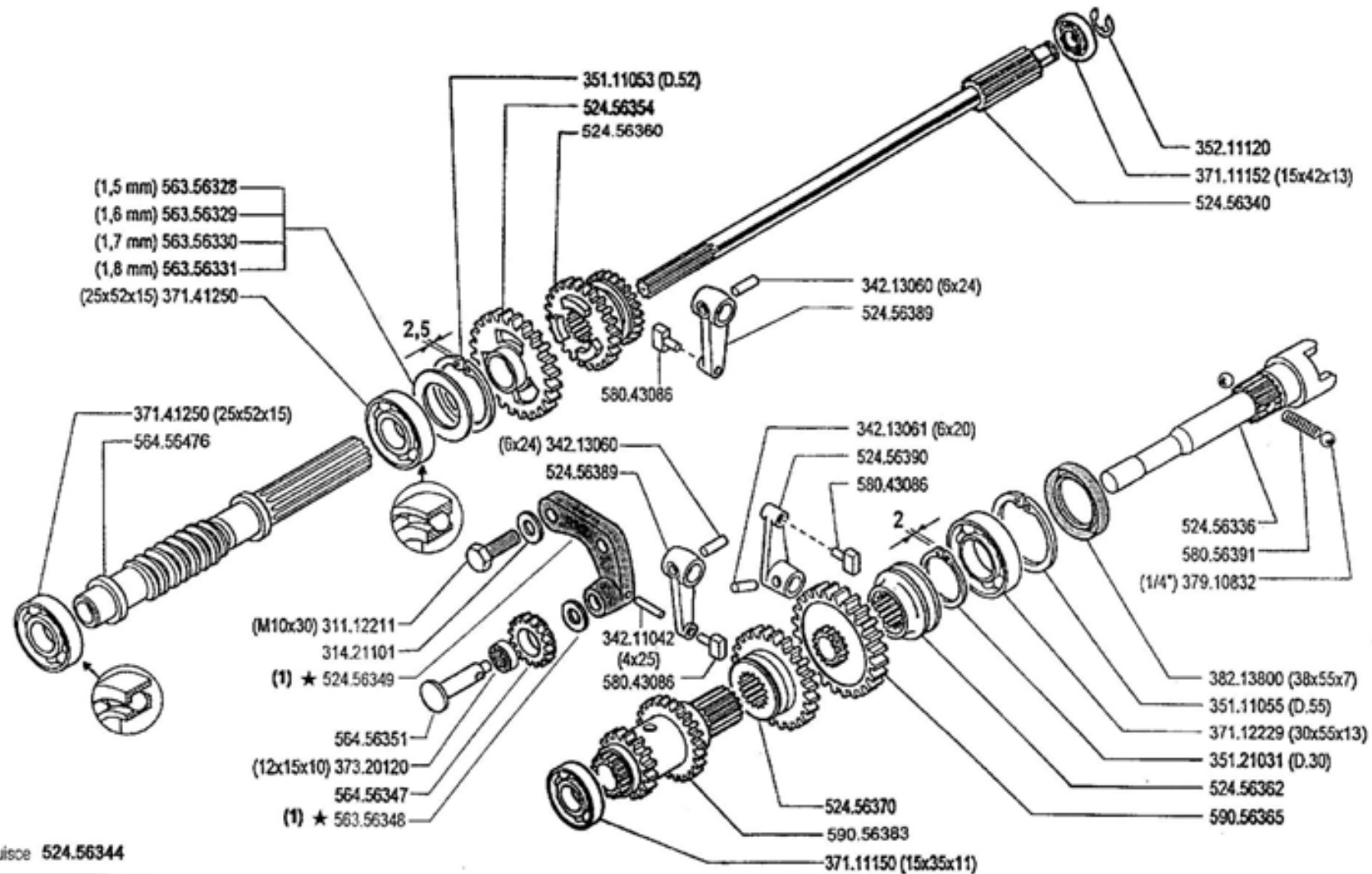

FERRARI

300 serie **95**

INGRANAGGI CAMBIO (340)

GEARS
ENGRANAJES

ENGRANAGES
ZÄHRÄDER

DALLA MACCHINA
DE LA MAQUINA
DE LA MACHINE
FROM THE MACHINE
AB DER MASCHINE

AGGIORNAMENTO
REVISION
MISE A JOUR
AFIJAZAMENTO
ANPASSUNG

06

Rev.
2

★N

9/2000

2000

Pos.	Code	Q.ty	Description	Notes
31112211	31112211	0	SCREW TE M10X30 UNI 5739	
31421101	31421101	0	WASHER	
34211042	34211042	0	ROLL PIN	
34213060	34213060	0	ROLL PIN	
34213061	34213061	0	ROLL PIN	
35111053	35111053	0	SEEGER RING I 52 UNI 7438	
35111055	35111055	0	SEEGER RING I 55 DIN 472	
35121031	35121031	0	SEEGER RING E 30 UNI 7436	
35211120	35211120	0	SEEGER RING E 12 UNI 7434	
37111150	37111150	0	BEARING	
37111152	37111152	0	BEARING	
37112229	37112229	0	BEARING	
37141250	37141250	0	BEARING	
37320120	37320120	0	ROLLER CAGE 12X15/10	
37910832	37910832	0	BALL 1/4	
38213800	38213800	0	OIL SEAL 38X55X7	
52456336	52456336	0	PTO SHAFT	
52456340	52456340	0	SHAFT	
52456349	52456349	0	GEAR SUPPORT	
52456354	52456354	0	GEAR	
52456360	52456360	0	SLIDER	
52456362	52456362	0	COUPLING	
52456370	52456370	0	SLIDER	
52456389	52456389	0	LEVER	
52456390	52456390	0	LEVER	
56356328	56356328	0	ADJUSTING RING SP=1,5	
56356329	56356329	0	ADJUSTING RING SP=1,6	
56356330	56356330	0	ADJUSTING RING SP=1,7	
56356331	56356331	0	ADJUSTING RING SP=1,8	
56356348	56356348	0	ADJUSTING RING	
56456347	56456347	0	GEAR	
56456351	56456351	0	GEAR PIN	
56456476	56456476	0	SCREW	
58043086	58043086	0	SHOE	

SERIAL

GEARS (340)

CODE REV

006_2_10958

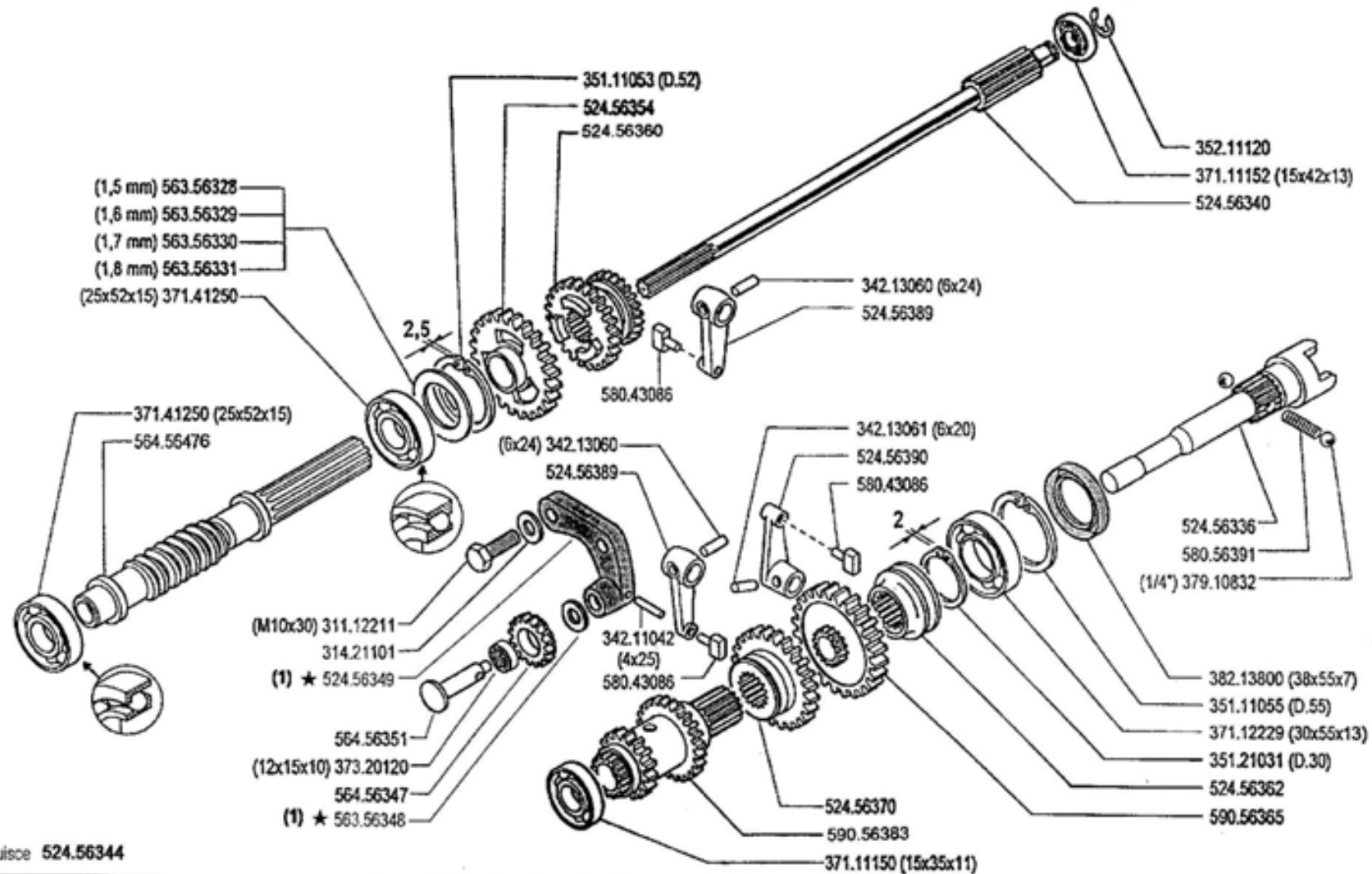

(1) sostituisce 524.56344

FERRARI

300 serie **95**

INGRANAGGI CAMBIO (340)

GEARS
ENGRANAJES

ENGRANAGES
ZÄHRÄDER

DALLA MACCHINA
DE LA MAQUINA
DE LA MACHINE
FROM THE MACHINE
AB DER MASCHINE

AGGIORNAMENTO

REVISION

MISE A JOUR

AFIJAZAMENTO

ANPASSUNG

06

Rev.
2

9/2000

★N

2000

Pos.	Code	Q.ty	Description	Notes
58056391	58056391	0	SPRING	
59056365	59056365	0	PTO GEAR	
59056383	59056383	0	TRIPLE GEAR	

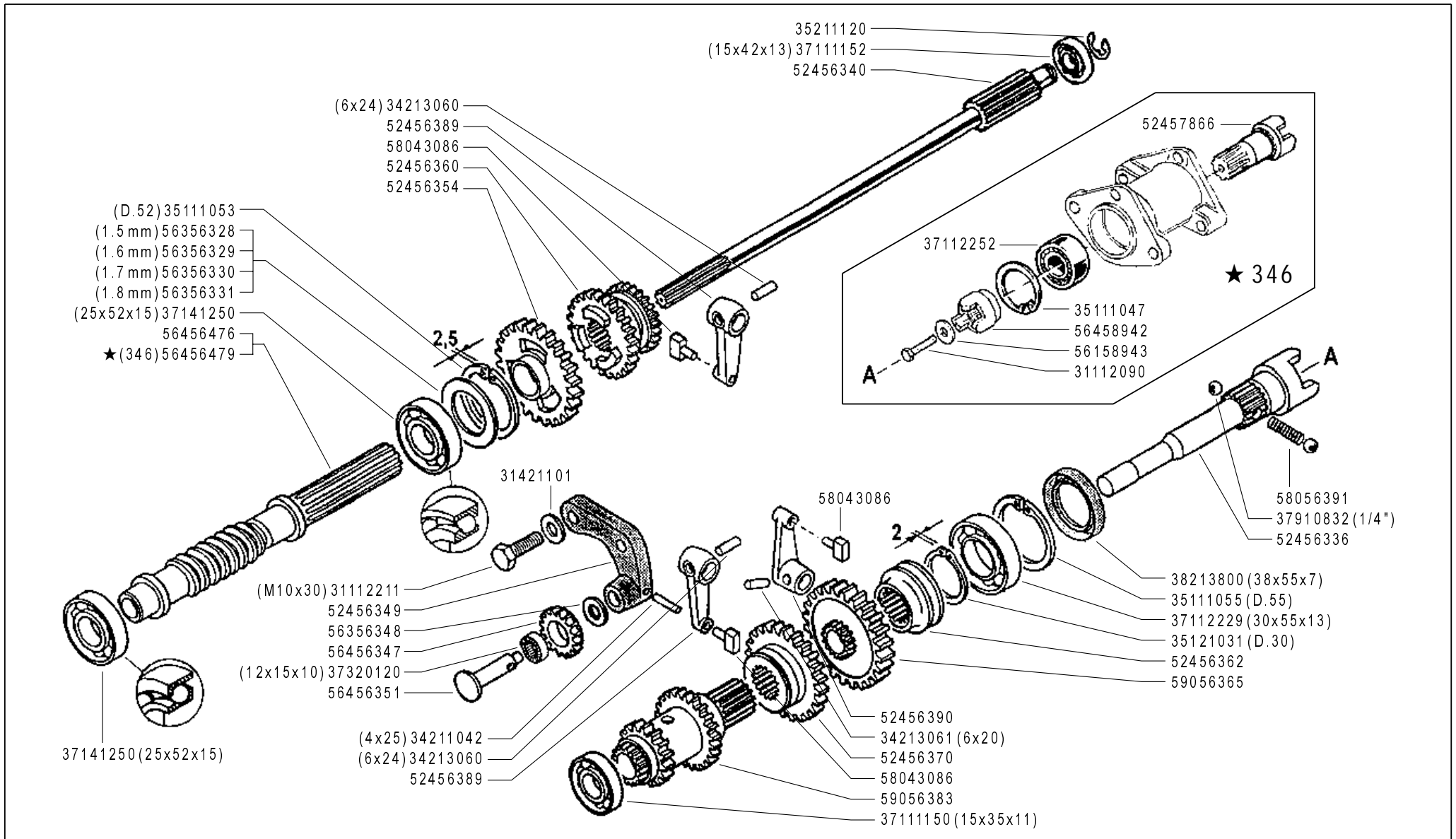

	300 serie 95	INGRANAGGI CAMBIO (340- ★ 346)		DALLA MACCHINA DE LA MAQUINA DE LA MACHINE FROM THE MACHINE AB DER MASCHINE	Rev.
		GEARS ENGRANAJES	ENGRANAGES ZAHNRÄDER		06 3
				★ N.	752002 (346)
				02/2006	

ZENNE

Pos.	Code	Q.ty	Description	Notes
00	35211120	1	SEEGER RING E 12 UNI 7434	
31112090	31112090	1	SCREW TE M6X16 UNI 5739 8G	
31112211	31112211	1	SCREW TE M10X30 UNI 5739	
31421101	31421101	1	WASHER	
34211042	34211042	1	ROLL PIN	
34213060	34213060	1	ROLL PIN	
34213061	34213061	1	ROLL PIN	
35111047	35111047	1	SEEGER RING I 47 DIN 472	
35111053	35111053	1	SEEGER RING I 52 UNI 7438	
35111055	35111055	1	SEEGER RING I 55 DIN 472	
35121031	35121031	1	SEEGER RING E 30 UNI 7436	
37111150	37111150	1	BEARING	
37111152	37111152	1	BEARING	
37112229	37112229	1	BEARING	
37112252	37112252	1	BEARING	
37141250	37141250	1	BEARING	
37320120	37320120	1	ROLLER CAGE 12X15/10	
37910832	37910832	1	BALL 1/4	
38213800	38213800	1	OIL SEAL 38X55X7	
52456336	52456336	1	PTO SHAFT	
52456340	52456340	1	SHAFT	
52456349	52456349	1	GEAR SUPPORT	
52456354	52456354	1	GEAR	
52456360	52456360	1	SLIDER	
52456362	52456362	1	COUPLING	
52456370	52456370	1	SLIDER	
52456389	52456389	1	LEVER	
52456390	52456390	1	LEVER	
52457866	52457866	1	SHAFT	
56158943	56158943	1	WASHER 7,0x25/2	
56356328	56356328	1	ADJUSTING RING SP=1,5	
56356329	56356329	1	ADJUSTING RING SP=1,6	
56356330	56356330	1	ADJUSTING RING SP=1,7	
56356331	56356331	1	ADJUSTING RING SP=1,8	

SERIAL
START
752002

GEARS (340 - 346)
Version: MC 340, MC 346

CODE REV
006_3_25213

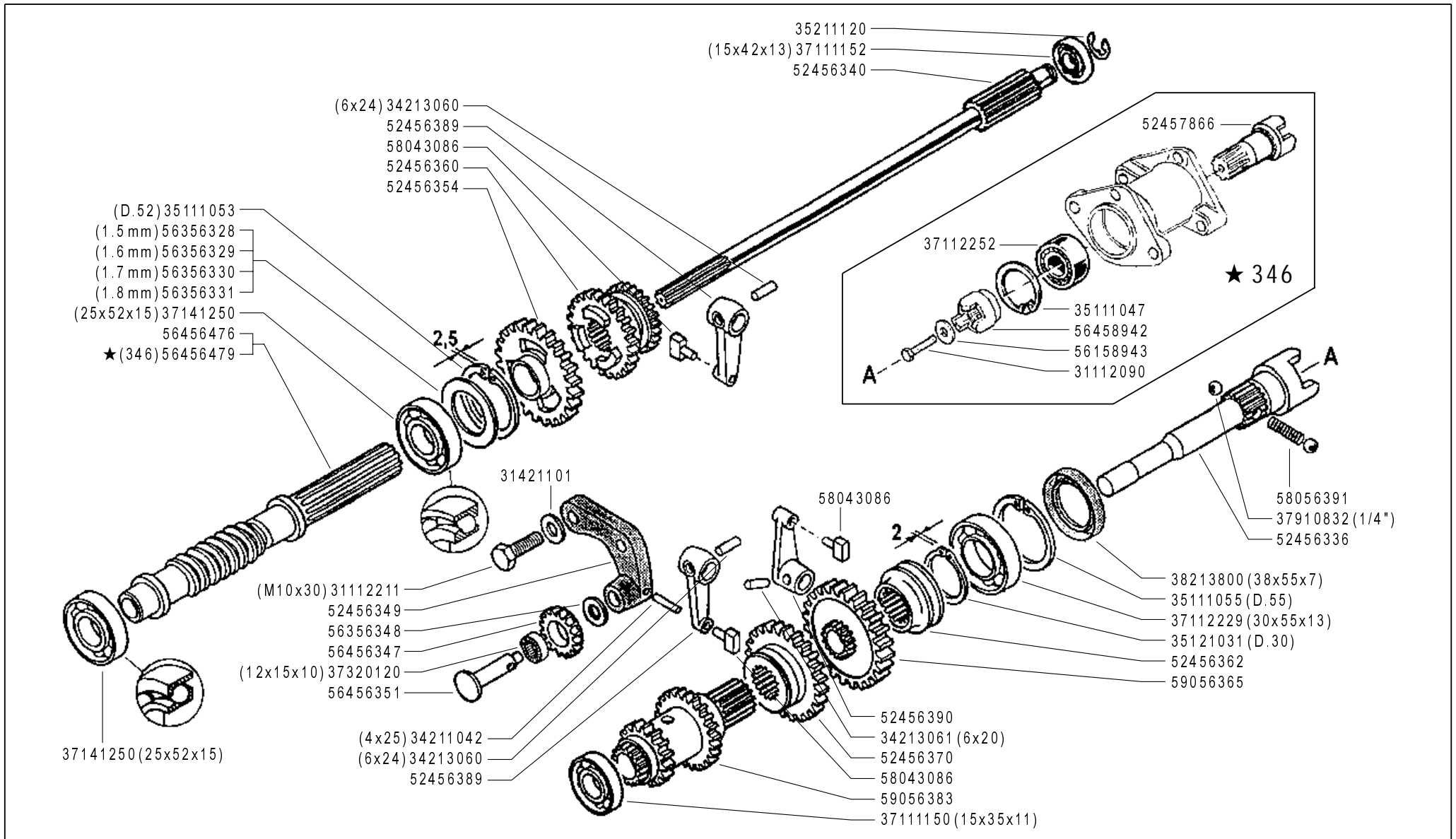

	300 serie 95	INGRANAGGI CAMBIO (340- ★ 346)		DALLA MACCHINA DE LA MAQUINA DE LA MACHINE FROM THE MACHINE AB DER MASCHINE	Rev.
		GEARS ENGRANAJES	ENGRANAGES ZAHNRÄDER		06
				★ N.	752002 (346)
				02/2006	

ZENNE

Pos.	Code	Q.ty	Description	Notes
56356348	56356348	1	ADJUSTING RING	
56456347	56456347	1	GEAR	
56456351	56456351	1	GEAR PIN	
56456476	56456476	1	SCREW	
56456479	56456479	1	SCREW	
56458942	56458942	1	COUPLING	
58043086	58043086	1	SHOE	
58056391	58056391	1	SPRING	
59056365	59056365	1	PTO GEAR	
59056383	59056383	1	TRIPLE GEAR	

SERIAL
START
752002

GEARS (340 - 346)
Version: MC 340, MC 346

CODE REV
006_3_25213

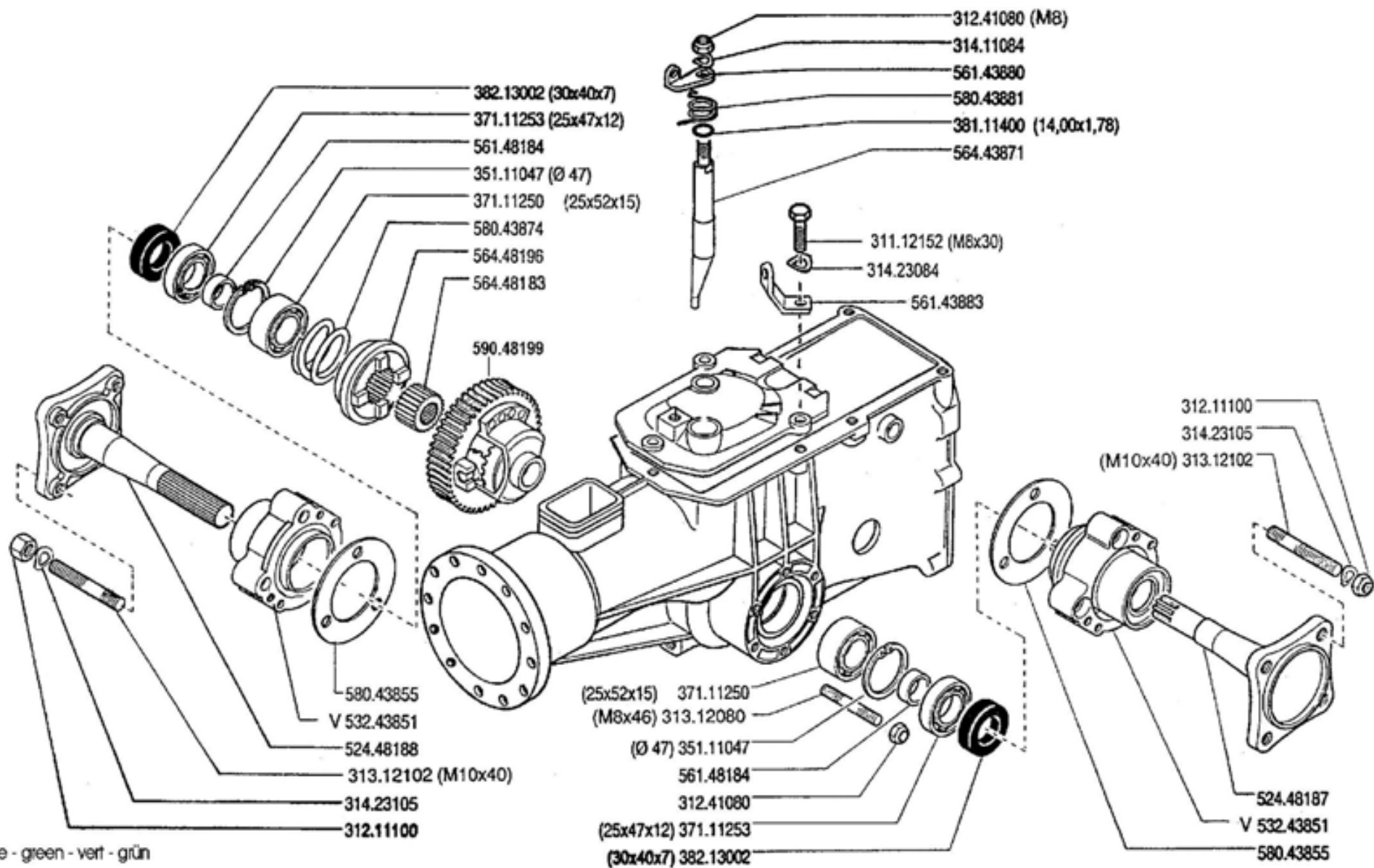

V = verde - green - vert - grün

FERRARI

300 serie 95

DIFFERENZIALE (340)

DIFFERENTIAL
DIFFERENCIAL

DIFFERENTIEL
DIFFERENTIAL

DALLA MACCHINA
DE LA MAGINA
DE LA MACHINE
FROM THE MACHINE
AB DER MASCHINE

N.

09 00

6/1995

Wid

ZENIT

Pos.	Code	Q.ty	Description	Notes
31112152	31112152	0	SCREW TE M8X30 UNI 5739 8G	
31211100	31211100	0	NUT M10	
31241080	31241080	0	SELFLOCK NUT M8	
31312080	31312080	0	STUD BOLT M8X46X20X12	
31312102	31312102	0	STUD BOLT M10X40X24X12	
31411084	31411084	0	WASHER 8,4x17	
31423084	31423084	0	SPRING WASHER 8,4	
31423105	31423105	0	SPRING WASHER 10,5	
35111047	35111047	0	SEEGER RING I 47 DIN 472	
37111250	37111250	0	BEARING	
37111253	37111253	0	BEARING	
38111400	38111400	0	O-RING 2056 (14,00X1,78)	
38213002	38213002	0	OIL SEAL 30X40X7	
52448187	52448187	0	AXLE SHAFT	
52448188	52448188	0	AXLE SHAFT	
53243851	53243851	0	HUB	
56143880	56143880	0	SMALL LEVER	
56143883	56143883	0	STOP	
56148184	56148184	0	RING	
56443871	56443871	0	ROD	
56448183	56448183	0	SPACER	
56448196	56448196	0	COUPLING	
58043855	58043855	0	GASKET	
58043874	58043874	0	SPRING	
58043881	58043881	0	SPRING	
59048199	59048199	0	DIFFERENTIAL GEAR	

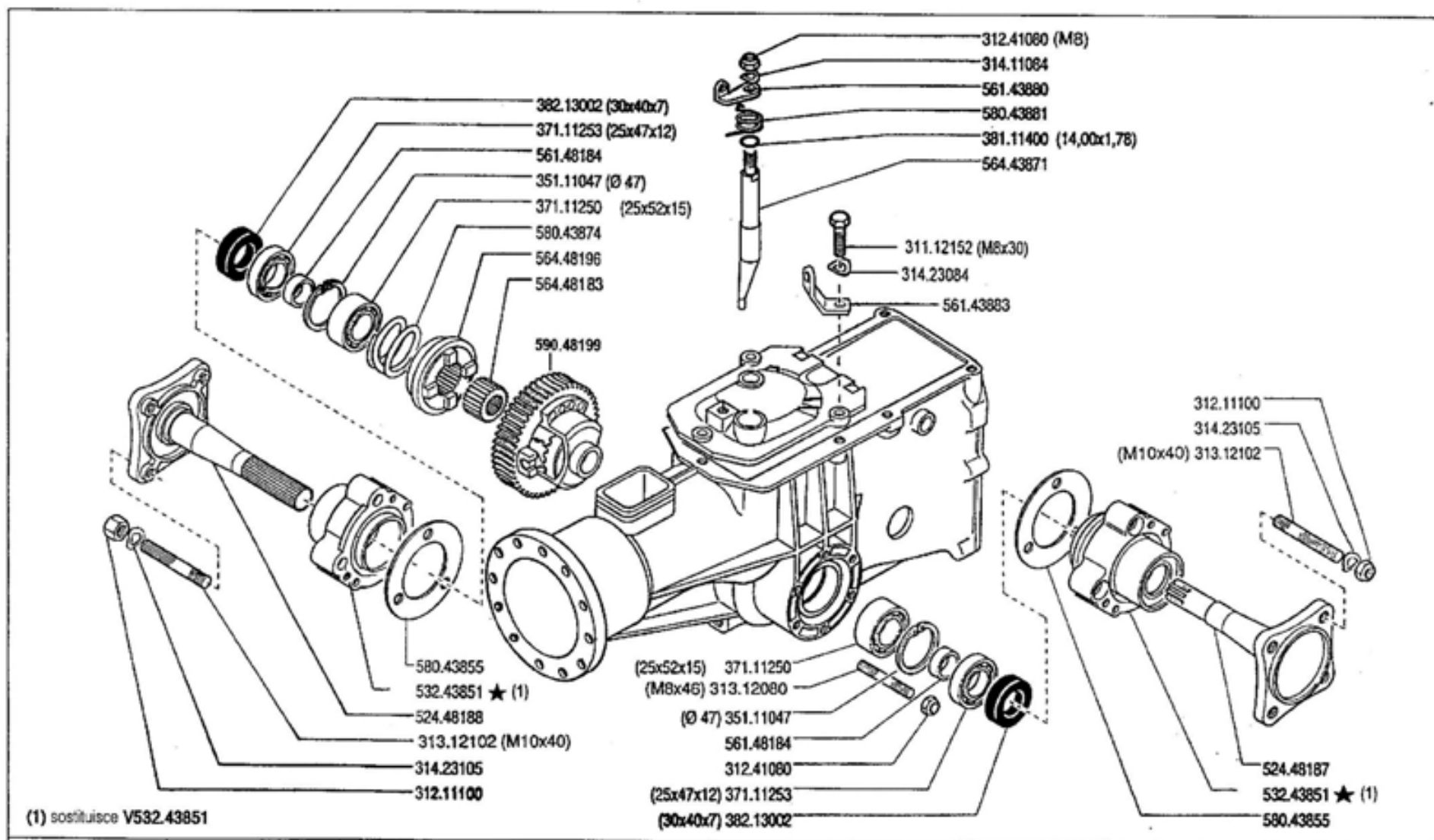

FERRARI

300 serie **95**

DIFFERENZIALE (340)

DIFFERENTIAL
DIFFERENCIAL

DIFFERENTIEL
DIFFERENTIAL

DALLA MACCHINA
DE LA MAQUINA
DE LA MACHINE
FROM THE MACHINE
AB DER MASCHINE

AGGIORNAMENTO

REVISION

MISE A JOUR

AFLAZAMENTO

ANPASSUNG

09

Rev.
1

6/2000

★N

20/000

Pos.	Code	Q.ty	Description	Notes
31112152	31112152	0	SCREW TE M8X30 UNI 5739 8G	
31211100	31211100	0	NUT M10	
31241080	31241080	0	SELFLOCK NUT M8	
31312080	31312080	0	STUD BOLT M8X46X20X12	
31312102	31312102	0	STUD BOLT M10X40X24X12	
31411084	31411084	0	WASHER 8,4x17	
31423084	31423084	0	SPRING WASHER 8,4	
31423105	31423105	0	SPRING WASHER 10,5	
35111047	35111047	0	SEEGER RING I 47 DIN 472	
37111250	37111250	0	BEARING	
37111253	37111253	0	BEARING	
38111400	38111400	0	O-RING 2056 (14,00X1,78)	
38213002	38213002	0	OIL SEAL 30X40X7	
52448187	52448187	0	AXLE SHAFT	
52448188	52448188	0	AXLE SHAFT	
53243851	53243851	0	HUB	
56143880	56143880	0	SMALL LEVER	
56143883	56143883	0	STOP	
56148184	56148184	0	RING	
56443871	56443871	0	ROD	
56448183	56448183	0	SPACER	
56448196	56448196	0	COUPLING	
58043855	58043855	0	GASKET	
58043874	58043874	0	SPRING	
58043881	58043881	0	SPRING	
59048199	59048199	0	DIFFERENTIAL GEAR	

Pos.	Code	Q.ty	Description	Notes
31112148	31112148	0	SCREW TE M8X18 UNI 5739 8G	
31112149	31112149	0	SCREW TE M8X12 UNI 5739 8G	
31215100	31215100	0	NUT M10	
31241080	31241080	0	SELFLOCK NUT M8	
31241101	31241101	0	SELFLOCK NUT M10	
31411084	31411084	0	WASHER 8,4x17	
31411104	31411104	0	WASHER 10,5x18	
31421083	31421083	0	WASHER	
31423084	31423084	0	SPRING WASHER 8,4	
31423105	31423105	0	SPRING WASHER 10,5	
34110028	34110028	0	SPLIT PIN	
34213020	34213020	0	ROLL PIN	
34213022	34213022	0	ROLL PIN	
34213024	34213024	0	ROLL PIN	
37911532	37911532	0	BALL 15/32	
38112817	38112817	0	O-RING 4112 (28,17X3,53)	
38211400	38211400	0	OIL SEAL 14X22X4	
52357250	52357250	0	PIN	
55142076	55142076	0	KNOB	
55247644	55247644	0	JOINT	
55248379	55248379	0	JOINT	
55257255	55257255	0	STOP	
56147560	56147560	0	STOP	
56147574	56147574	0	SMALL BLOCK	
56147646	56147646	0	PULL ROD	
56147648	56147648	0	PULL ROD	
56147664	56147664	0	GEAR	
56147672	56147672	0	GUIDE PIN	
56147703	56147703	0	GEAR	
56157239	56157239	0	GEAR SELECTOR	
56157267	56157267	0	PTO LEVER	
56157271	56157271	0	COMMAND LEVER	
56157303	56157303	0	SPACER	
56347700	56347700	0	FERRULE	

SERIAL

STEERING COLUMN AND CONTROLS (340)

CODE REV

011_0_11257

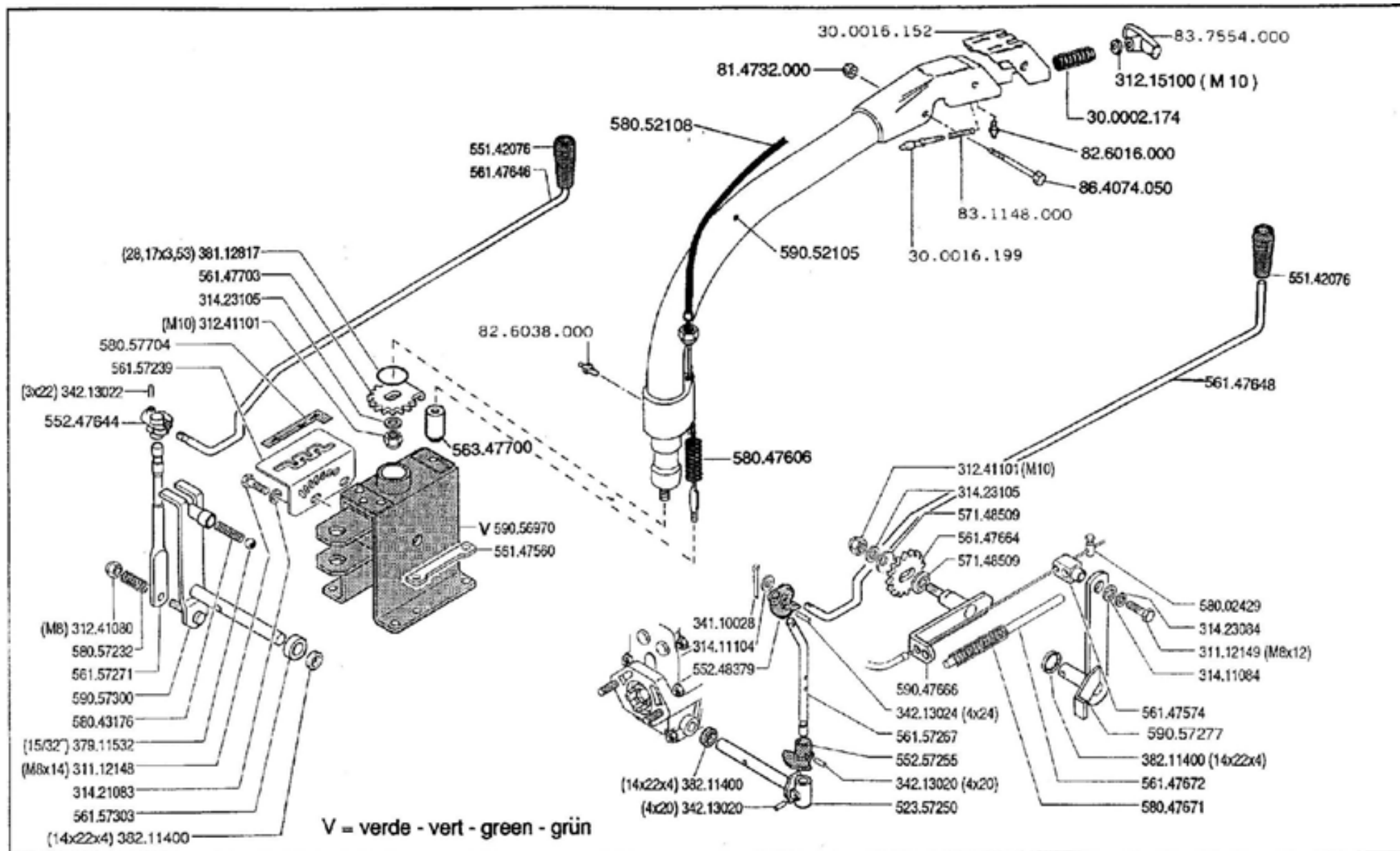

FERRARI

300 serie **95**

COLUMN
PLANTON

PIANTONE (340)

STEERING COLUMN
LENKSÄULE

DALLA MACCHINA
DE LA MAQUINA
DE LA MACHINE
FROM THE MACHINE
AB DER MASCHINE

N.

11.00

01.06.1995

Pos.	Code	Q.ty	Description	Notes
57148509	57148509	0	BOTTOM	
58002429	58002429	0	CLAMPING SCREW	
58043176	58043176	0	SPRING	
58047606	58047606	0	SPRING	
58047671	58047671	0	SPRING	
58052108	58052108	0	CABLE	
58057232	58057232	0	SPRING	
58057704	58057704	0	DECAL	
59047666	59047666	0	COMMAND LEVER	
59052105	59052105	0	PLOUGHTAIL	
59056970	59056970	0	SUPPORT	
59057277	59057277	0	LEVER	
59057300	59057300	0	GEAR LEVER	
F0300002	F0300002174	0	BELLOWS	
F0300016	F0300016152	0	SUMP	
F0300016	F0300016199	0	STAKE	
F0814732	F0814732000	0	NUT M12X1,5	
F0826016	F0826016000	0	LUBRICATOR M6 UNI 7663A	
F0826038	F0826038000	0	LUBRICATOR M8x1,25 UNI 7663A	
F0831148	F0831148000	0	SPRING DM.12,5X45	
F0837554	F0837554000	0	GRIP	
F0864074	F0864074050	0	SPECIAL SCREW M12X1,5	

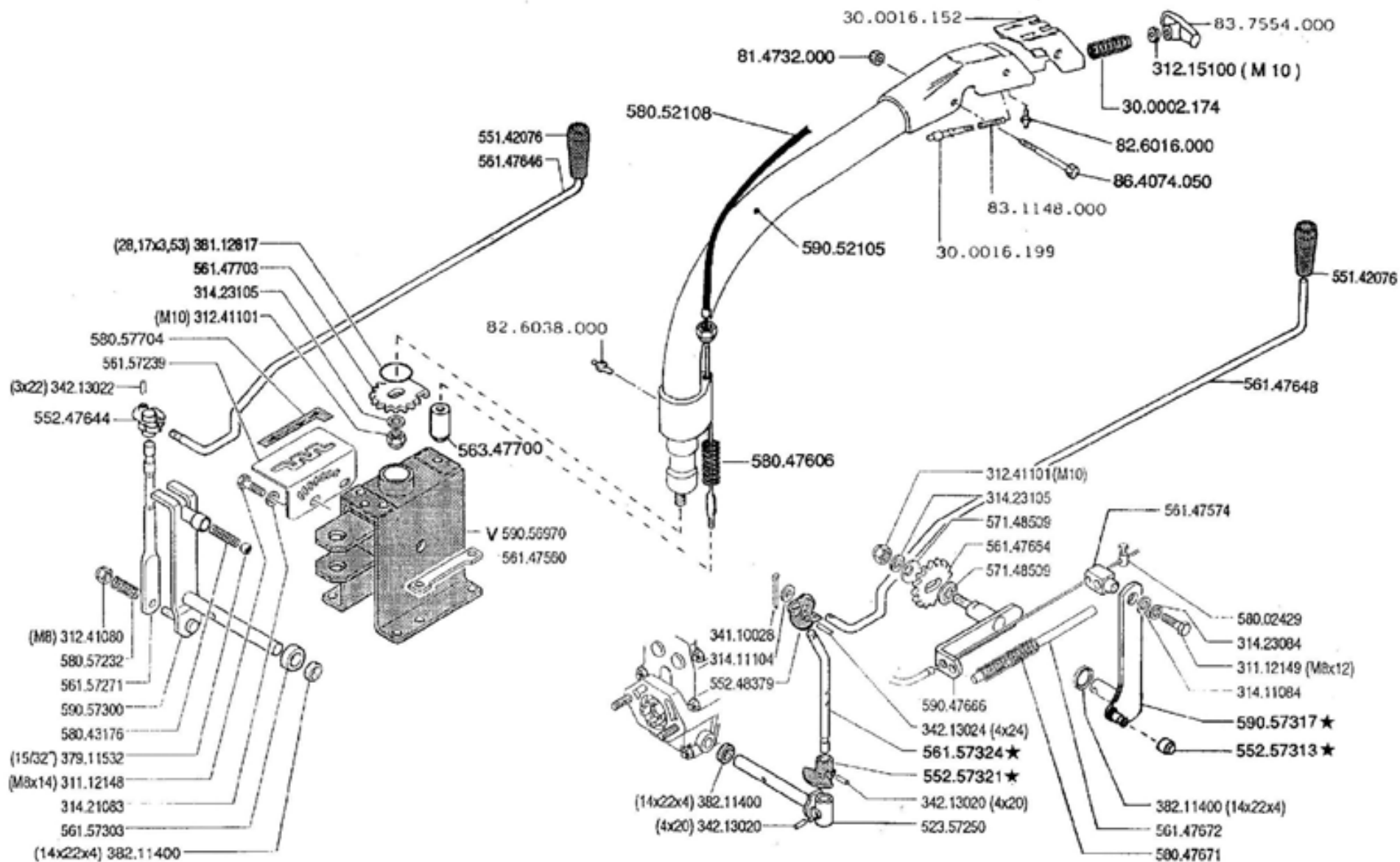

V = verde - green - vert - grün

FERRARI

300 serie 95

STEERING COLUMN
COLUMNA

PIANTONE (340)

PLANTON
LENKSÄULE

DALLA MACCHINA
DE LA MACQUINA
DE LA MACHINE
FROM THE MACHINE
AB DER MASCHINE

★N.

3760

11 01

11/1996

ZENIT

Pos.	Code	Q.ty	Description	Notes
31112148	31112148	0	SCREW TE M8X18 UNI 5739 8G	
31112149	31112149	0	SCREW TE M8X12 UNI 5739 8G	
31215100	31215100	0	NUT M10	
31241080	31241080	0	SELFLOCK NUT M8	
31241101	31241101	0	SELFLOCK NUT M10	
31411084	31411084	0	WASHER 8,4x17	
31411104	31411104	0	WASHER 10,5x18	
31421083	31421083	0	WASHER	
31423084	31423084	0	SPRING WASHER 8,4	
31423105	31423105	0	SPRING WASHER 10,5	
34110028	34110028	0	SPLIT PIN	
34213020	34213020	0	ROLL PIN	
34213022	34213022	0	ROLL PIN	
34213024	34213024	0	ROLL PIN	
37911532	37911532	0	BALL 15/32	
38112817	38112817	0	O-RING 4112 (28,17X3,53)	
38211400	38211400	0	OIL SEAL 14X22X4	
52357250	52357250	0	PIN	
55142076	55142076	0	KNOB	
55247644	55247644	0	JOINT	
55248379	55248379	0	JOINT	
55257313	55257313	0	ROLLER	
55257321	55257321	0	STOP	
56147560	56147560	0	STOP	
56147574	56147574	0	SMALL BLOCK	
56147646	56147646	0	PULL ROD	
56147648	56147648	0	PULL ROD	
56147664	56147664	0	GEAR	
56147672	56147672	0	GUIDE PIN	
56147703	56147703	0	GEAR	
56157239	56157239	0	GEAR SELECTOR	
56157271	56157271	0	COMMAND LEVER	
56157303	56157303	0	SPACER	
56157324	56157324	0	PTO LEVER	

SERIAL
START
3760

STEERING COLUMN AND CONTROLS (340)

CODE REV
011_1_11314

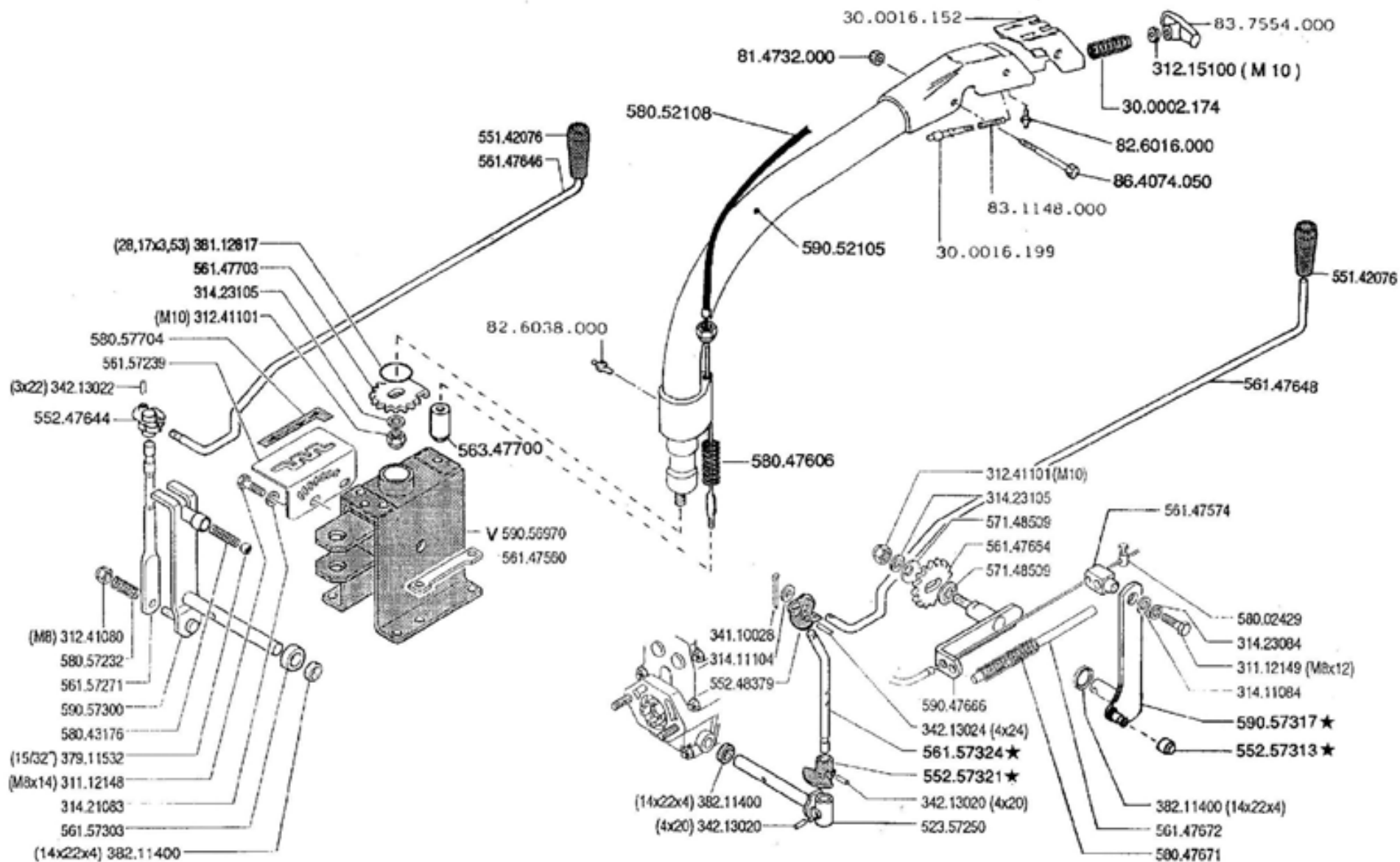

V = verde - green - vert - grün

FERRARI

300 serie 95

STEERING COLUMN
COLUMNA

PIANTONE (340)

PLANTON
LENKSÄULE

DALLA MACCHINA
DE LA MACQUINA
DE LA MACHINE
FROM THE MACHINE
AB DER MASCHINE

★N.

3760

11 01

11/1996

ZENIT

Pos.	Code	Q.ty	Description	Notes
56347700	56347700	0	FERRULE	
57148509	57148509	0	BOTTOM	
58002429	58002429	0	CLAMPING SCREW	
58043176	58043176	0	SPRING	
58047606	58047606	0	SPRING	
58047671	58047671	0	SPRING	
58052108	58052108	0	CABLE	
58057232	58057232	0	SPRING	
58057704	58057704	0	DECAL	
59047666	59047666	0	COMMAND LEVER	
59052105	59052105	0	PLOUGHTAIL	
59056970	59056970	0	SUPPORT	
59057300	59057300	0	GEAR LEVER	
59057317	59057317	0	LEVER	
F0300002	F0300002174	0	BELLOWS	
F0300016	F0300016152	0	SUMP	
F0300016	F0300016199	0	STAKE	
F0814732	F0814732000	0	NUT M12X1,5	
F0826016	F0826016000	0	LUBRICATOR M6 UNI 7663A	
F0826038	F0826038000	0	LUBRICATOR M8x1,25 UNI 7663A	
F0831148	F0831148000	0	SPRING DM.12,5X45	
F0837554	F0837554000	0	GRIP	
F0864074	F0864074050	0	SPECIAL SCREW M12X1,5	

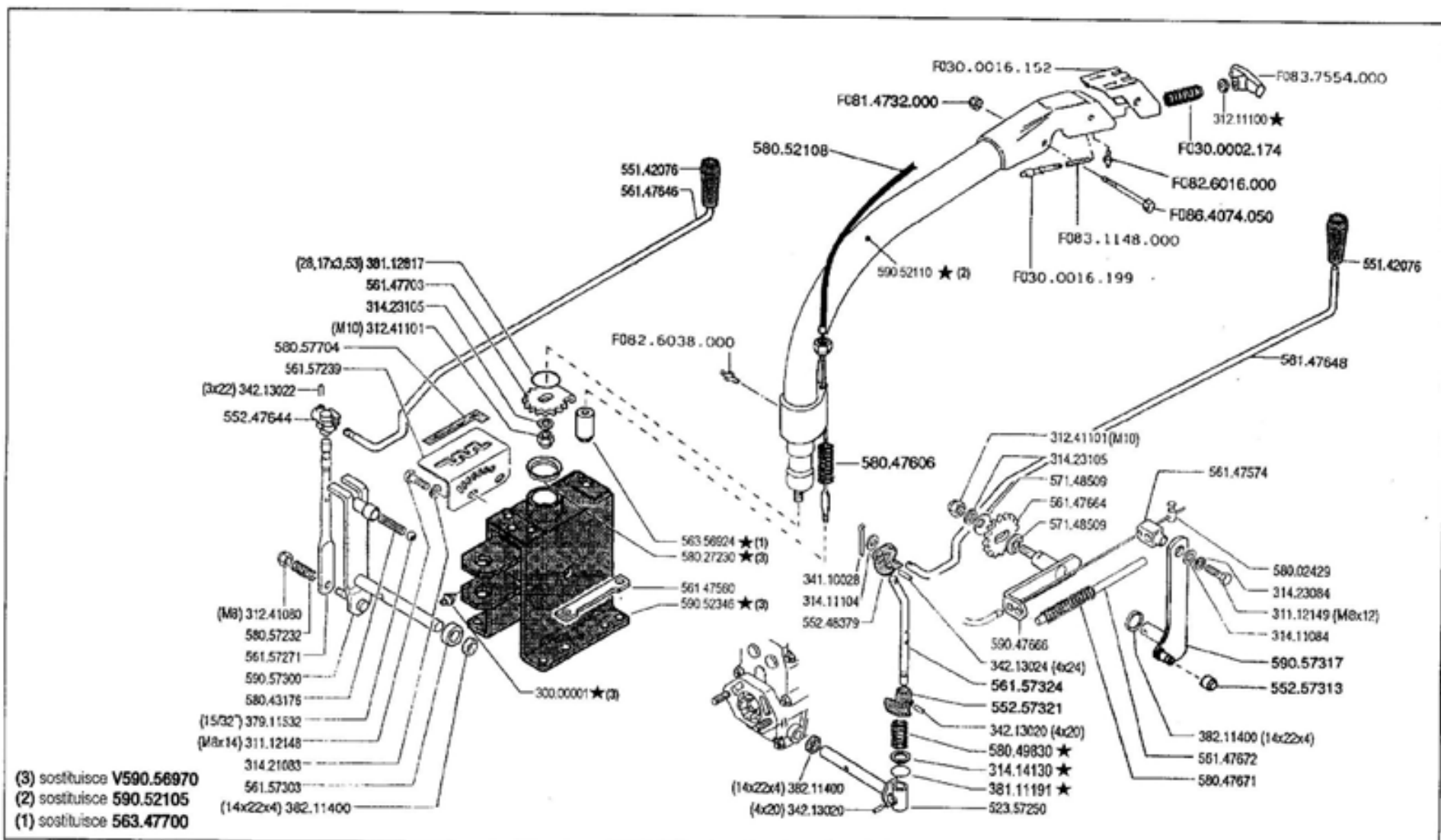

FERRARI

300 serie **95**

PIANTONE E COMANDI (340)

STEERING COLUMN AND CONTROLS
 COLUMNA Y MANDOS

PLANTON ET COMMANDES
 LENKSÄULE UND ANTRIEBE

DALLA MACCHINA
 DE LA MAQUINA
 DE LA MACHINE
 FROM THE MACHINE
 AB DER MASCHINE

★ N.

11

Rev.
2

11328

(1) 9448

11/2001

REV.

Pos.	Code	Q.ty	Description	Notes
30000001	30000001	0	LUBRICATOR M10	
31112148	31112148	0	SCREW TE M8X18 UNI 5739 8G	
31112149	31112149	0	SCREW TE M8X12 UNI 5739 8G	
31211100	31211100	0	NUT M10	
31241080	31241080	0	SELFLOCK NUT M8	
31241101	31241101	0	SELFLOCK NUT M10	
31411084	31411084	0	WASHER 8,4x17	
31411104	31411104	0	WASHER 10,5x18	
31414130	31414130	0	WASHER 13	
31421083	31421083	0	WASHER	
31423084	31423084	0	SPRING WASHER 8,4	
31423105	31423105	0	SPRING WASHER 10,5	
34110028	34110028	0	SPLIT PIN	
34213020	34213020	0	ROLL PIN	
34213022	34213022	0	ROLL PIN	
34213024	34213024	0	ROLL PIN	
37911532	37911532	0	BALL 15/32	
38111191	38111191	0	O-RING 115 (11,91X2,62)	
38112817	38112817	0	O-RING 4112 (28,17X3,53)	
38211400	38211400	0	OIL SEAL 14X22X4	
52357250	52357250	0	PIN	
55142076	55142076	0	KNOB	
55247644	55247644	0	JOINT	
55248379	55248379	0	JOINT	
55257313	55257313	0	ROLLER	
55257321	55257321	0	STOP	
56147560	56147560	0	STOP	
56147574	56147574	0	SMALL BLOCK	
56147646	56147646	0	PULL ROD	
56147648	56147648	0	PULL ROD	
56147664	56147664	0	GEAR	
56147672	56147672	0	GUIDE PIN	
56147703	56147703	0	GEAR	
56157239	56157239	0	GEAR SELECTOR	

SERIAL

STEERING COLUMN AND CONTROLS (340)

CODE REV

011_2_11372

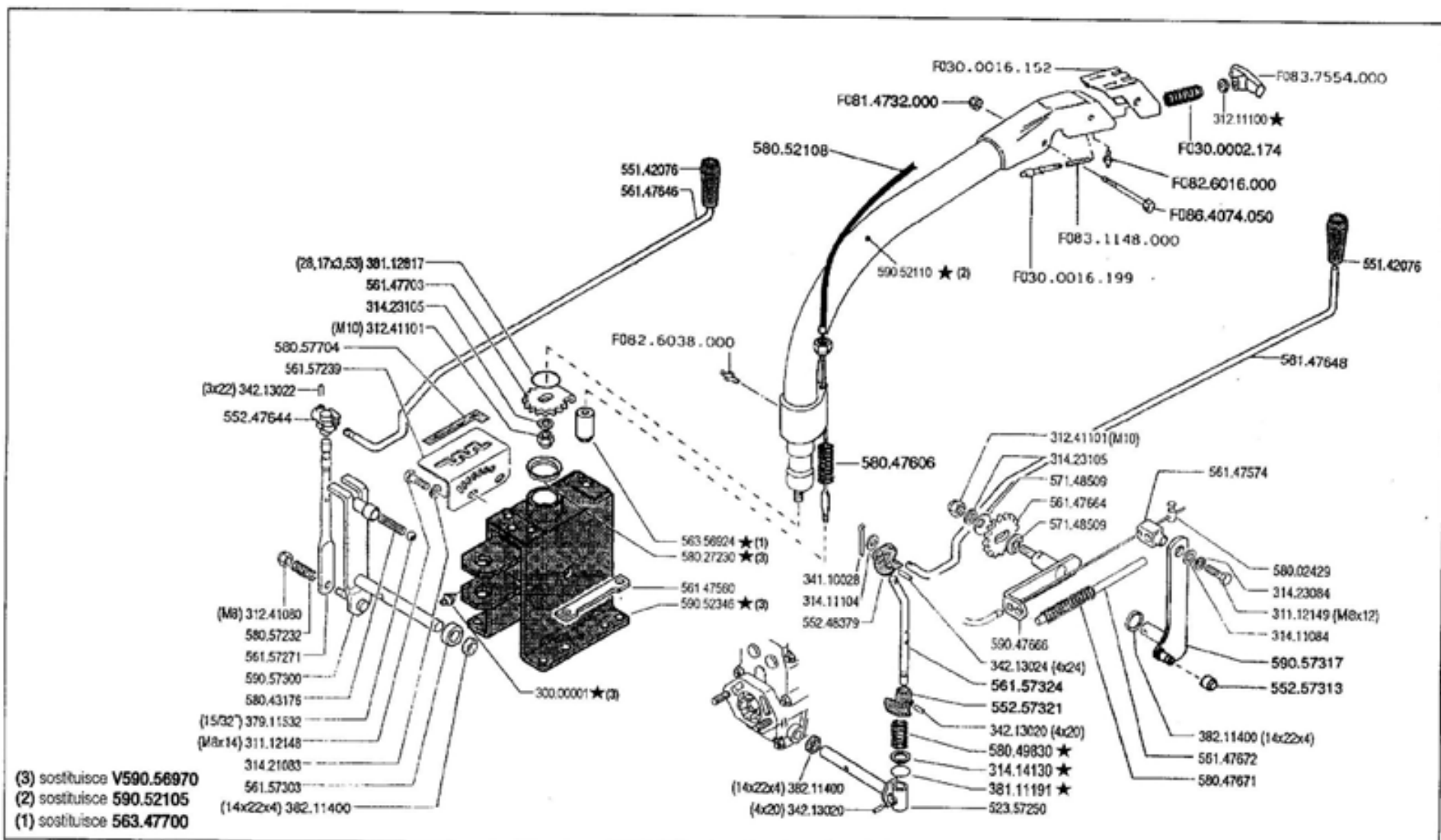

FERRARI

300 serie **95**

PIANTONE E COMANDI (340)

STEERING COLUMN AND CONTROLS
 COLUMNA Y MANDOS

PLANTON ET COMMANDES
 LENKSÄULE UND ANTRIEBE

DALLA MACCHINA
 DE LA MAQUINA
 DE LA MACHINE
 FROM THE MACHINE
 AB DER MASCHINE

★ N.

11

Rev. **2**

11328

(1) 9448

11/2001

REV.

Pos.	Code	Q.ty	Description	Notes
56157271	56157271	0	COMMAND LEVER	
56157303	56157303	0	SPACER	
56157324	56157324	0	PTO LEVER	
56356924	56356924	0	FERRULE	
57148509	57148509	0	BOTTOM	
58002429	58002429	0	CLAMPING SCREW	
58027230	58027230	0	RING	
58043176	58043176	0	SPRING	
58047606	58047606	0	SPRING	
58047671	58047671	0	SPRING	
58049830	58049830	0	SPRING	
58052108	58052108	0	CABLE	
58057232	58057232	0	SPRING	
58057704	58057704	0	DECAL	
59047666	59047666	0	COMMAND LEVER	
59052110	59052110	0	PLOUGHTAIL	
59052346	59052346	0	SUPPORT	
59057300	59057300	0	GEAR LEVER	
59057317	59057317	0	LEVER	
F0300002	F0300002174	0	BELLOWS	
F0300016	F0300016152	0	SUMP	
F0300016	F0300016199	0	STAKE	
F0814732	F0814732000	0	NUT M12X1,5	
F0826016	F0826016000	0	LUBRICATOR M6 UNI 7663A	
F0826038	F0826038000	0	LUBRICATOR M8x1,25 UNI 7663A	
F0831148	F0831148000	0	SPRING DM.12,5X45	
F0837554	F0837554000	0	GRIP	
F0864074	F0864074050	0	SPECIAL SCREW M12X1,5	

SERIAL

STEERING COLUMN AND CONTROLS (340)

CODE REV

011_2_11372

Pos.	Code	Q.ty	Description	Notes
30000001	30000001	0	LUBRICATOR M10	
31112148	31112148	0	SCREW TE M8X18 UNI 5739 8G	
31112149	31112149	0	SCREW TE M8X12 UNI 5739 8G	
31211100	31211100	0	NUT M10	
31241080	31241080	0	SELFLOCK NUT M8	
31241101	31241101	0	SELFLOCK NUT M10	
31411084	31411084	0	WASHER 8,4x17	
31411104	31411104	0	WASHER 10,5x18	
31414130	31414130	0	WASHER 13	
31421083	31421083	0	WASHER	
31423084	31423084	0	SPRING WASHER 8,4	
31423105	31423105	0	SPRING WASHER 10,5	
34110028	34110028	0	SPLIT PIN	
34213020	34213020	0	ROLL PIN	
34213022	34213022	0	ROLL PIN	
34213024	34213024	0	ROLL PIN	
37911532	37911532	0	BALL 15/32	
38111191	38111191	0	O-RING 115 (11,91X2,62)	
38112817	38112817	0	O-RING 4112 (28,17X3,53)	
38211400	38211400	0	OIL SEAL 14X22X4	
52357250	52357250	0	PIN	
55142076	55142076	0	KNOB	
55247644	55247644	0	JOINT	
55248379	55248379	0	JOINT	
55257313	55257313	0	ROLLER	
55257321	55257321	0	STOP	
56147560	56147560	0	STOP	
56147574	56147574	0	SMALL BLOCK	
56147646	56147646	0	PULL ROD	
56147648	56147648	0	PULL ROD	
56147664	56147664	0	GEAR	
56147672	56147672	0	GUIDE PIN	
56147703	56147703	0	GEAR	
56157239	56157239	0	GEAR SELECTOR	

SERIAL

STEERING COLUMN AND CONTROLS (340)

CODE REV

011_3_11435

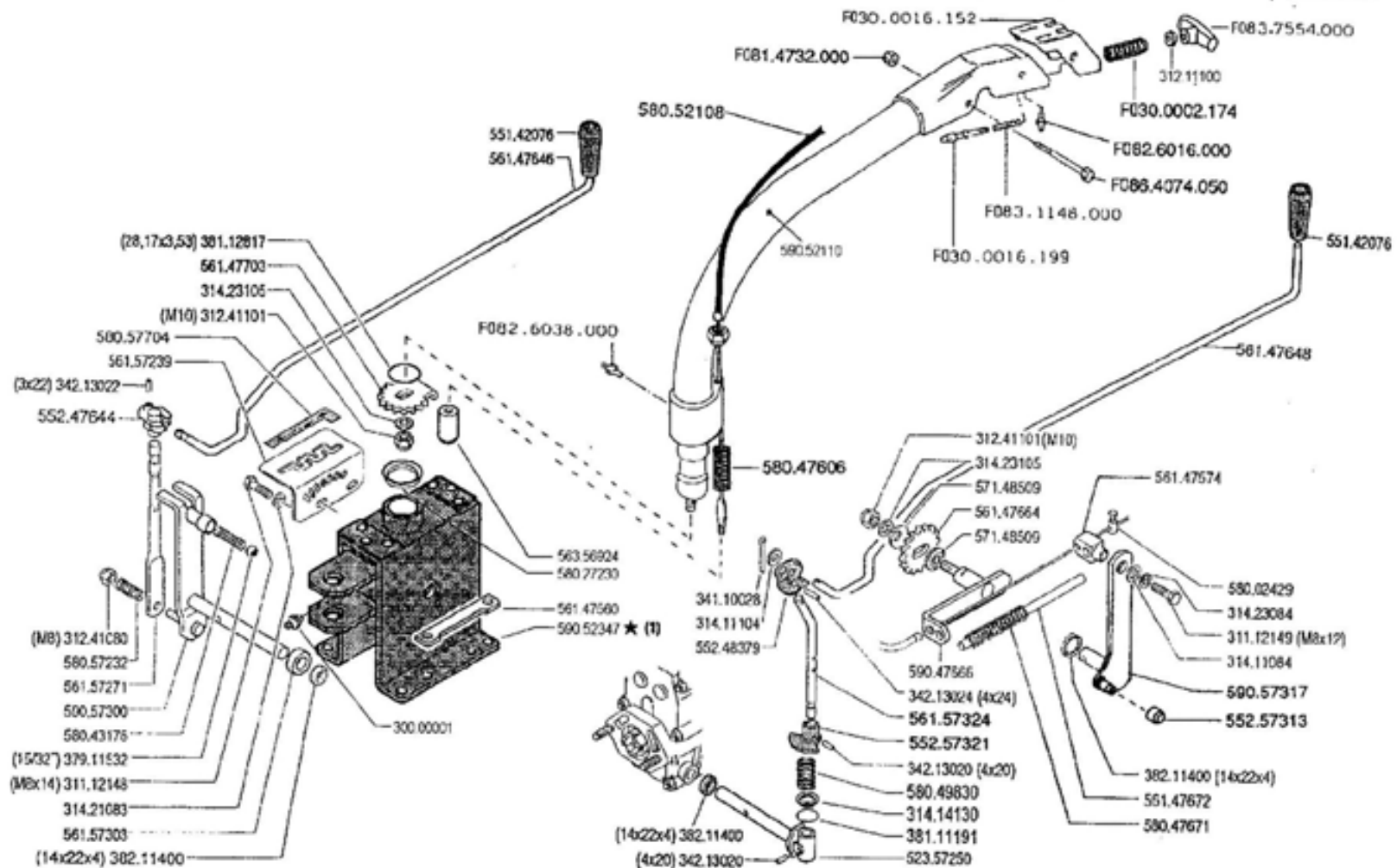

(1) sostituisce 590.52346

FERRARI

300 serie 95

PIANTONE E COMANDI (340)

STEERING COLUMN AND CONTROLS
COLUMNA Y MANDOS

PLANTON ET COMMANDES
LENKSÄULE UND ANTRIEBE

DALLA MACCHINA
DE LA MAQUINA
DE LA MACHINE
FROM THE MACHINE
AB DER MASCHINE

AGGIORNAMENTO
REVISION
MISE A JOUR
APLAZAMIENTO
ANPASSUNG

11

Rev.
3

★N

2/2003

REV.

Pos.	Code	Q.ty	Description	Notes
56157271	56157271	0	COMMAND LEVER	
56157303	56157303	0	SPACER	
56157324	56157324	0	PTO LEVER	
56356924	56356924	0	FERRULE	
57148509	57148509	0	BOTTOM	
58002429	58002429	0	CLAMPING SCREW	
58027230	58027230	0	RING	
58043176	58043176	0	SPRING	
58047606	58047606	0	SPRING	
58047671	58047671	0	SPRING	
58049830	58049830	0	SPRING	
58052108	58052108	0	CABLE	
58057232	58057232	0	SPRING	
58057704	58057704	0	DECAL	
59047666	59047666	0	COMMAND LEVER	
59052110	59052110	0	PLOUGHTAIL	
59052347	59052347	0	SUPPORT	
59057300	59057300	0	GEAR LEVER	
59057317	59057317	0	LEVER	
F0300002	F0300002174	0	BELLOWS	
F0300016	F0300016152	0	SUMP	
F0300016	F0300016199	0	STAKE	
F0814732	F0814732000	0	NUT M12X1,5	
F0826016	F0826016000	0	LUBRICATOR M6 UNI 7663A	
F0826038	F0826038000	0	LUBRICATOR M8x1,25 UNI 7663A	
F0831148	F0831148000	0	SPRING DM.12,5X45	
F0837554	F0837554000	0	GRIP	
F0864074	F0864074050	0	SPECIAL SCREW M12X1,5	

SERIAL

STEERING COLUMN AND CONTROLS (340)

CODE REV

011_3_11435

BENZINA
GASOLINE
ESSENCE
GASOLINA
BENZIN

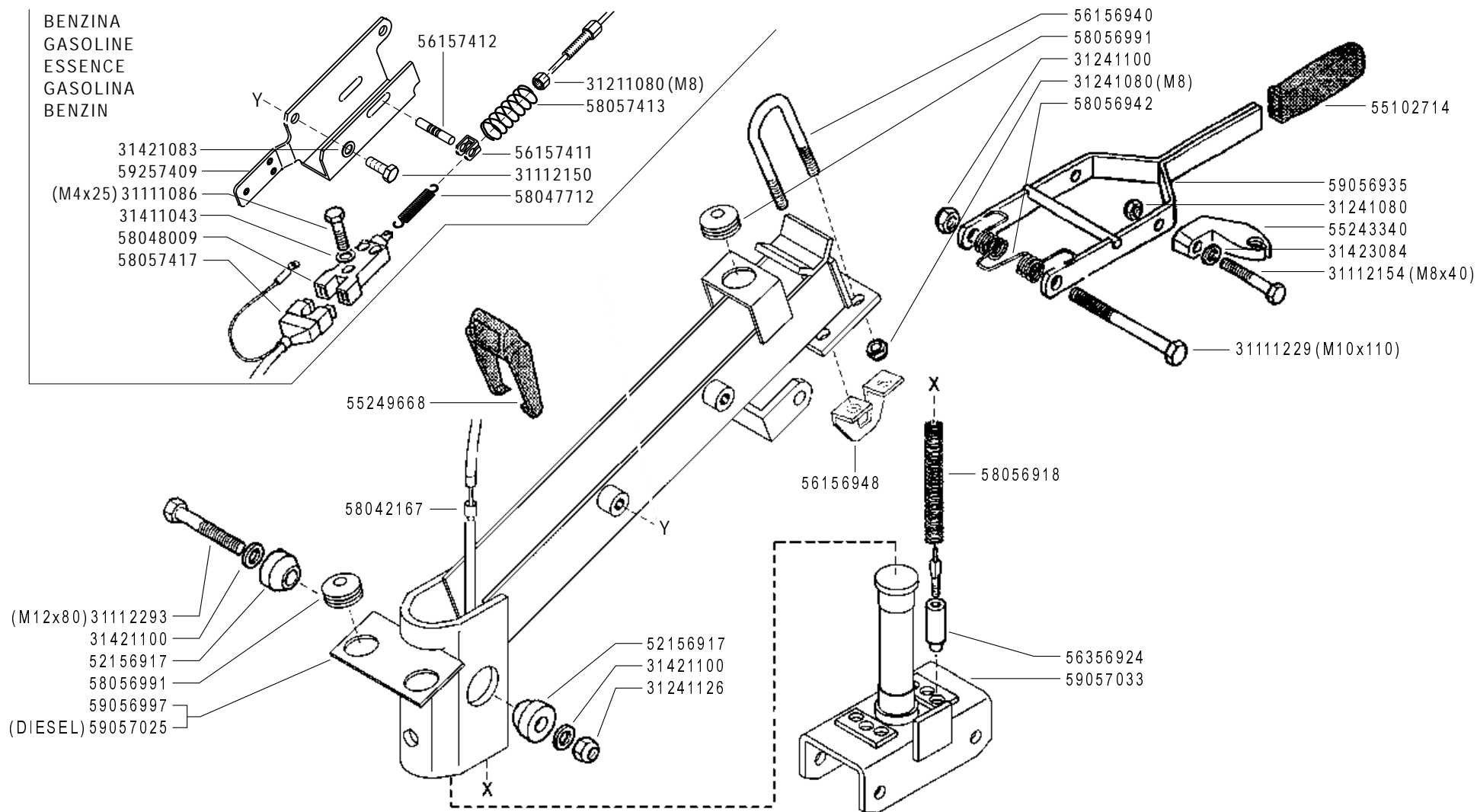

FERRARI

300 serie 95

PIANTONE (340-346) ★

STEERING COLUMN
COLUMNA

PLANTON
LENKSÄULE

DALLA MACCHINA
DE LA MAQUINA
DE LA MACHINE
FROM THE MACHINE
AB DER MASCHINE

★ N.

752002 (346)

749391 (340)

11

Rev.
4

02/2006

ZENNE

Pos.	Code	Q.ty	Description	Notes
31111086	31111086	1	SCREW TE M4X25 UNI 5739 8G	
31111229	31111229	1	SCREW TE M10X110 UNI 5737 8G	
31112150	31112150	1	SCREW TE M8X20 UNI 5739 8G	
31112154	31112154	1	SCREW TE M8X40 UNI 5739 8G	
31112293	31112293	1	SCREW TE M12X80 UNI 5737	
31211080	31211080	1	NUT M8	
31241080	31241080	1	SELFLOCK NUT M8	
31241100	31241100	1	SELFLOCK NUT M10 6S	
31241126	31241126	1	SELFLOCK NUT M12	
31411043	31411043	1	WASHER 4,3X9	
31421083	31421083	1	WASHER	
31421100	31421100	1	CUP SPRING	
31423084	31423084	1	SPRING WASHER 8,4	
52156917	52156917	1	WEDGE	
55102714	55102714	1	KNOB	
55243340	55243340	1	SUPPORT	
55249668	55249668	1	PASSING	
56156940	56156940	1	U BOLT	
56156948	56156948	1	STOP	
56157411	56157411	1	FORK	
56157412	56157412	1	PIN	
56356924	56356924	1	FERRULE	
58042167	58042167	1	SHEATH TERMINAL	
58047712	58047712	1	SPRING	
58048009	58048009	1	SWITCH	
58056918	58056918	1	SPRING	
58056942	58056942	1	SPRING	
58056991	58056991	1	CABLE GLAND	
58057413	58057413	1	RETAINING SPRING	
58057417	58057417	1	WIRING	
59056935	59056935	1	LEVER	
59056997	59056997	1	COLUMN	
59057025	59057025	1	COLUMN	
59057033	59057033	1	CONNECTION	

SERIAL

STEERING COLUMN (340-346)

Version: MC 346, MC 340

CODE REV

011_4_25304

BENZINA
GASOLINE
ESSENCE
GASOLINA
BENZIN

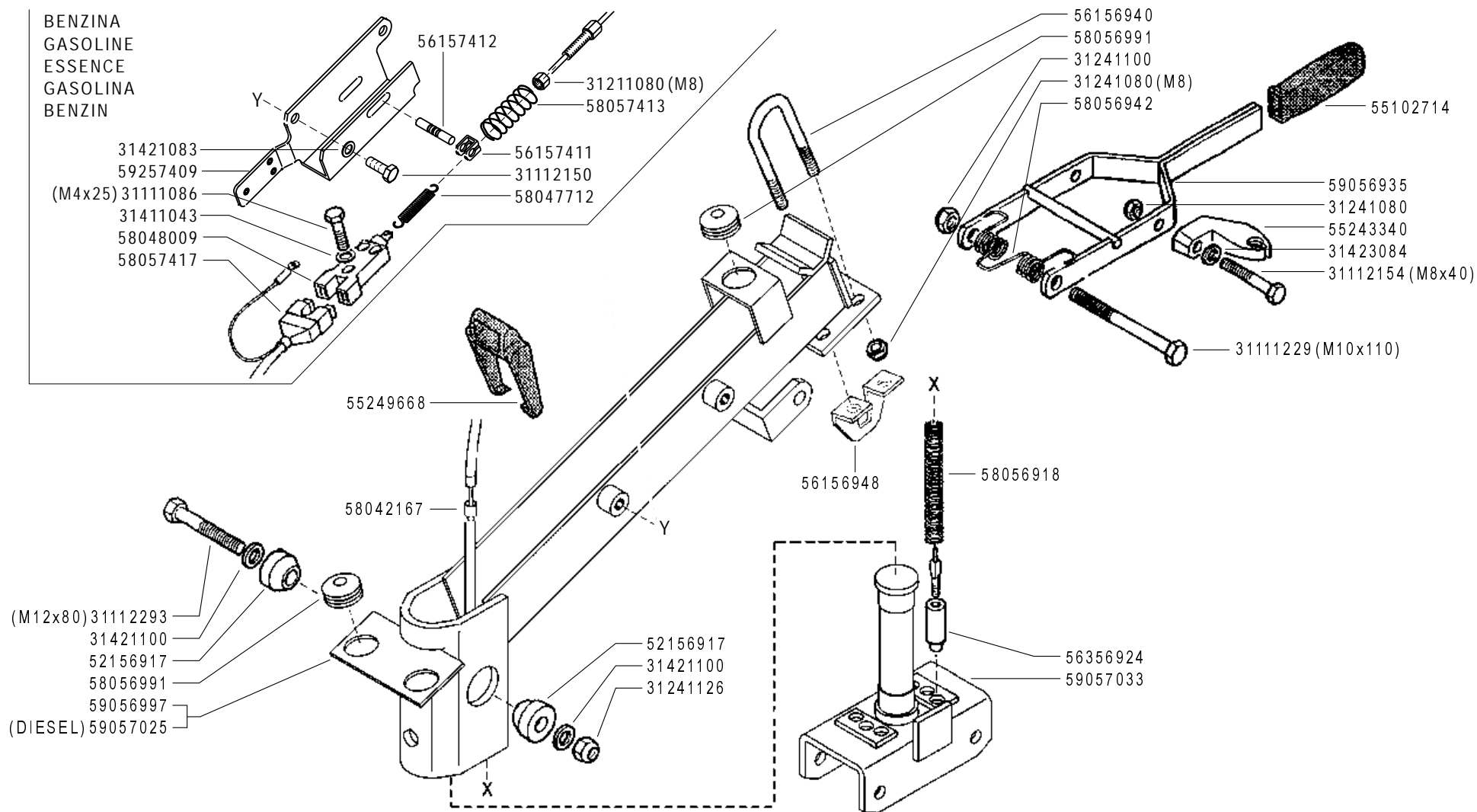

FERRARI

300 serie 95

PIANTONE (340-346) ★

STEERING COLUMN
COLUMNA

PLANTON
LENKSÄULE

DALLA MACCHINA
DE LA MAQUINA
DE LA MACHINE
FROM THE MACHINE
AB DER MASCHINE

★ N.

752002 (346)

749391 (340)

11

Rev.
4

02/2006

ZENNE

Pos.	Code	Q.ty	Description	Notes
59257409	59257409	1	SUPPORT	

SERIAL

STEERING COLUMN (340-346)

Version: MC 346, MC 340

CODE REV

011_4_25304

BENZINA
GASOLINE
ESSENCE
GASOLINA
BENZIN

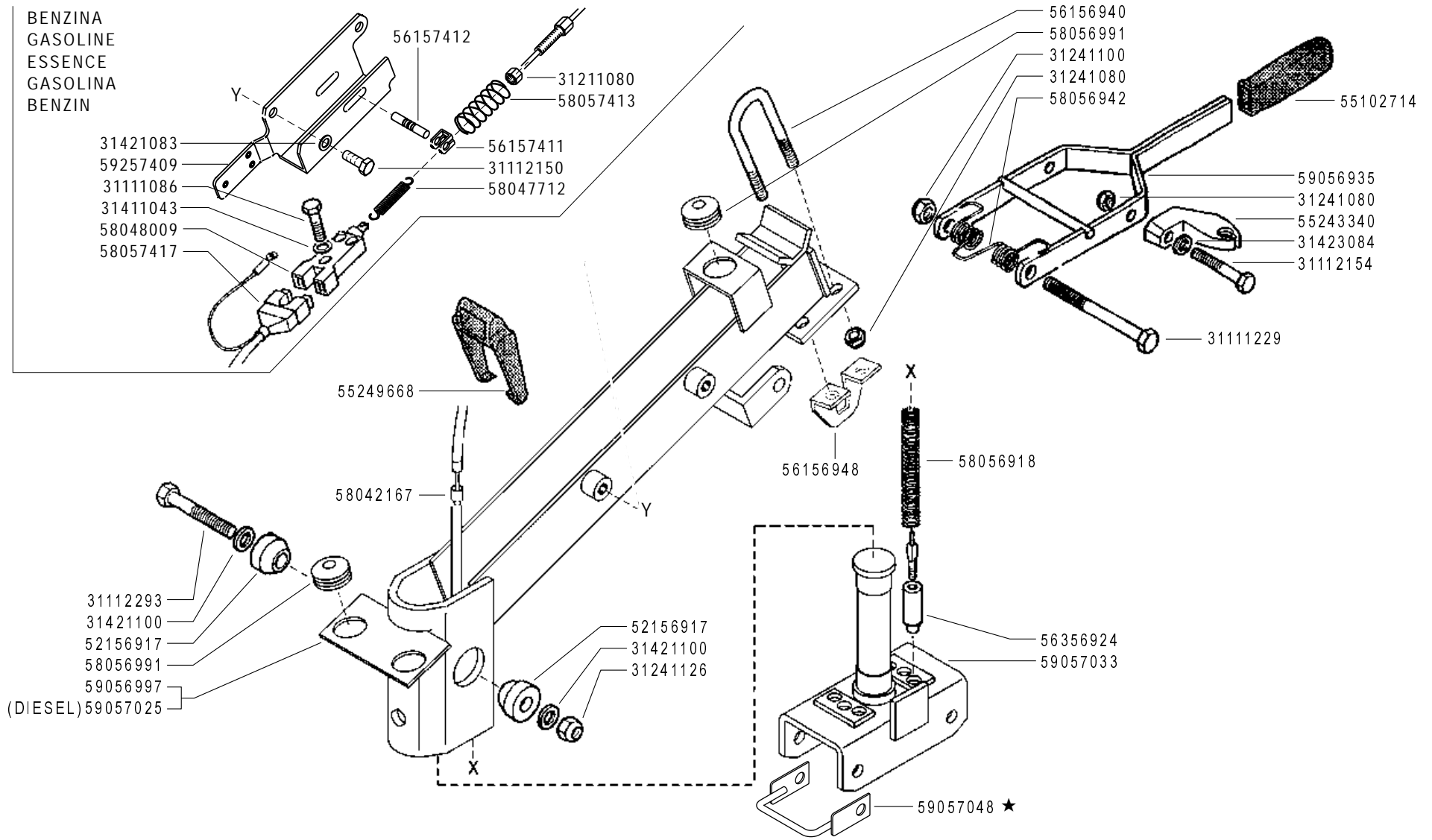

PIANTONE (340-346)

STEERING COLUMN
COLUMNA

PLANTON
LENKSÄULE

DALLA MACCHINA
DE LA MAQUINA
DE LA MACHINE
FROM THE MACHINE
AB DER MASCHINE

AGGIORNAMENTO

REVISION

MISE A JOUR

APLAZAMIENTO

ANPASSUNG

Rev.

11

5

06/2006

★ N.

ZENNE

FERRARI

300 serie 95

Pos.	Code	Q.ty	Description	Notes
31111086	31111086	1	SCREW TE M4X25 UNI 5739 8G	
31111229	31111229	1	SCREW TE M10X110 UNI 5737 8G	
31112150	31112150	1	SCREW TE M8X20 UNI 5739 8G	
31112154	31112154	1	SCREW TE M8X40 UNI 5739 8G	
31112293	31112293	1	SCREW TE M12X80 UNI 5737	
31211080	31211080	1	NUT M8	
31241080	31241080	1	SELFLOCK NUT M8	
31241100	31241100	1	SELFLOCK NUT M10 6S	
31241126	31241126	1	SELFLOCK NUT M12	
31411043	31411043	1	WASHER 4,3X9	
31421083	31421083	1	WASHER	
31421100	31421100	1	CUP SPRING	
31423084	31423084	1	SPRING WASHER 8,4	
52156917	52156917	1	WEDGE	
55102714	55102714	1	KNOB	
55243340	55243340	1	SUPPORT	
55249668	55249668	1	PASSING	
56156940	56156940	1	U BOLT	
56156948	56156948	1	STOP	
56157411	56157411	1	FORK	
56157412	56157412	1	PIN	
56356924	56356924	1	FERRULE	
58042167	58042167	1	SHEATH TERMINAL	
58047712	58047712	1	SPRING	
58048009	58048009	1	SWITCH	
58056918	58056918	1	SPRING	
58056942	58056942	1	SPRING	
58056991	58056991	1	CABLE GLAND	
58057413	58057413	1	RETAINING SPRING	
58057417	58057417	1	WIRING	
59056935	59056935	1	LEVER	
59056997	59056997	1	COLUMN	
59057025	59057025	1	COLUMN	
59057033	59057033	1	CONNECTION	

SERIAL

STEERING COLUMN (340-346)

CODE REV

011_5_32699

BENZINA
GASOLINE
ESSENCE
GASOLINA
BENZIN

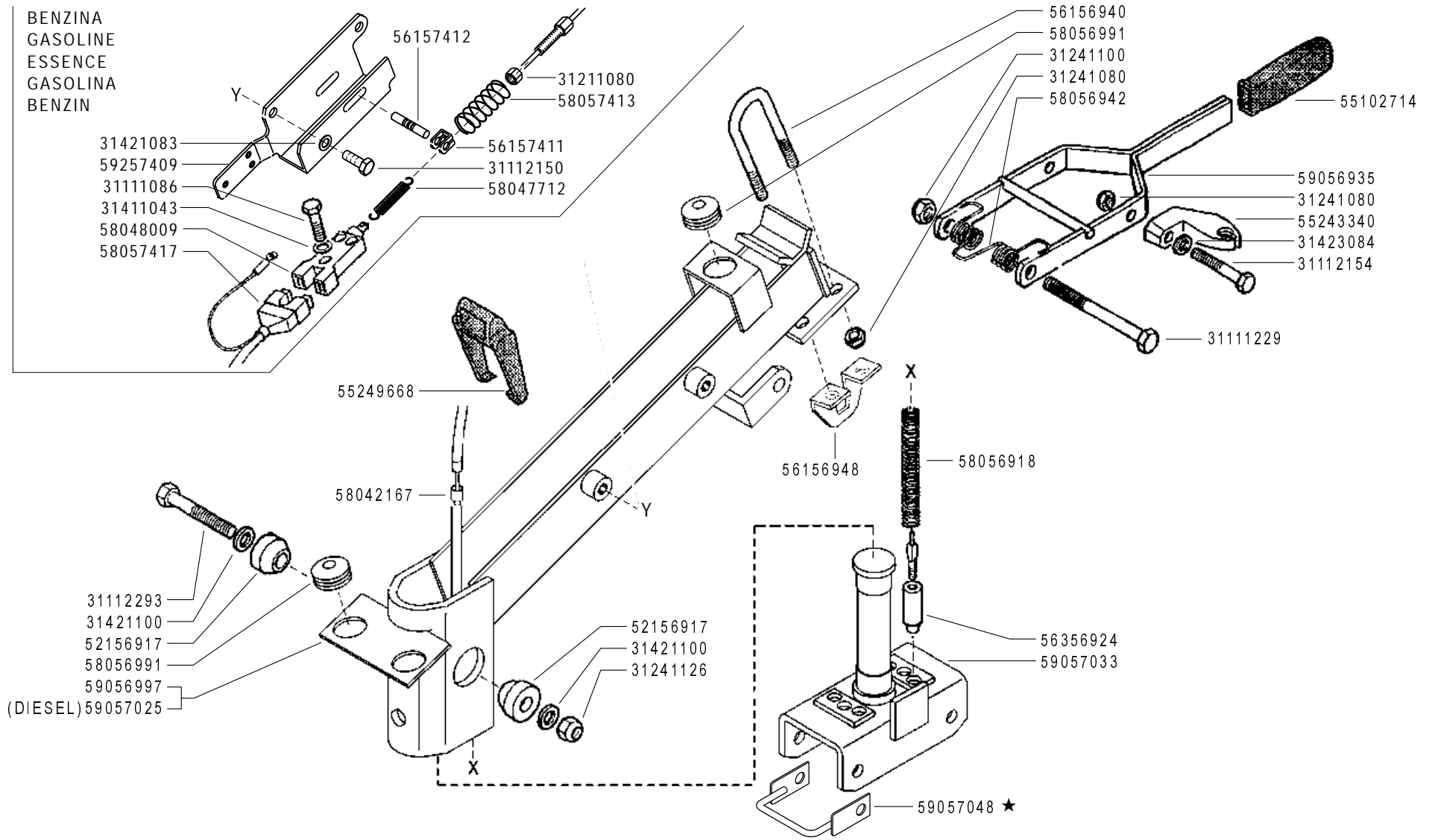

PIANTONE (340-346)

STEERING COLUMN
COLUMNA

PLANTON
LENKSÄULE

DALLA MACCHINA
DE LA MAQUINA
DE LA MACHINE
FROM THE MACHINE
AB DER MASCHINE

AGGIORNAMENTO

REVISION

MISE A JOUR

APLAZAMIENTO

ANPASSUNG

Rev.

11

5

★ N.

06/2006

ZENNE

FERRARI

300 serie 95

Pos.	Code	Q.ty	Description	Notes
59057048	59057048	1	SHEATH FASTENER	
59257409	59257409	1	SUPPORT	

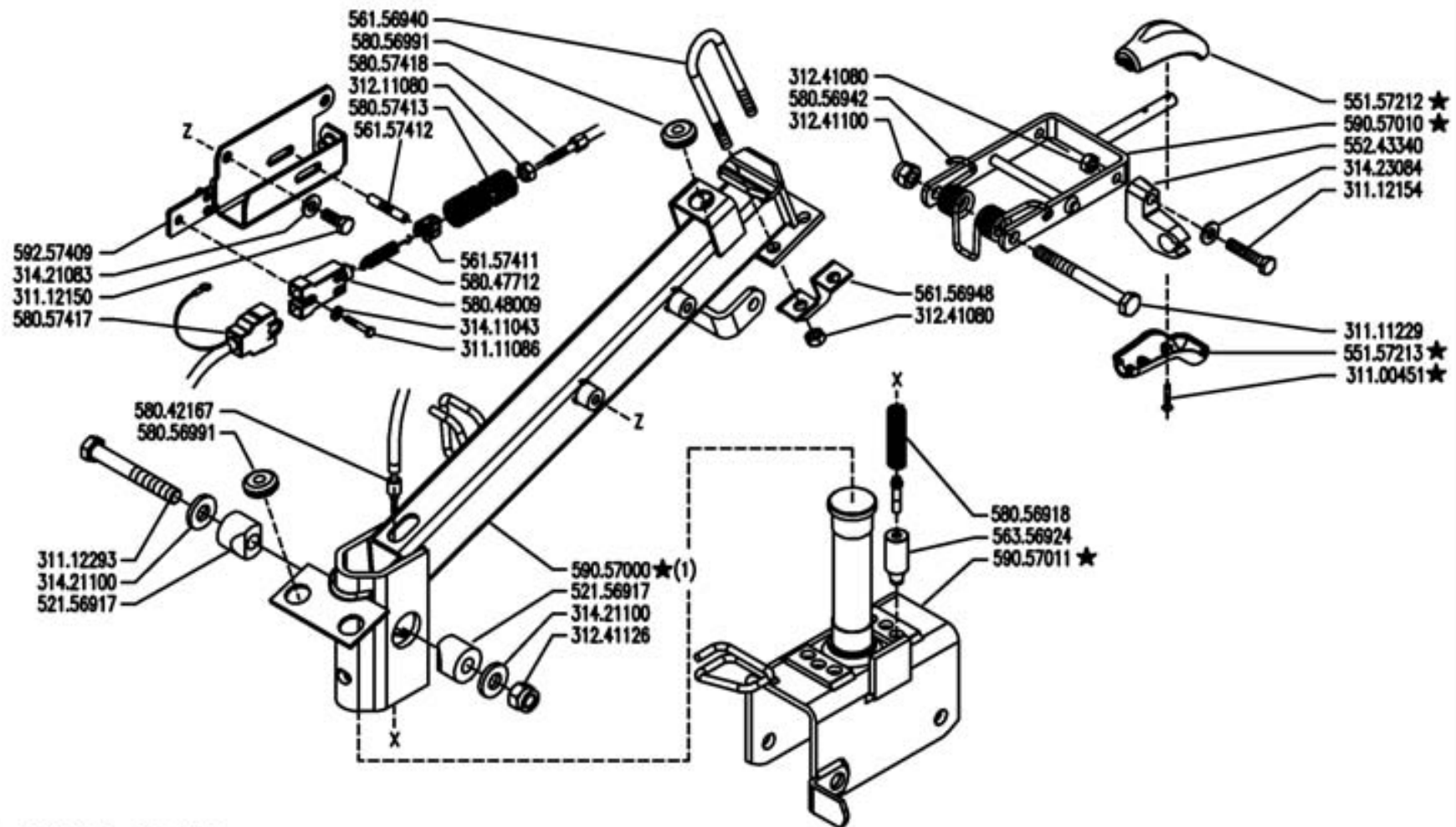

(1) sostituisce 590.56997 e 590.57025

FERRARI

300 serie 95

PIANTONE (340-346)

STEERING COLUMN
COLUMNNA

PLANTON
LENKSÄULE

DALLA MACCHINA
DE LA MACCHINA
FROM THE MACHINE
AB DER MASCHINE

★ N.

783462

11 6

01/2007

Rev.

INT

Pos.	Code	Q.ty	Description	Notes
31100451	31100451	1	SCREW 3,5X25	
31111086	31111086	1	SCREW TE M4X25 UNI 5739 8G	
31111229	31111229	1	SCREW TE M10X110 UNI 5737 8G	
31112150	31112150	1	SCREW TE M8X20 UNI 5739 8G	
31112154	31112154	1	SCREW TE M8X40 UNI 5739 8G	
31112293	31112293	1	SCREW TE M12X80 UNI 5737	
31211080	31211080	1	NUT M8	
31241080	31241080	1	SELFLOCK NUT M8	
31241100	31241100	1	SELFLOCK NUT M10 6S	
31241126	31241126	1	SELFLOCK NUT M12	
31411043	31411043	1	WASHER 4,3X9	
31421083	31421083	1	WASHER	
31421100	31421100	1	CUP SPRING	
31423084	31423084	1	SPRING WASHER 8,4	
52156917	52156917	1	WEDGE	
55157212	55157212	1	GRIP	
55157213	55157213	1	GRIP	
55243340	55243340	1	SUPPORT	
56156940	56156940	1	U BOLT	
56156948	56156948	1	STOP	
56157411	56157411	1	FORK	
56157412	56157412	1	PIN	
56356924	56356924	1	FERRULE	
58042167	58042167	1	SHEATH TERMINAL	
58047712	58047712	1	SPRING	
58048009	58048009	1	SWITCH	
58056918	58056918	1	SPRING	
58056942	58056942	1	SPRING	
58056991	58056991	1	CABLE GLAND	
58057413	58057413	1	RETAINING SPRING	
58057417	58057417	1	WIRING	
59057000	59057000	1	COLUMN	
59057010	59057010	1	LEVER	
59057011	59057011	1	CONNECTION	

SERIAL
START
783462

END
794195

STEERING COLUMN (340-346)

CODE REV
011_6_33168

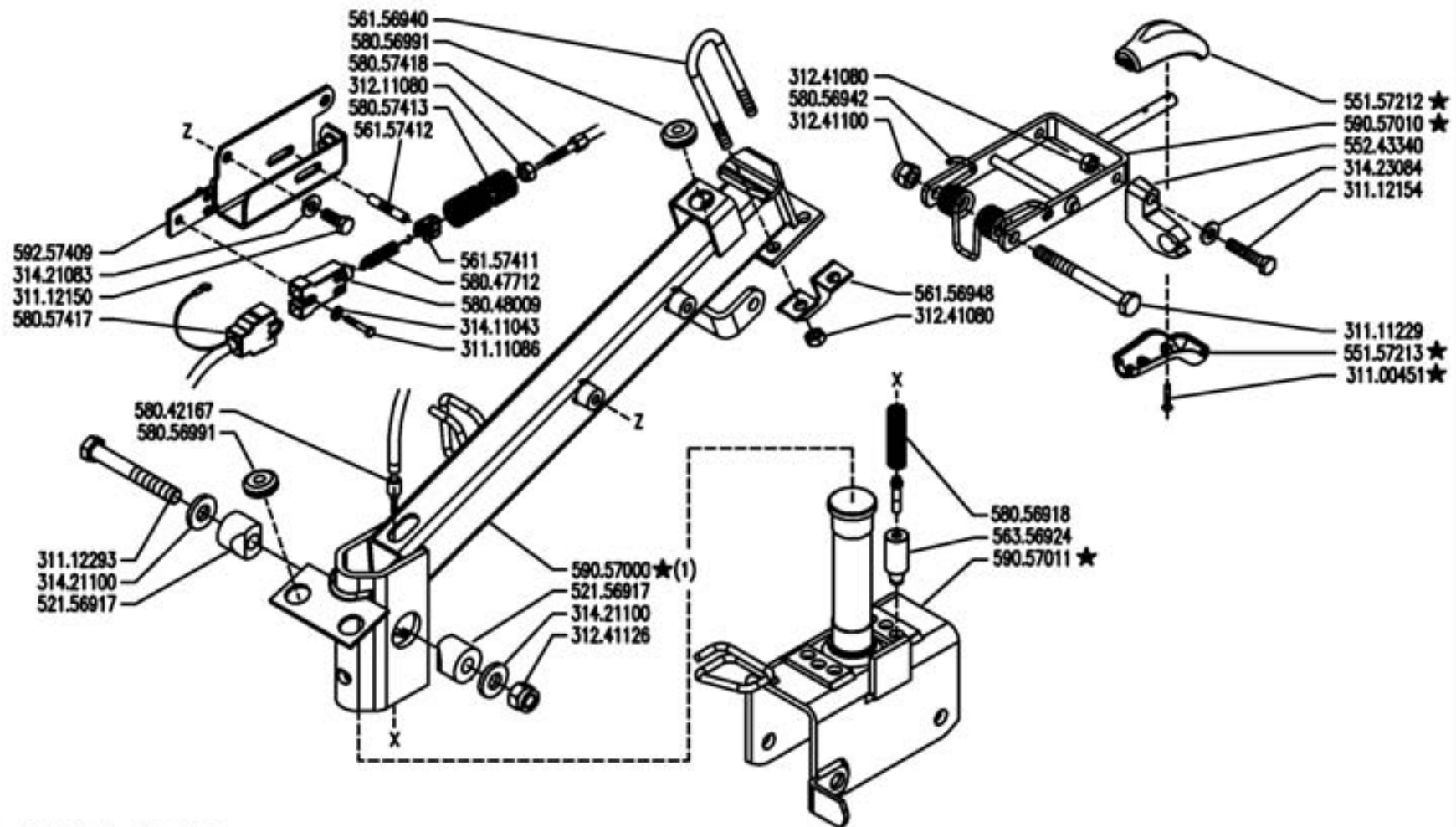

(1) sostituisce 590.56997 e 590.57025

FERRARI

300 serie 95

PIANTONE (340-346)

STEERING COLUMN
COLUMNNA

PLANTON
LENKSÄULE

DALLA MACCHINA
DE LA MACCHINA
FROM THE MACHINE
AB DER MASCHINE

★ N.

783462

11

Rev.
6

01/2007

INT

Pos.	Code	Q.ty	Description	Notes
59257409	59257409	1	SUPPORT	

SERIAL
START
783462

END
794195

STEERING COLUMN (340-346)

CODE REV
011_6_33168

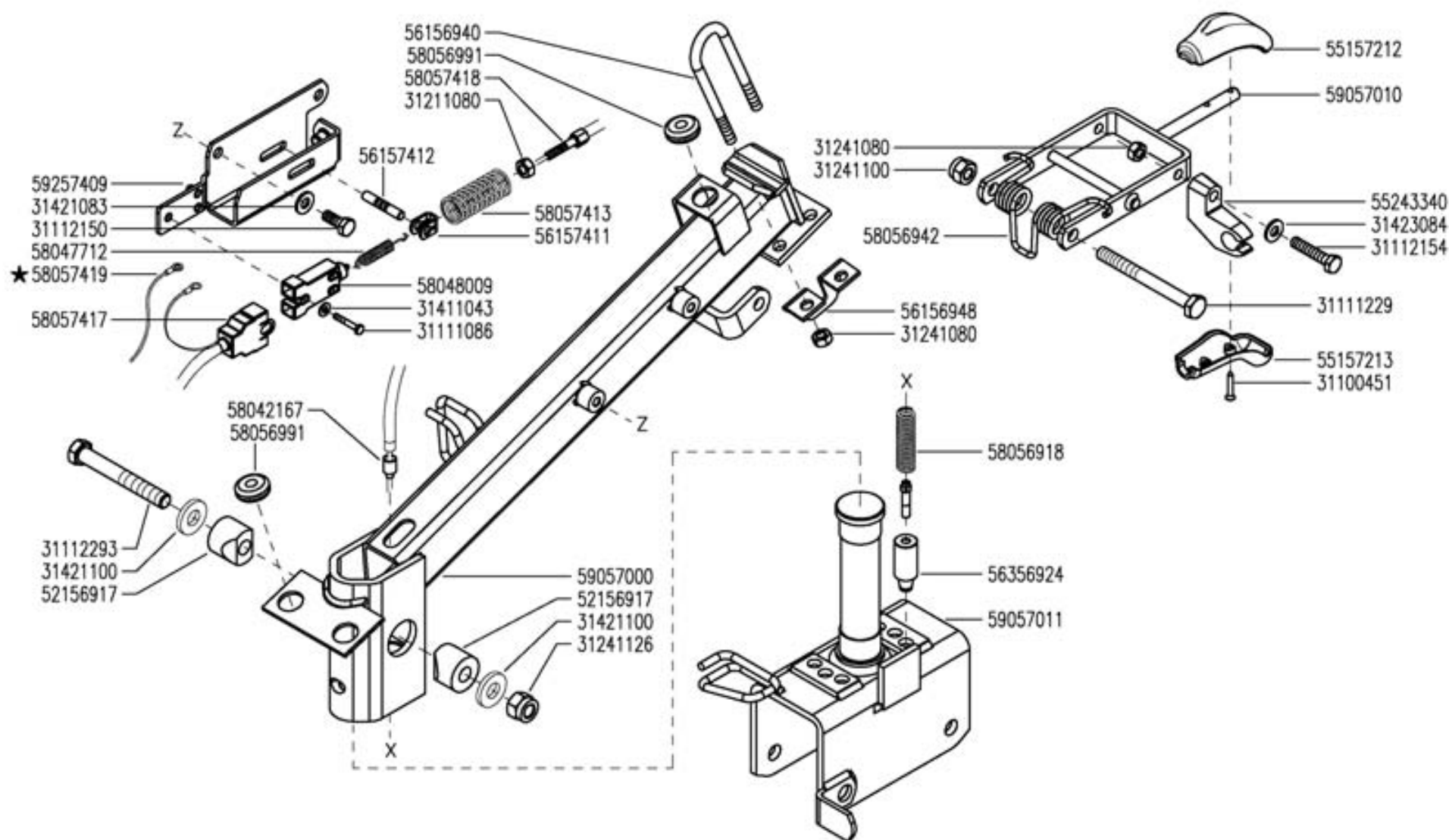

FERRARI

300 serie 95

PIANTONE (340 - 346)

STEERING COLUMN
COLUMNA

PLANTON
LENKSÄULE

DALLA MACCHINA
DE LA MACQUINA
DE LA MACHINE
FROM THE MACHINE
AB DER MASCHINE

★ N.

794196

11

Rev.
7

06/2007

ZFINF

Pos.	Code	Q.ty	Description	Notes
31100451	31100451	1	SCREW 3,5X25	
31111086	31111086	1	SCREW TE M4X25 UNI 5739 8G	
31111229	31111229	1	SCREW TE M10X110 UNI 5737 8G	
31112150	31112150	1	SCREW TE M8X20 UNI 5739 8G	
31112154	31112154	1	SCREW TE M8X40 UNI 5739 8G	
31112293	31112293	1	SCREW TE M12X80 UNI 5737	
31211080	31211080	1	NUT M8	
31241080	31241080	1	SELFLOCK NUT M8	
31241100	31241100	1	SELFLOCK NUT M10 6S	
31241126	31241126	1	SELFLOCK NUT M12	
31411043	31411043	1	WASHER 4,3X9	
31421083	31421083	1	WASHER	
31421100	31421100	1	CUP SPRING	
31423084	31423084	1	SPRING WASHER 8,4	
52156917	52156917	1	WEDGE	
55157212	55157212	1	GRIP	
55157213	55157213	1	GRIP	
55243340	55243340	1	SUPPORT	
56156940	56156940	1	U BOLT	
56156948	56156948	1	STOP	
56157411	56157411	1	FORK	
56157412	56157412	1	PIN	
56356924	56356924	1	FERRULE	
58042167	58042167	1	SHEATH TERMINAL	
58047712	58047712	1	SPRING	
58048009	58048009	1	SWITCH	
58056918	58056918	1	SPRING	
58056942	58056942	1	SPRING	
58056991	58056991	1	CABLE GLAND	
58057413	58057413	1	RETAINING SPRING	
58057417	58057417	1	WIRING	
58057419	58057419	1	WIRING	
59057000	59057000	1	COLUMN	
59057010	59057010	1	LEVER	

SERIAL
START
794196

STEERING COLUMN (340-346)

CODE REV
011_7_63924

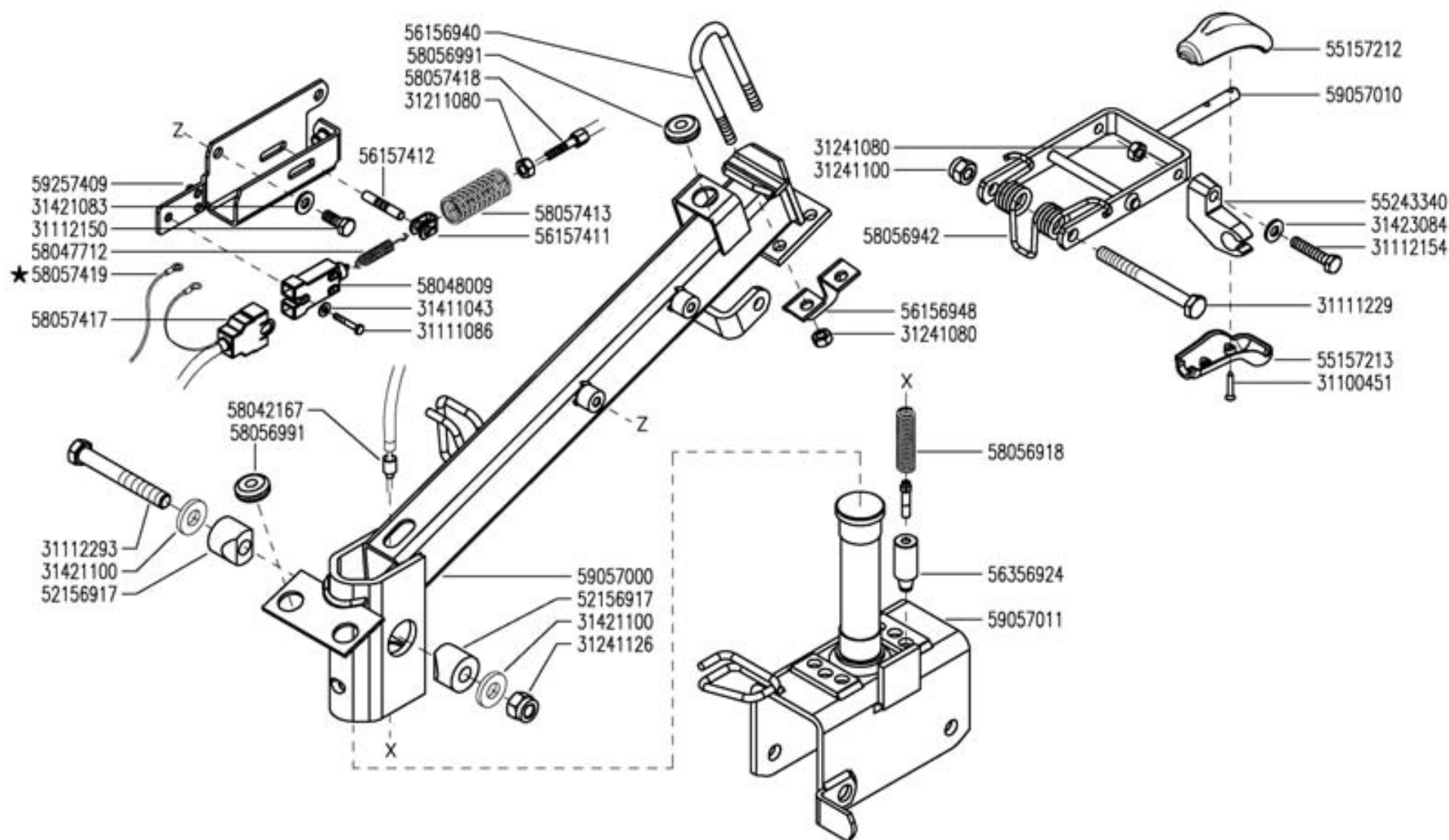

FERRARI

300 serie 95

PIANTONE (340 - 346)

STEERING COLUMN
COLUMNA

PLANTON
LENKSÄULE

DALLA MACCHINA
DE LA MACQUINA
DE LA MACHINE
FROM THE MACHINE
AB DER MASCHINE

★ N.

794196

11

Rev.
7

06/2007

ZFINF

Pos.	Code	Q.ty	Description	Notes
59057011	59057011	1	CONNECTION	
59257409	59257409	1	SUPPORT	

SERIAL
START
794196

STEERING COLUMN (340-346)

CODE REV
011_7_63924

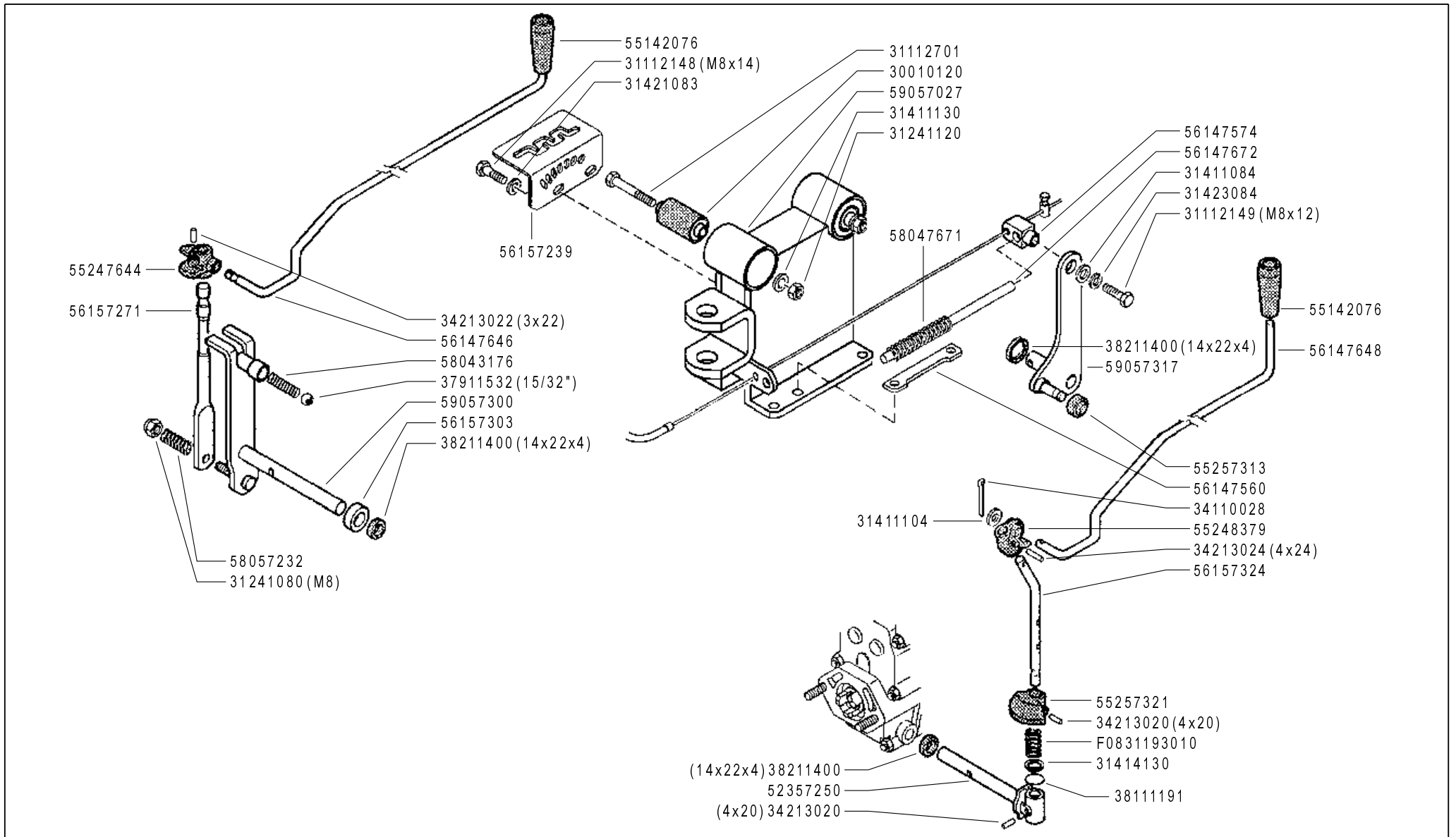

	300 serie 95	CONTROLS MANDOS	COMANDI (340-346) ★	COMMANDES ANTRIEBE	DALLA MACCHINA DE LA MAQUINA FROM THE MACHINE AB DER MASCHINE ★ N.	Rev.	11 A 0
						752002 (346) 749391 (340)	

Pos.	Code	Q.ty	Description	Notes
30010120	30010120	1	SILENT-BLOCK 12X40X58X66	
31112148	31112148	1	SCREW TE M8X18 UNI 5739 8G	
31112149	31112149	1	SCREW TE M8X12 UNI 5739 8G	
31112701	31112701	1	SCREW TE M12X100 UNI 5737	
31241080	31241080	1	SELFLOCK NUT M8	
31241120	31241120	1	SELFLOCK NUT M12	
31411084	31411084	1	WASHER 8,4x17	
31411104	31411104	1	WASHER 10,5x18	
31411130	31411130	1	WASHER 13x24	
31414130	31414130	1	WASHER 13	
31421083	31421083	1	WASHER	
31423084	31423084	1	SPRING WASHER 8,4	
34110028	34110028	1	SPLIT PIN	
34213020	34213020	1	ROLL PIN	
34213022	34213022	1	ROLL PIN	
34213024	34213024	1	ROLL PIN	
37911532	37911532	1	BALL 15/32	
38111191	38111191	1	O-RING 115 (11,91X2,62)	
38211400	38211400	1	OIL SEAL 14X22X4	
52357250	52357250	1	PIN	
55142076	55142076	1	KNOB	
55247644	55247644	1	JOINT	
55248379	55248379	1	JOINT	
55257313	55257313	1	ROLLER	
55257321	55257321	1	STOP	
56147560	56147560	1	STOP	
56147574	56147574	1	SMALL BLOCK	
56147646	56147646	1	PULL ROD	
56147672	56147672	1	GUIDE PIN	
56157239	56157239	1	GEAR SELECTOR	
56157271	56157271	1	COMMAND LEVER	
56157303	56157303	1	SPACER	
56157324	56157324	1	PTO LEVER	
58043176	58043176	1	SPRING	

SERIAL

CONTROLS (340-346)
Version: MC 346, MC 340

CODE REV
011A_0_25340

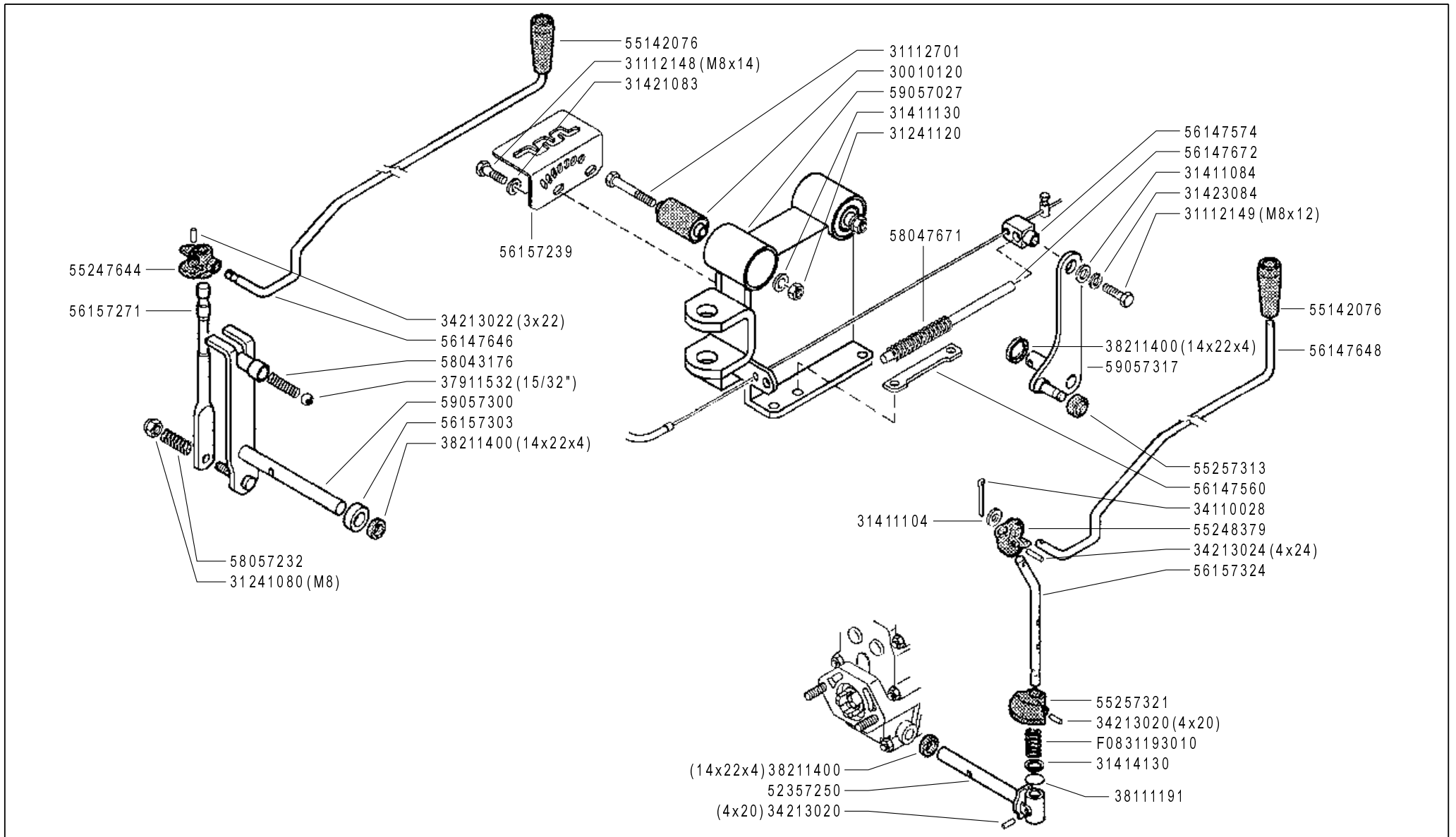

FERRARI

300 serie **95**

CONTROLS
MANDOS

COMANDI (340-346) ★

COMMANDES
ANTRIEBE

DALLA MACCHINA
DE LA MAQUINA
FROM THE MACHINE
AB DER MASCHINE

★ N.

752002 (346)

749391 (340)

11 A 0

02/2006

Rev.

ZENNE

Pos.	Code	Q.ty	Description	Notes
58047671	58047671	1	SPRING	
58057232	58057232	1	SPRING	
59057027	59057027	1	SUPPORT	
59057300	59057300	1	GEAR LEVER	
59057317	59057317	1	LEVER	
F0831193	F0831193010	1	SPRING DM.15X70	

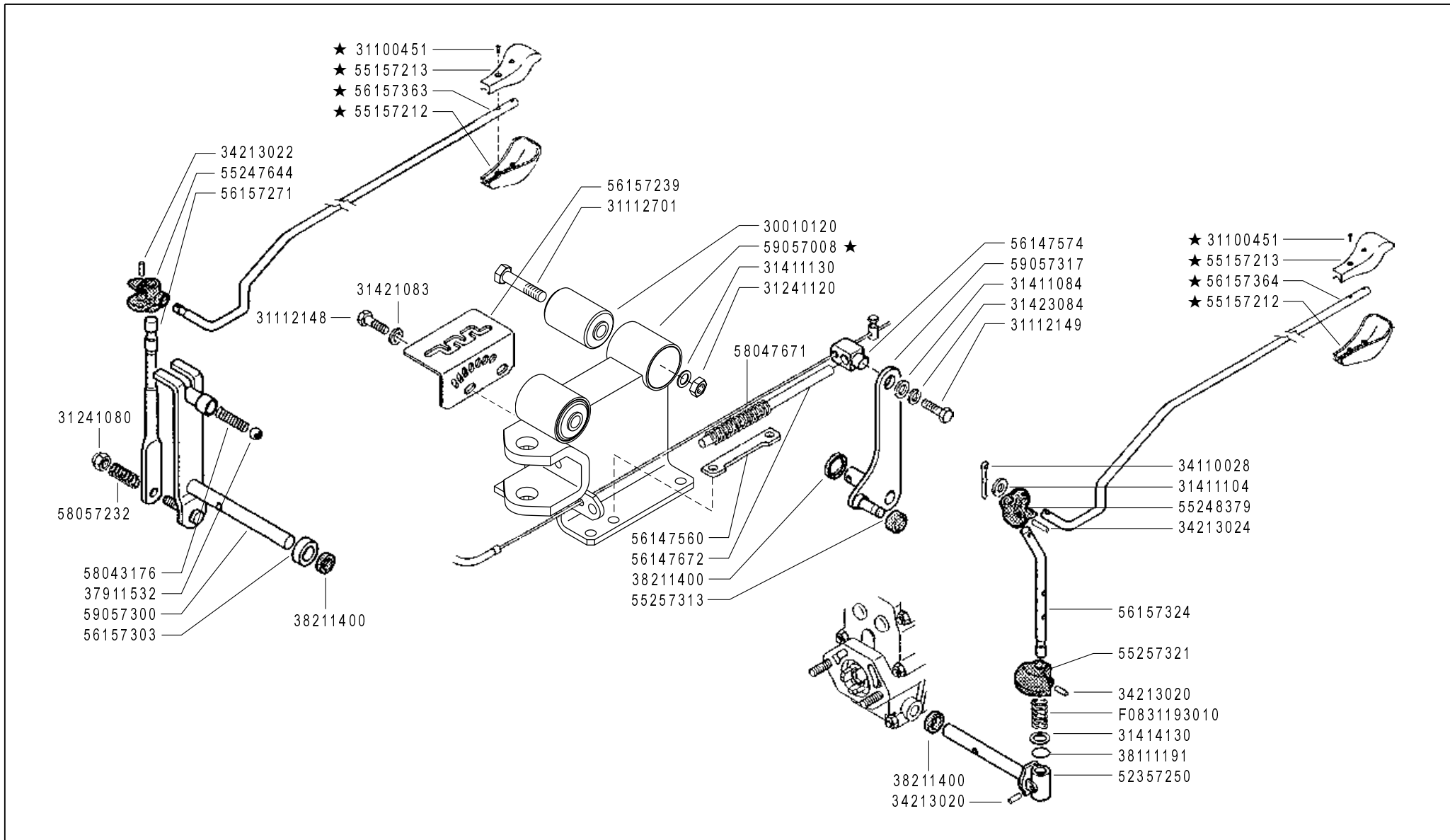

FERRARI

300 serie 95

CONTROLS
MANDOS

COMANDI (340-346)

COMMANDES
ANTRIEBE

DALLA MACCHINA
DE LA MAQUINA
FROM THE MACHINE
AB DER MASCHINE

★ N.

783462

11 A 1

01/2007

Rev.

ZENNE

Pos.	Code	Q.ty	Description	Notes
30010120	30010120	1	SILENT-BLOCK 12X40X58X66	
31100451	31100451	1	SCREW 3,5X25	
31112148	31112148	1	SCREW TE M8X18 UNI 5739 8G	
31112149	31112149	1	SCREW TE M8X12 UNI 5739 8G	
31112701	31112701	1	SCREW TE M12X100 UNI 5737	
31241080	31241080	1	SELFLOCK NUT M8	
31241120	31241120	1	SELFLOCK NUT M12	
31411084	31411084	1	WASHER 8,4x17	
31411104	31411104	1	WASHER 10,5x18	
31411130	31411130	1	WASHER 13x24	
31414130	31414130	1	WASHER 13	
31421083	31421083	1	WASHER	
31423084	31423084	1	SPRING WASHER 8,4	
34110028	34110028	1	SPLIT PIN	
34213020	34213020	1	ROLL PIN	
34213022	34213022	1	ROLL PIN	
34213024	34213024	1	ROLL PIN	
37911532	37911532	1	BALL 15/32	
38111191	38111191	1	O-RING 115 (11,91X2,62)	
38211400	38211400	1	OIL SEAL 14X22X4	
52357250	52357250	1	PIN	
55157212	55157212	1	GRIP	
55157213	55157213	1	GRIP	
55247644	55247644	1	JOINT	
55248379	55248379	1	JOINT	
55257313	55257313	1	ROLLER	
55257321	55257321	1	STOP	
56147560	56147560	1	STOP	
56147574	56147574	1	SMALL BLOCK	
56147672	56147672	1	GUIDE PIN	
56157239	56157239	1	GEAR SELECTOR	
56157271	56157271	1	COMMAND LEVER	
56157303	56157303	1	SPACER	
56157324	56157324	1	PTO LEVER	

SERIAL
START
783462

CONTROLS (340-346)

CODE REV
011A_1_32745

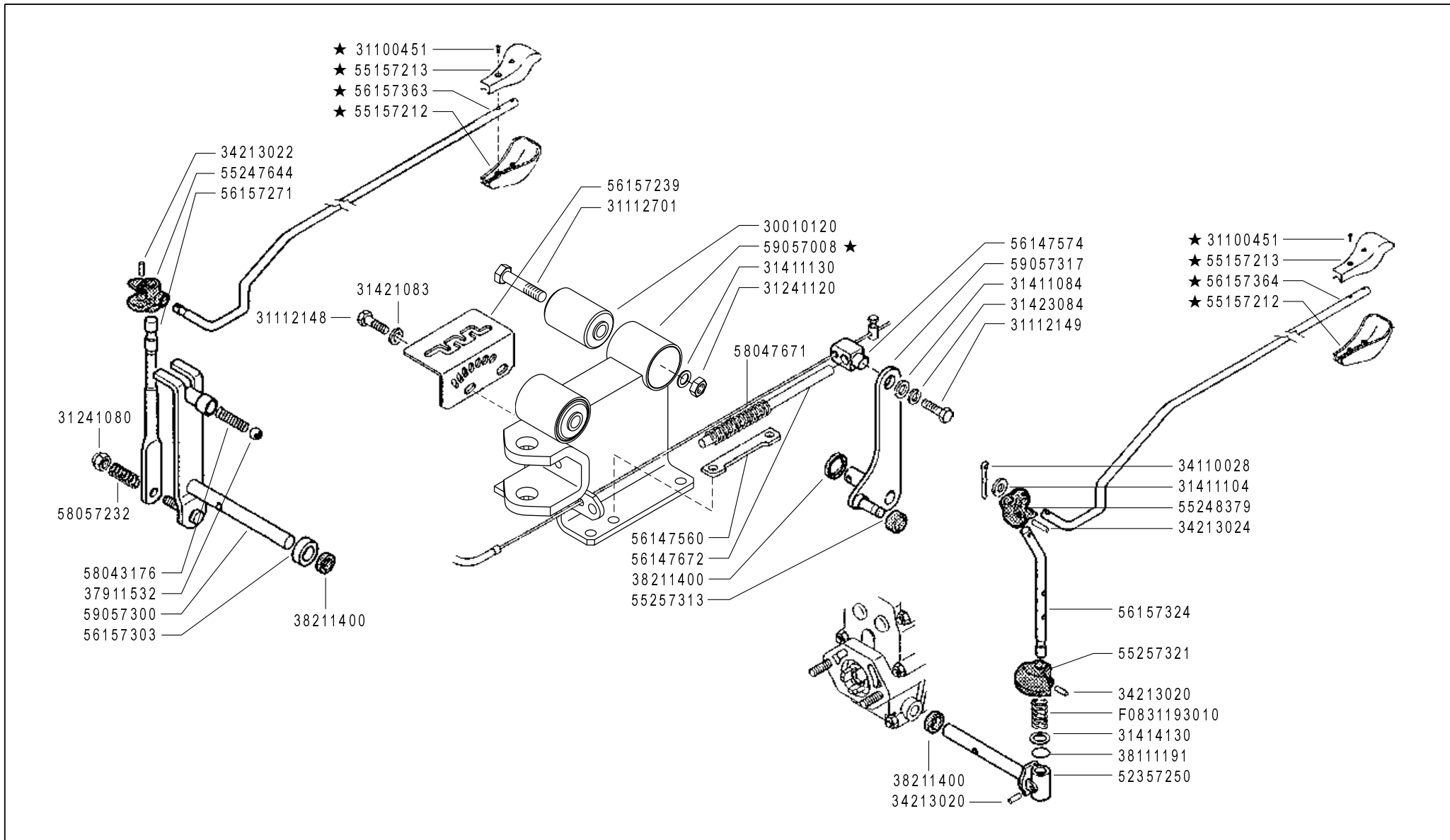

FERRARI

300 serie **95**

CONTROLS
MANDOS

COMANDI (340-346)

COMMANDES
ANTRIEBE

DALLA MACCHINA
DE LA MAQUINA
FROM THE MACHINE
AB DER MASCHINE

★ N.

783462

11 A 1

01/2007

Rev.

ZENNE

Pos.	Code	Q.ty	Description	Notes
56157363	56157363	1	PULL ROD	
56157364	56157364	1	PULL ROD	
58043176	58043176	1	SPRING	
58047671	58047671	1	SPRING	
58057232	58057232	1	SPRING	
59057008	59057008	1	SUPPORT	
59057300	59057300	1	GEAR LEVER	
59057317	59057317	1	LEVER	
F0831193	F0831193010	1	SPRING DM.15X70	

SERIAL
START
783462

CONTROLS (340-346)

CODE REV
011A_1_32745

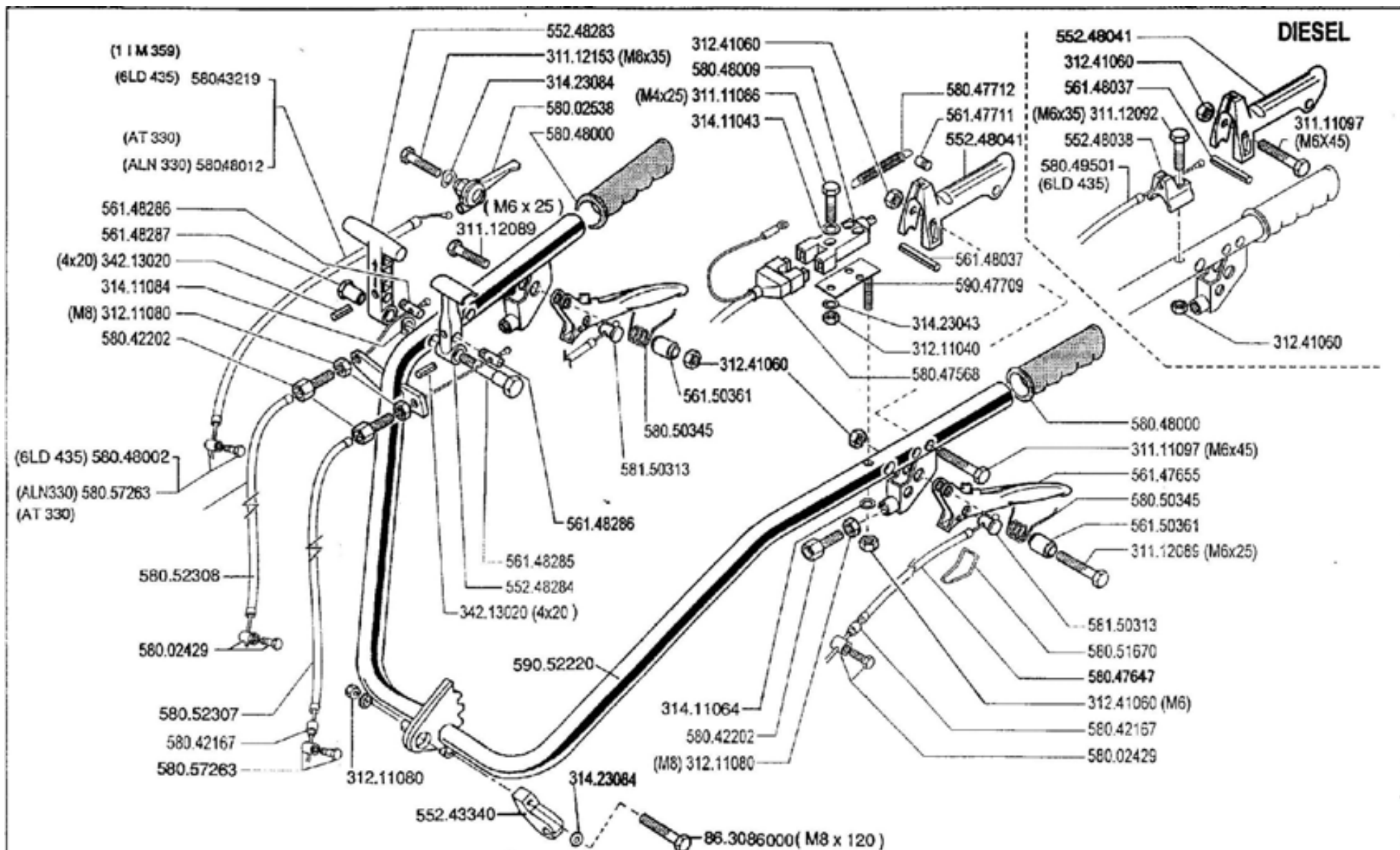

	300 serie 95	MANUBRIO (340) MANILLAR MANCHERON	HANDLEBAR LENKER	DALLA MACCHINA DE LA MAQUINA DE LA MACHINE FROM THE MACHINE AB DER MASCHINE	13.00
				N.	01.06.1995

Pos.	Code	Q.ty	Description	Notes
31111086	31111086	0	SCREW TE M4X25 UNI 5739 8G	
31111097	31111097	0	SCREW TE M6X45 UNI 5737 8G	
31112089	31112089	0	SCREW TE M6X25 UNI 5739 8G	
31112092	31112092	0	SCREW TE M6X35 UNI 5739 8G	
31112153	31112153	0	SCREW TE M8X35 UNI 5739 8G	
31211040	31211040	0	NUT M4	
31211080	31211080	0	NUT M8	
31241060	31241060	0	SELFLOCK NUT M6	
31411043	31411043	0	WASHER 4,3X9	
31411064	31411064	0	WASHER 6,4x12,5	
31411084	31411084	0	WASHER 8,4x17	
31423043	31423043	0	SPRING WASHER 4,3	
31423084	31423084	0	SPRING WASHER 8,4	
34213020	34213020	0	ROLL PIN	
55243340	55243340	0	SUPPORT	
55248038	55248038	0	STOP	
55248041	55248041	0	LEVER	
55248283	55248283	0	COMMAND LEVER	
55248284	55248284	0	LEVER	
56147655	56147655	0	CLUTCH LEVER	
56147711	56147711	0	PIN	
56148037	56148037	0	LEVER STOP	
56148285	56148285	0	PIN	
56148286	56148286	0	PIN	
56148287	56148287	0	STUD BOLT	
56150361	56150361	0	SPACER	
58002429	58002429	0	CLAMPING SCREW	
58002538	58002538	0	COMMAND LEVER	
58042167	58042167	0	SHEATH TERMINAL	
58042202	58042202	0	ADJUSTING SCREW	
58043219	58043219	0	LINE AND SHEATH	
58047568	58047568	0	WIRING	
58047647	58047647	0	LINE AND SHEATH	
58047712	58047712	0	SPRING	

SERIAL

HANDLEBAR (340)

CODE REV

013_0_11706

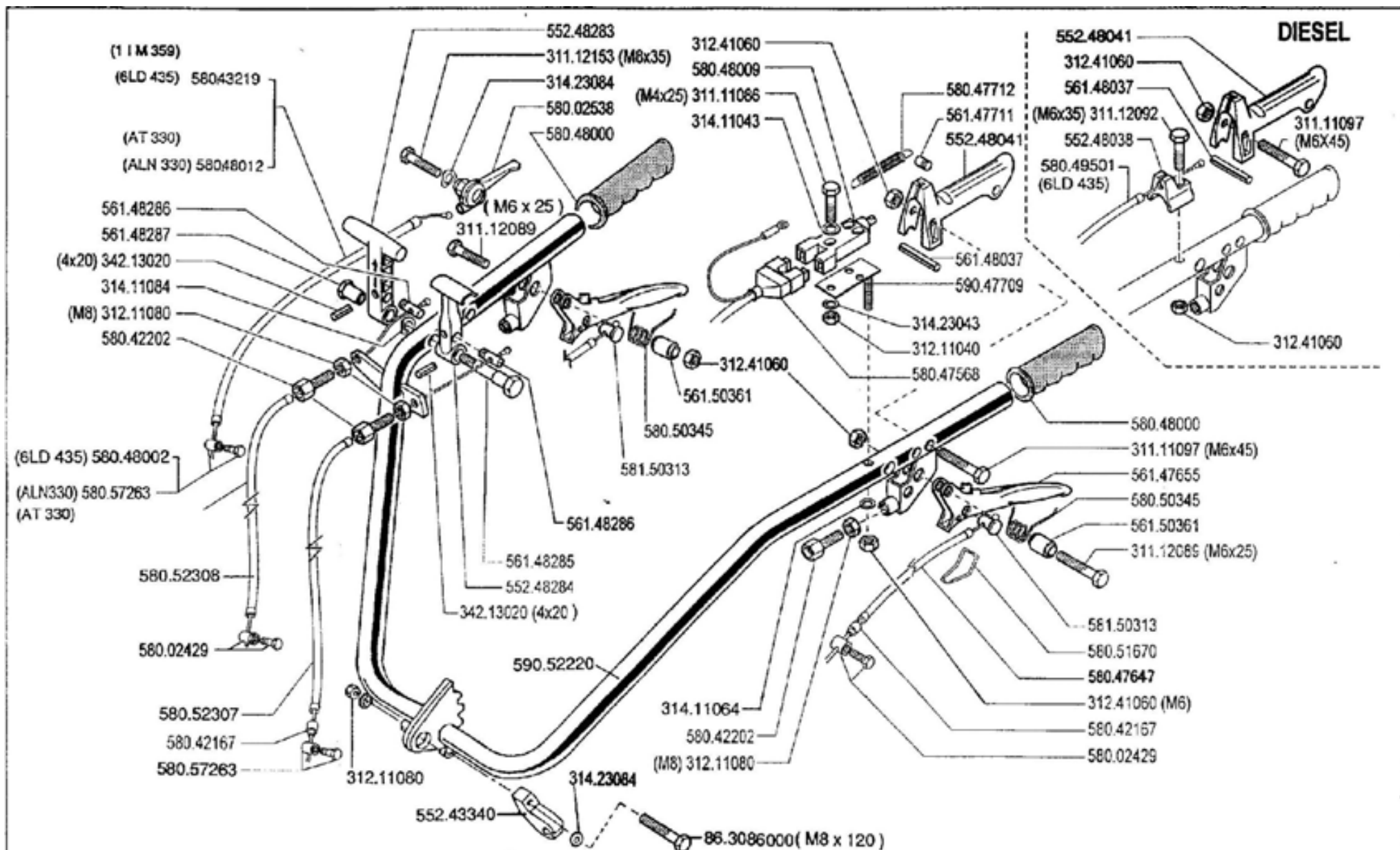

	300 serie 95	MANUBRIO (340) MANILLAR MANCHERON	HANDLEBAR LENKER	DALLA MACCHINA DE LA MAQUINA DE LA MACHINE FROM THE MACHINE AB DER MASCHINE	13.00
				N.	01.06.1995

Pos.	Code	Q.ty	Description	Notes
58048000	58048000	0	KNOB	
58048002	58048002	0	CLAMPING SCREW	
58048009	58048009	0	SWITCH	
58048012	58048012	0	LINE AND SHEATH	
58049501	58049501	0	LINE AND SHEATH	
58050345	58050345	0	SPRING	
58051670	58051670	0	CLEVIS	
58052307	58052307	0	LINE AND SHEATH	
58052308	58052308	0	LINE AND SHEATH	
58057263	58057263	0	CLAMPING SCREW	
58150313	58150313	0	CABLE CLAMP	
59047709	59047709	0	SWITCH SUPPORT	
59052220	59052220	0	COMPLETE HANDLE BAR	
F0863086	F0863086000	0	SCREW M8X120 UNI 5737	

Pos.	Code	Q.ty	Description	Notes
31111086	31111086	0	SCREW TE M4X25 UNI 5739 8G	
31111097	31111097	0	SCREW TE M6X45 UNI 5737 8G	
31112089	31112089	0	SCREW TE M6X25 UNI 5739 8G	
31112092	31112092	0	SCREW TE M6X35 UNI 5739 8G	
31112153	31112153	0	SCREW TE M8X35 UNI 5739 8G	
31211040	31211040	0	NUT M4	
31211080	31211080	0	NUT M8	
31241060	31241060	0	SELFLOCK NUT M6	
31411043	31411043	0	WASHER 4,3X9	
31411064	31411064	0	WASHER 6,4x12,5	
31411084	31411084	0	WASHER 8,4x17	
31423043	31423043	0	SPRING WASHER 4,3	
31423084	31423084	0	SPRING WASHER 8,4	
34213020	34213020	0	ROLL PIN	
55243340	55243340	0	SUPPORT	
55248038	55248038	0	STOP	
55248041	55248041	0	LEVER	
55248283	55248283	0	COMMAND LEVER	
55248284	55248284	0	LEVER	
56147655	56147655	0	CLUTCH LEVER	
56147711	56147711	0	PIN	
56148037	56148037	0	LEVER STOP	
56148285	56148285	0	PIN	
56148287	56148287	0	STUD BOLT	
56148470	56148470	0	LEVER	
56150361	56150361	0	SPACER	
56157332	56157332	0	U BOLT	
58002429	58002429	0	CLAMPING SCREW	
58002538	58002538	0	COMMAND LEVER	
58042167	58042167	0	SHEATH TERMINAL	
58042202	58042202	0	ADJUSTING SCREW	
58043216	58043216	0	LINE AND SHEATH	
58043219	58043219	0	LINE AND SHEATH	
58047568	58047568	0	WIRING	

SERIAL
START
3760

HANDLEBAR (340)

CODE REV
013_1_11755

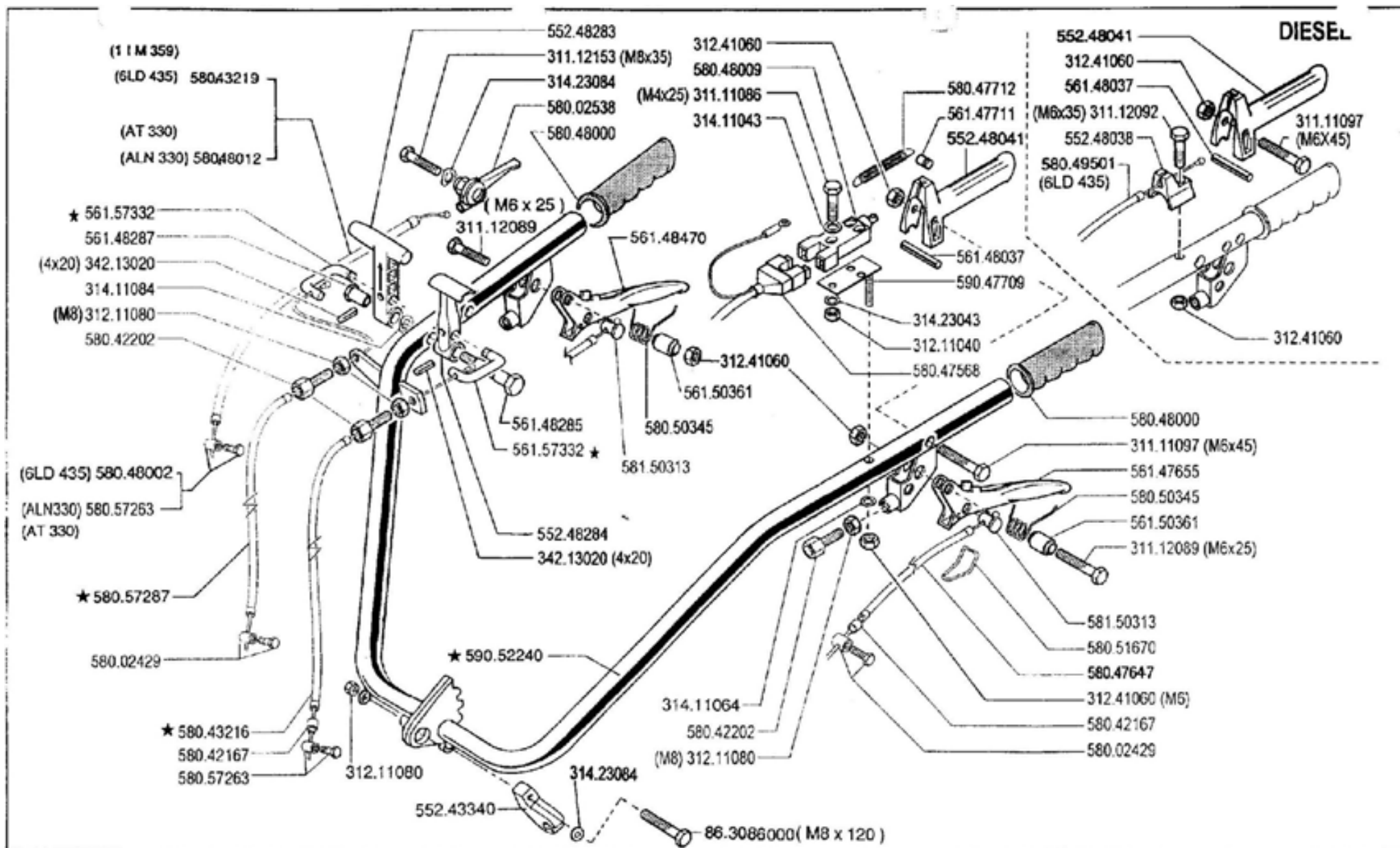

FERRARI

300 serie **95**

MANILLAR
MANCHERON

MANUBRIO (340)

HANDLEBAR
LENKER

DALLA MACCHINA
DE LA MAQUINA
DE LA MACHINE
FROM THE MACHINE
AB DER MASCHINE

★ N.

3760

13.01

11.1996

Pos.	Code	Q.ty	Description	Notes
58047647	58047647	0	LINE AND SHEATH	
58047712	58047712	0	SPRING	
58048000	58048000	0	KNOB	
58048002	58048002	0	CLAMPING SCREW	
58048009	58048009	0	SWITCH	
58048012	58048012	0	LINE AND SHEATH	
58049501	58049501	0	LINE AND SHEATH	
58050345	58050345	0	SPRING	
58051670	58051670	0	CLEVIS	
58057263	58057263	0	CLAMPING SCREW	
58057287	58057287	0	LINE AND SHEATH	
58150313	58150313	0	CABLE CLAMP	
59047709	59047709	0	SWITCH SUPPORT	
59052240	59052240	0	COMPLETE HANDLE BAR	
F0863086	F0863086000	0	SCREW M8X120 UNI 5737	

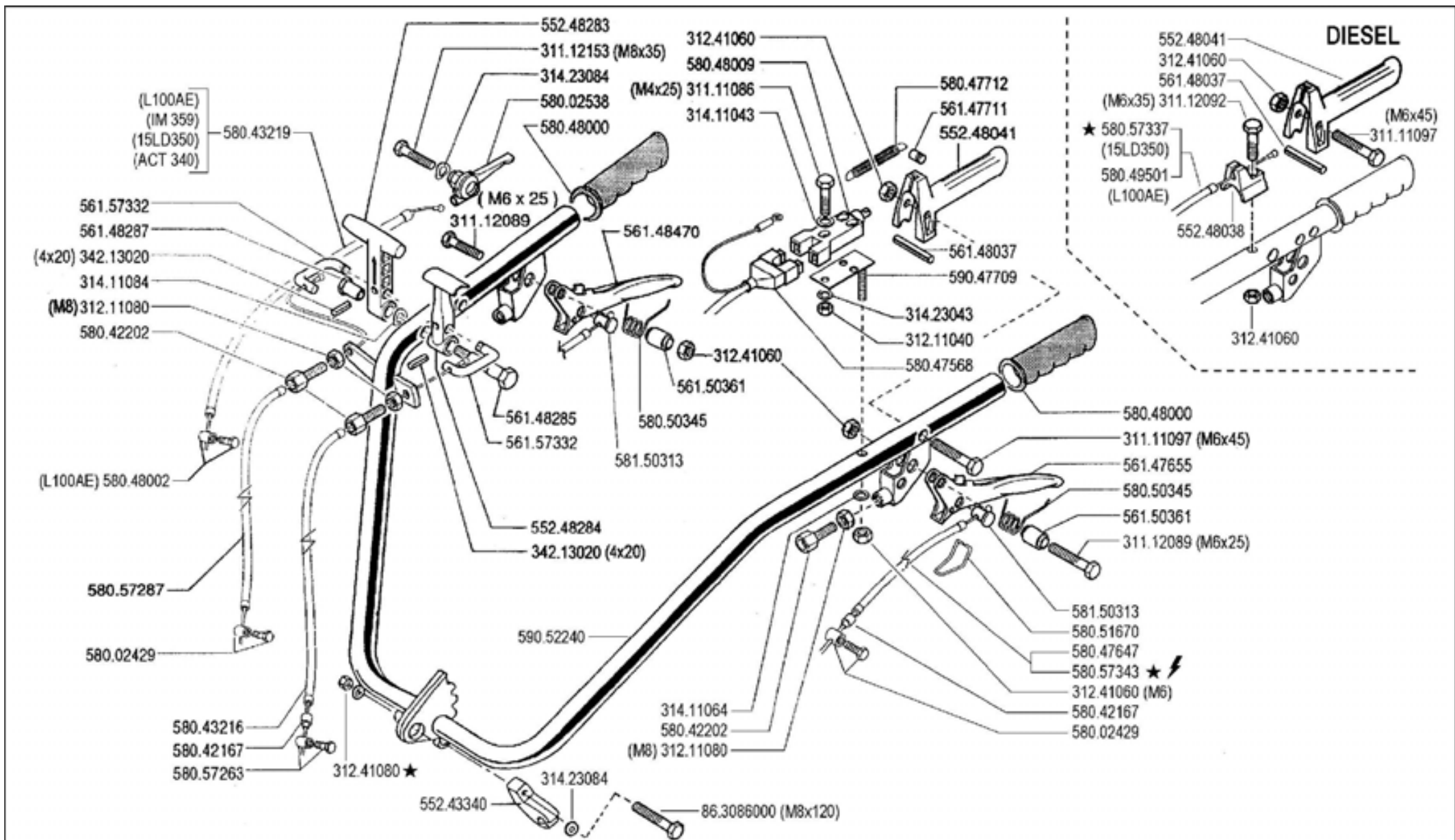

	300 serie 95	MANUBRIO (340) HANDLEBAR MANILLAR	DALLA MACCHINA DE LA MAQUINA DE LA MACHINE FROM THE MACHINE AB DER MASCHINE	AGGIORNAMENTO	13	Vol. 02
				REVISION		
				MISE A JOUR		
				APLAZAMIENTO		
				ANPASSUNG		
			★N.	1/2000		

Pos.	Code	Q.ty	Description	Notes
31111086	31111086	0	SCREW TE M4X25 UNI 5739 8G	
31111097	31111097	0	SCREW TE M6X45 UNI 5737 8G	
31112089	31112089	0	SCREW TE M6X25 UNI 5739 8G	
31112092	31112092	0	SCREW TE M6X35 UNI 5739 8G	
31112153	31112153	0	SCREW TE M8X35 UNI 5739 8G	
31211040	31211040	0	NUT M4	
31211080	31211080	0	NUT M8	
31241060	31241060	0	SELFLOCK NUT M6	
31241080	31241080	0	SELFLOCK NUT M8	
31411043	31411043	0	WASHER 4,3X9	
31411064	31411064	0	WASHER 6,4x12,5	
31411084	31411084	0	WASHER 8,4x17	
31423043	31423043	0	SPRING WASHER 4,3	
31423084	31423084	0	SPRING WASHER 8,4	
34213020	34213020	0	ROLL PIN	
55243340	55243340	0	SUPPORT	
55248038	55248038	0	STOP	
55248041	55248041	0	LEVER	
55248283	55248283	0	COMMAND LEVER	
55248284	55248284	0	LEVER	
56147655	56147655	0	CLUTCH LEVER	
56147711	56147711	0	PIN	
56148037	56148037	0	LEVER STOP	
56148285	56148285	0	PIN	
56148287	56148287	0	STUD BOLT	
56148470	56148470	0	LEVER	
56150361	56150361	0	SPACER	
56157332	56157332	0	U BOLT	
58002429	58002429	0	CLAMPING SCREW	
58002538	58002538	0	COMMAND LEVER	
58042167	58042167	0	SHEATH TERMINAL	
58042202	58042202	0	ADJUSTING SCREW	
58043216	58043216	0	LINE AND SHEATH	
58043219	58043219	0	LINE AND SHEATH	

SERIAL

HANDLEBAR (340)

CODE REV

013_2_11805

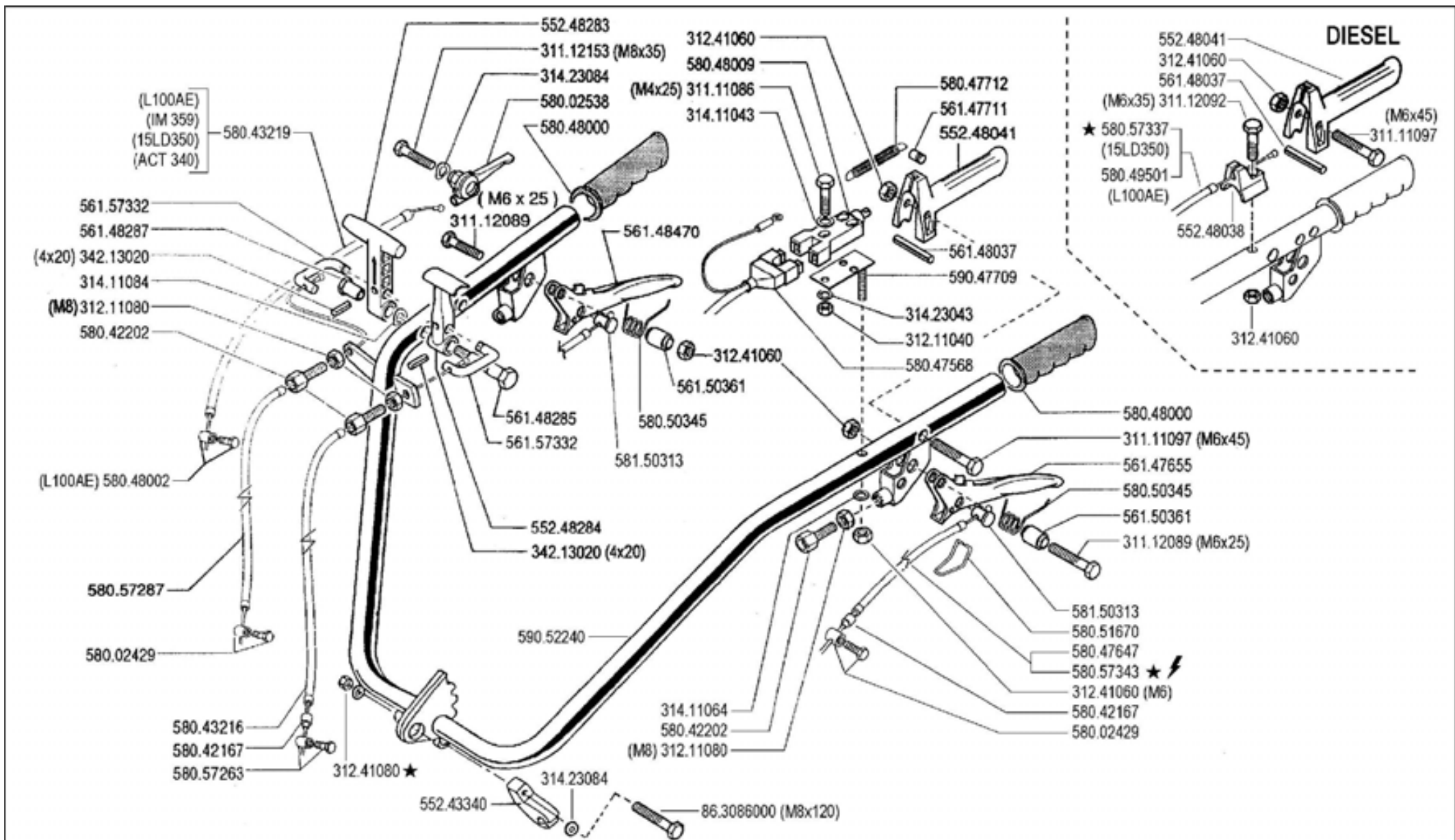

	300 serie 95	MANUBRIO (340) HANDLEBAR MANILLAR	DALLA MACCHINA DE LA MAQUINA DE LA MACHINE FROM THE MACHINE AB DER MASCHINE	AGGIORNAMENTO	13	Vol. 02
				REVISION		
				MISE A JOUR		
				APLAZAMIENTO		
				ANPASSUNG		
			★N.	1/2000		

Pos.	Code	Q.ty	Description	Notes
58047568	58047568	0	WIRING	
58047647	58047647	0	LINE AND SHEATH	
58047712	58047712	0	SPRING	
58048000	58048000	0	KNOB	
58048002	58048002	0	CLAMPING SCREW	
58048009	58048009	0	SWITCH	
58049501	58049501	0	LINE AND SHEATH	
58050345	58050345	0	SPRING	
58051670	58051670	0	CLEVIS	
58057263	58057263	0	CLAMPING SCREW	
58057287	58057287	0	LINE AND SHEATH	
58057337	58057337	0	LINE AND SHEATH	
58057343	58057343	0	LINE AND SHEATH	
58150313	58150313	0	CABLE CLAMP	
59047709	59047709	0	SWITCH SUPPORT	
59052240	59052240	0	COMPLETE HANDLE BAR	
F0863086	F0863086000	0	SCREW M8X120 UNI 5737	

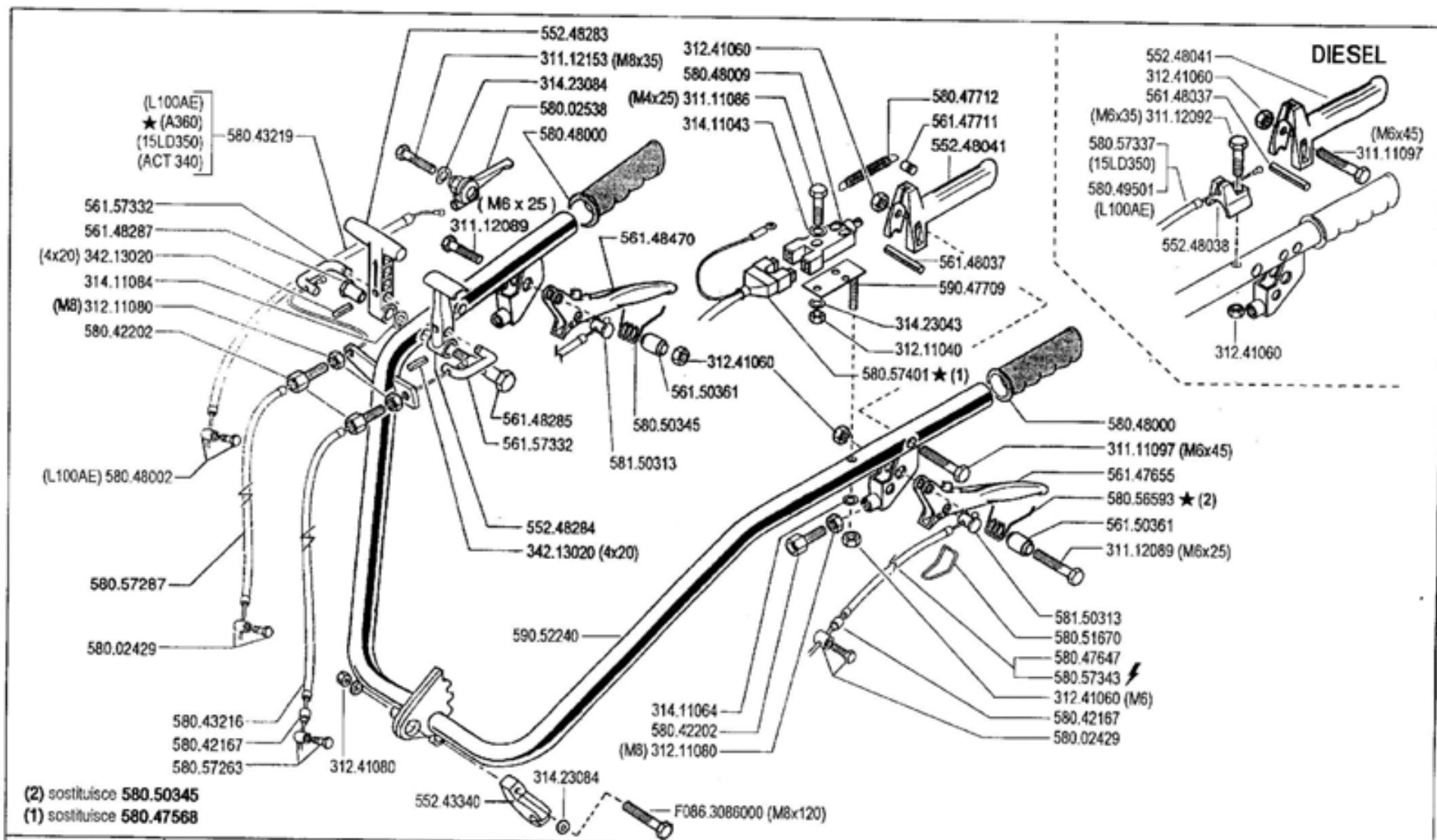

FERRARI

300 serie **95**

HANDLEBAR
MANILLAR

MANUBRIO (340)

MANCHERON
LENKER

DALLA MACCHINA
DE LA MAQUINA
DE LA MACHINE
FROM THE MACHINE
AB DER MASCHINE

AGGIORNAMENTO

REVISION

MISE A JOUR

APLIZAMENIO

ANPASSUNG

13

REV.
3

★ N.

11/2002

3000

Pos.	Code	Q.ty	Description	Notes
31111086	31111086	0	SCREW TE M4X25 UNI 5739 8G	
31111097	31111097	0	SCREW TE M6X45 UNI 5737 8G	
31112089	31112089	0	SCREW TE M6X25 UNI 5739 8G	
31112092	31112092	0	SCREW TE M6X35 UNI 5739 8G	
31112153	31112153	0	SCREW TE M8X35 UNI 5739 8G	
31211040	31211040	0	NUT M4	
31211080	31211080	0	NUT M8	
31241060	31241060	0	SELFLOCK NUT M6	
31241080	31241080	0	SELFLOCK NUT M8	
31411043	31411043	0	WASHER 4,3X9	
31411064	31411064	0	WASHER 6,4x12,5	
31411084	31411084	0	WASHER 8,4x17	
31423043	31423043	0	SPRING WASHER 4,3	
31423084	31423084	0	SPRING WASHER 8,4	
34213020	34213020	0	ROLL PIN	
55243340	55243340	0	SUPPORT	
55248038	55248038	0	STOP	
55248041	55248041	0	LEVER	
55248283	55248283	0	COMMAND LEVER	
55248284	55248284	0	LEVER	
56147655	56147655	0	CLUTCH LEVER	
56147711	56147711	0	PIN	
56148037	56148037	0	LEVER STOP	
56148285	56148285	0	PIN	
56148287	56148287	0	STUD BOLT	
56148470	56148470	0	LEVER	
56150361	56150361	0	SPACER	
56157332	56157332	0	U BOLT	
58002429	58002429	0	CLAMPING SCREW	
58002538	58002538	0	COMMAND LEVER	
58042167	58042167	0	SHEATH TERMINAL	
58042202	58042202	0	ADJUSTING SCREW	
58043216	58043216	0	LINE AND SHEATH	
58043219	58043219	0	LINE AND SHEATH	

SERIAL

HANDLEBAR (340)

CODE REV

013_3_11857

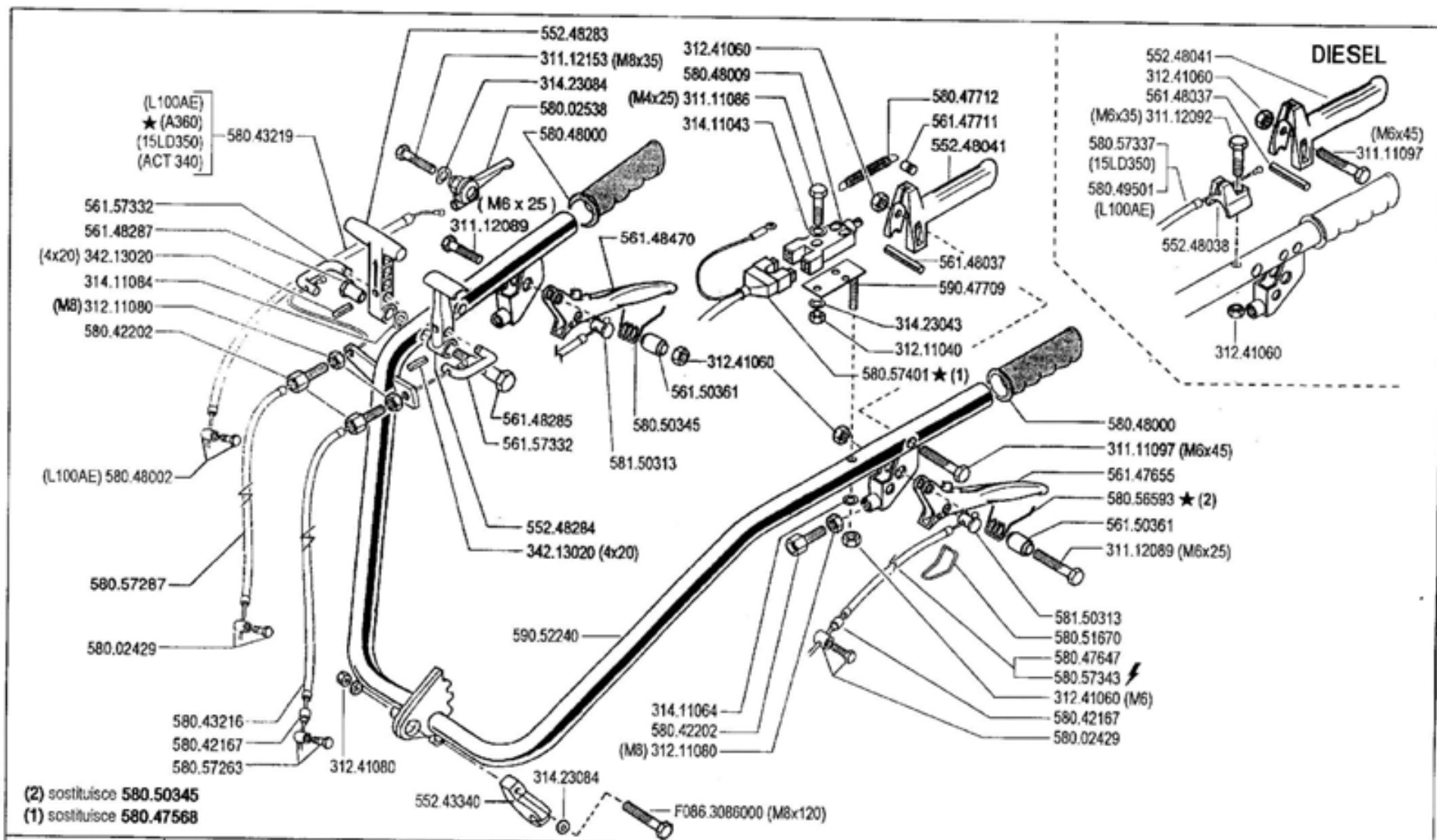

FERRARI

300 serie **95**

HANDLEBAR
MANILLAR

MANUBRIO (340)

MANCHERON
LENKER

DALLA MACCHINA
DE LA MAQUINA
DE LA MACHINE
FROM THE MACHINE
AB DER MASCHINE

AGGIORNAMENTO

REVISION

MISE A JOUR

APLIZAMENIO

ANPASSUNG

13

REV.
3

★ N.

11/2002

52000

Pos.	Code	Q.ty	Description	Notes
58047647	58047647	0	LINE AND SHEATH	
58047712	58047712	0	SPRING	
58048000	58048000	0	KNOB	
58048002	58048002	0	CLAMPING SCREW	
58048009	58048009	0	SWITCH	
58049501	58049501	0	LINE AND SHEATH	
58051670	58051670	0	CLEVIS	
58056593	58056593	0	SPRING	
58057263	58057263	0	CLAMPING SCREW	
58057287	58057287	0	LINE AND SHEATH	
58057337	58057337	0	LINE AND SHEATH	
58057343	58057343	0	LINE AND SHEATH	
58057401	58057401	0	WIRING	
58150313	58150313	0	CABLE CLAMP	
59047709	59047709	0	SWITCH SUPPORT	
59052240	59052240	0	COMPLETE HANDLE BAR	
F0863086	F0863086000	0	SCREW M8X120 UNI 5737	

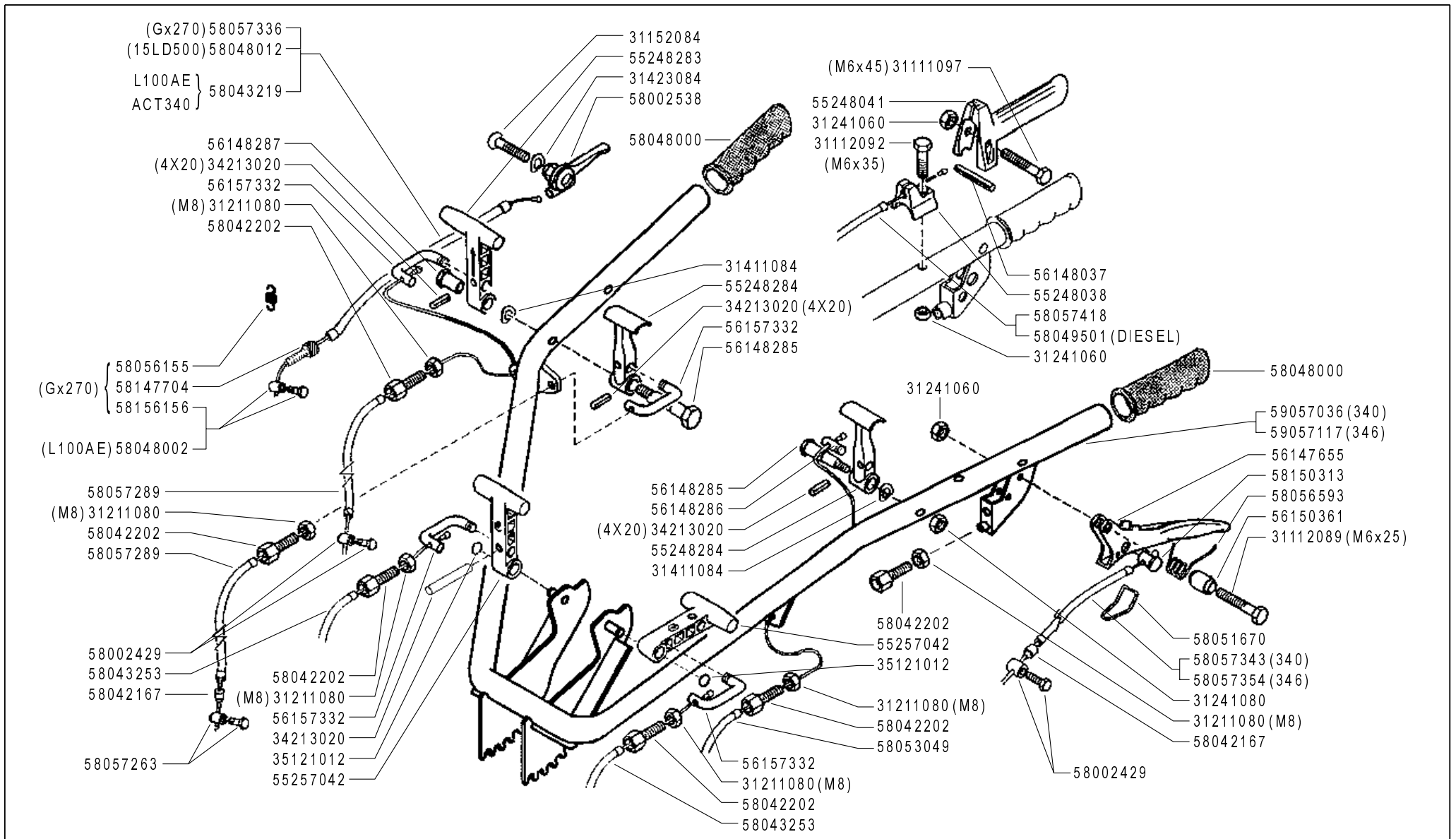

FERRARI

300 serie **95**

MANUBRIO (340-346) ★

HANDLEBAR
MANILLAR

MANCHERON
LENKER

DALLA MACCHINA
DE LA MAQUINA
DE LA MACHINE
FROM THE MACHINE
AB DER MASCHINE

★ N.

752002 (346)

749391 (340)

13

Rev.
4

02/2006

ZENNE

Pos.	Code	Q.ty	Description	Notes
31111097	31111097	1	SCREW TE M6X45 UNI 5737 8G	
31112089	31112089	1	SCREW TE M6X25 UNI 5739 8G	
31112092	31112092	1	SCREW TE M6X35 UNI 5739 8G	
31152084	31152084	1	SCREW TCEI M8X35 UNI 5931	
31211080	31211080	1	NUT M8	
31241060	31241060	1	SELFLOCK NUT M6	
31241080	31241080	1	SELFLOCK NUT M8	
31411084	31411084	1	WASHER 8,4x17	
31423084	31423084	1	SPRING WASHER 8,4	
34213020	34213020	1	ROLL PIN	
35121012	35121012	1	SEEGER RING E 12 DIN 471	
55248038	55248038	1	STOP	
55248041	55248041	1	LEVER	
55248283	55248283	1	COMMAND LEVER	
55248284	55248284	1	LEVER	
55257042	55257042	1	COMMAND LEVER	
56147655	56147655	1	CLUTCH LEVER	
56148037	56148037	1	LEVER STOP	
56148285	56148285	1	PIN	
56148286	56148286	1	PIN	
56148287	56148287	1	STUD BOLT	
56150361	56150361	1	SPACER	
56157332	56157332	1	U BOLT	
58002429	58002429	1	CLAMPING SCREW	
58002538	58002538	1	COMMAND LEVER	
58042167	58042167	1	SHEATH TERMINAL	
58042202	58042202	1	ADJUSTING SCREW	
58043219	58043219	1	LINE AND SHEATH	
58043253	58043253	1	LINE AND SHEATH	
58048000	58048000	1	KNOB	
58048002	58048002	1	CLAMPING SCREW	
58048012	58048012	1	LINE AND SHEATH	
58049501	58049501	1	LINE AND SHEATH	
58051670	58051670	1	CLEVIS	

SERIAL

HANDLEBAR (340-346)

Version: MC 340, MC 346

CODE REV

013_4_25436

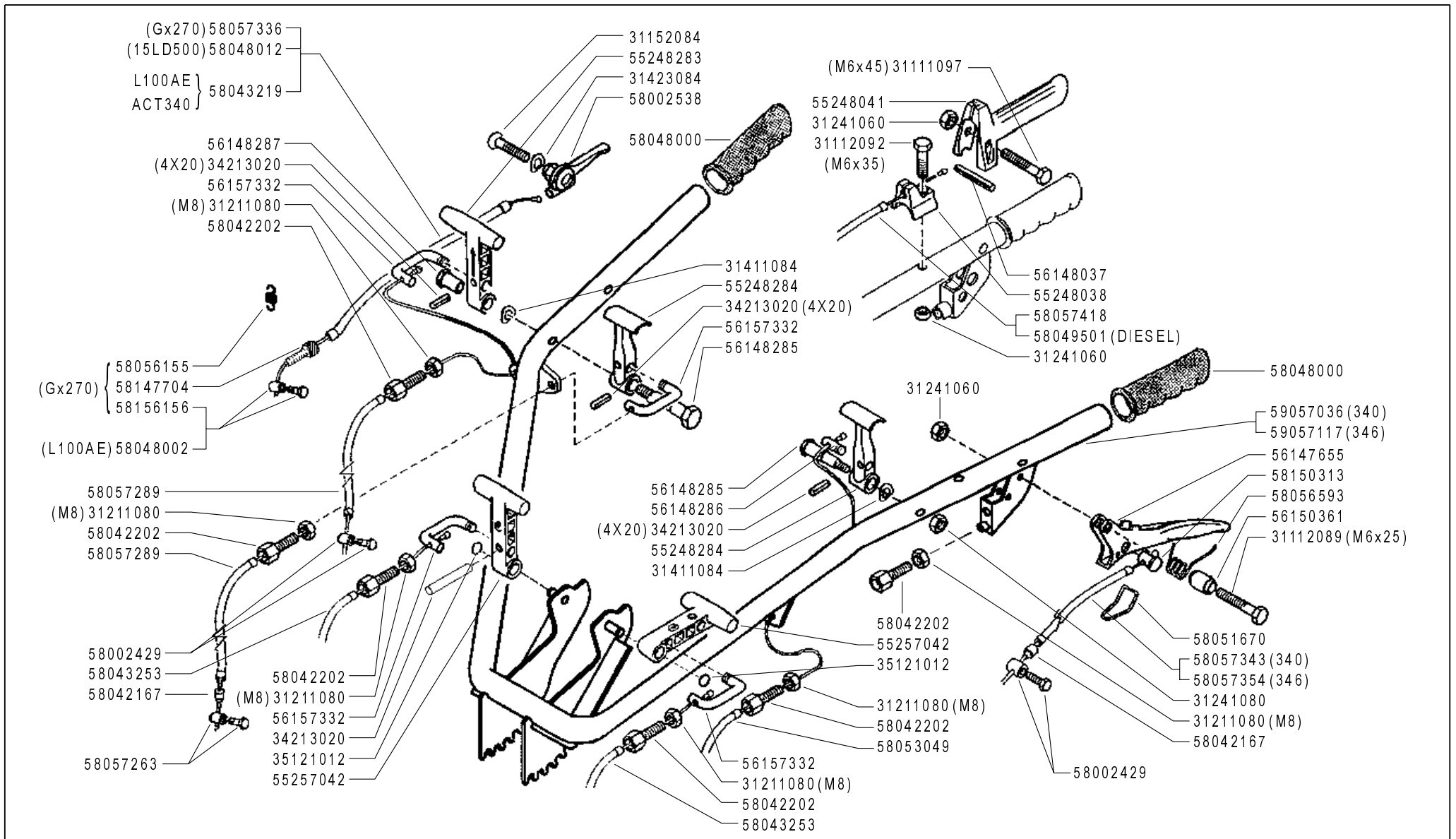

FERRARI

300 serie **95**

MANUBRIO (340-346) ★

HANDLEBAR
MANILLAR

MANCHERON
LENKER

DALLA MACCHINA
DE LA MAQUINA
DE LA MACHINE
FROM THE MACHINE
AB DER MASCHINE

★ N.

752002 (346)

749391 (340)

13

Rev.
4

02/2006

ZENNE

Pos.	Code	Q.ty	Description	Notes
58053049	58053049	1	TRANSMISSION	
58056155	58056155	1	RESTORING SPRING	Utilizzato con motore GX270
58056593	58056593	1	SPRING	
58057263	58057263	1	CLAMPING SCREW	
58057289	58057289	1	LINE AND SHEATH	
58057336	58057336	1	LINE AND SHEATH	
58057343	58057343	1	LINE AND SHEATH	
58057354	58057354	1	LINE AND SHEATH	
58057418	58057418	1	LINE AND SHEATH	
58147704	58147704	1	ADJUSTING SCREW	
58150313	58150313	1	CABLE CLAMP	
58156156	58156156	1	TERMINAL	
59057036	59057036	1	HANDLE BAR	
59057117	59057117	1	COMPLETE HANDLE BAR	

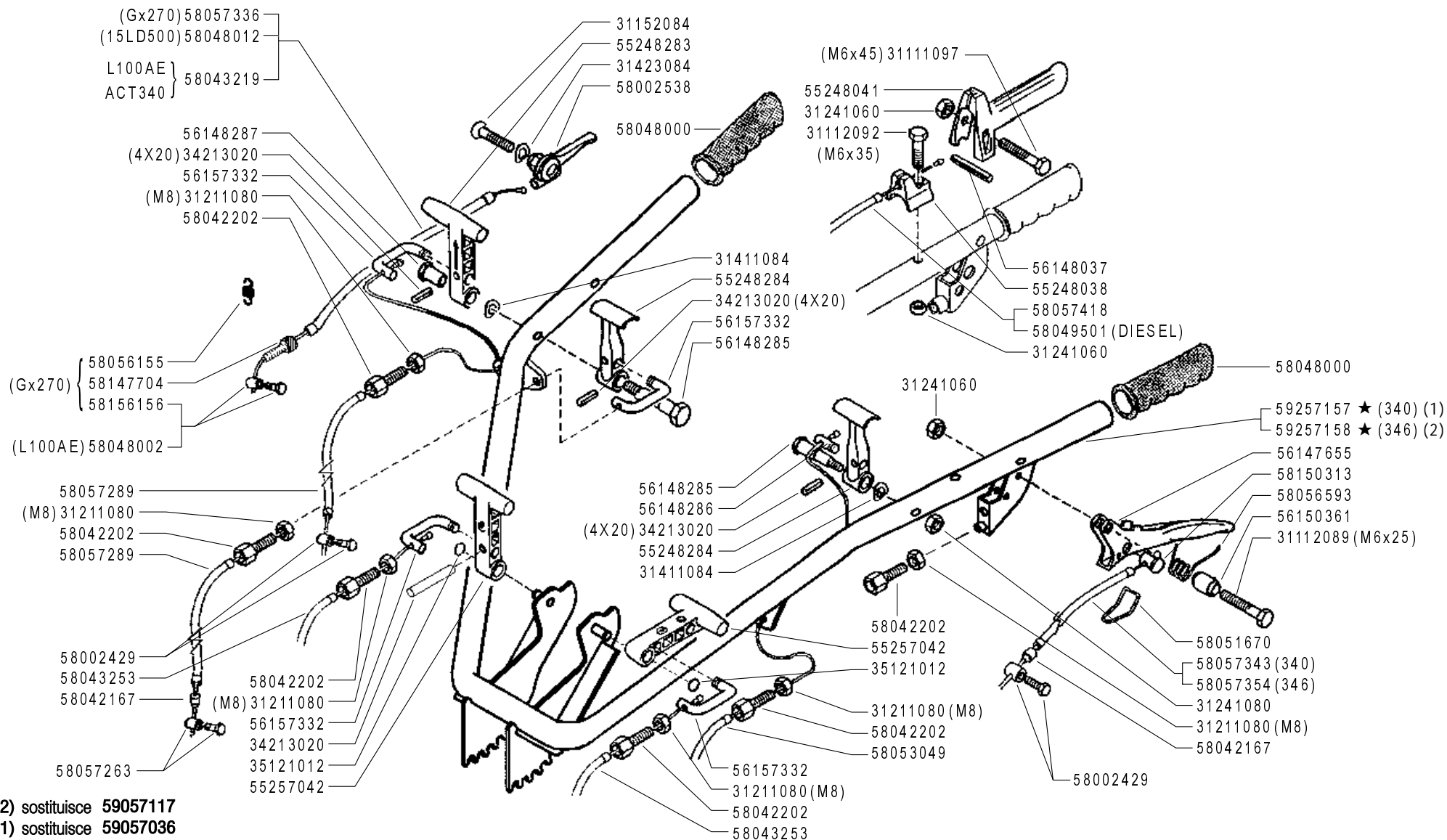

FERRARI

300 serie 95

MANUBRIO (340-346)

HANDLEBAR
MANILLAR

MANCHERON
LENKER

DALLA MACCHINA
DE LA MAQUINA
DE LA MACHINE
FROM THE MACHINE
AB DER MASCHINE

AGGIORNAMENTO
REVISION
MISE A JOUR
APLAZAMIENTO
ANPASSUNG

★ N.

Rev.	5
13	
06/2006	

ZENNE

Pos.	Code	Q.ty	Description	Notes
31111097	31111097	1	SCREW TE M6X45 UNI 5737 8G	
31112089	31112089	1	SCREW TE M6X25 UNI 5739 8G	
31112092	31112092	1	SCREW TE M6X35 UNI 5739 8G	
31152084	31152084	1	SCREW TCEI M8X35 UNI 5931	
31211080	31211080	1	NUT M8	
31241060	31241060	1	SELFLOCK NUT M6	
31241080	31241080	1	SELFLOCK NUT M8	
31411084	31411084	1	WASHER 8,4x17	
31423084	31423084	1	SPRING WASHER 8,4	
34213020	34213020	1	ROLL PIN	
35121012	35121012	1	SEEGER RING E 12 DIN 471	
55248038	55248038	1	STOP	
55248041	55248041	1	LEVER	
55248283	55248283	1	COMMAND LEVER	
55248284	55248284	1	LEVER	
55257042	55257042	1	COMMAND LEVER	
56147655	56147655	1	CLUTCH LEVER	
56148037	56148037	1	LEVER STOP	
56148285	56148285	1	PIN	
56148286	56148286	1	PIN	
56148287	56148287	1	STUD BOLT	
56150361	56150361	1	SPACER	
56157332	56157332	1	U BOLT	
58002429	58002429	1	CLAMPING SCREW	
58002538	58002538	1	COMMAND LEVER	
58042167	58042167	1	SHEATH TERMINAL	
58042202	58042202	1	ADJUSTING SCREW	
58043219	58043219	1	LINE AND SHEATH	
58043253	58043253	1	LINE AND SHEATH	
58048000	58048000	1	KNOB	
58048002	58048002	1	CLAMPING SCREW	
58048012	58048012	1	LINE AND SHEATH	
58049501	58049501	1	LINE AND SHEATH	
58051670	58051670	1	CLEVIS	

SERIAL

HANDLEBAR (340-346)

CODE REV

013_5_32888

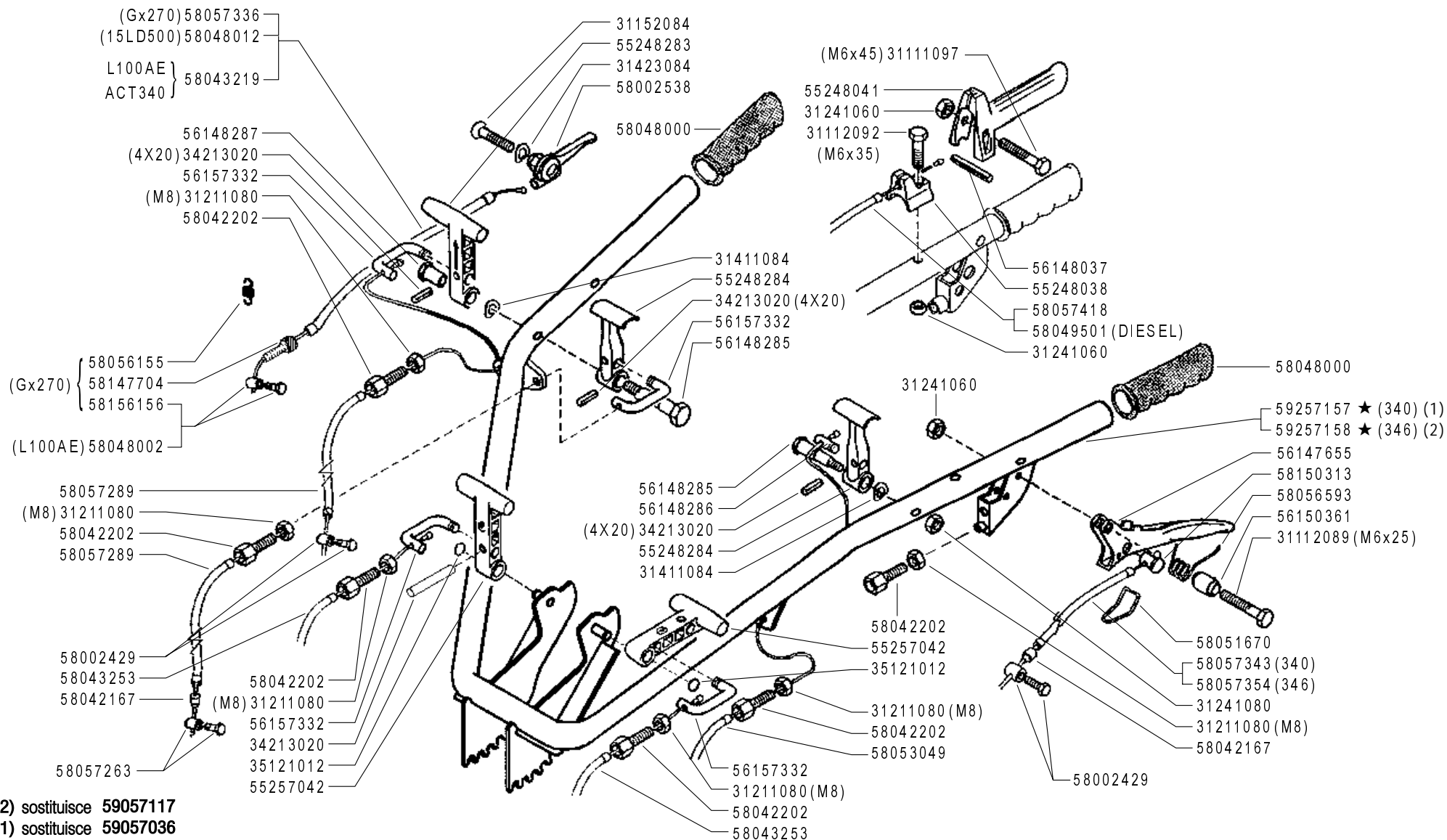

FERRARI

300 serie 95

MANUBRIO (340-346)

HANDLEBAR
MANILLAR

MANCHERON
LENKER

DALLA MACCHINA
DE LA MAQUINA
DE LA MACHINE
FROM THE MACHINE
AB DER MASCHINE

AGGIORNAMENTO
REVISION
MISE A JOUR
APLAZAMIENTO
ANPASSUNG

★ N.

13

Rev.
5

06/2006

ZENNE

Pos.	Code	Q.ty	Description	Notes
58053049	58053049	1	TRANSMISSION	
58056155	58056155	1	RESTORING SPRING	Utilizzato con motore GX270
58056593	58056593	1	SPRING	
58057263	58057263	1	CLAMPING SCREW	
58057289	58057289	1	LINE AND SHEATH	
58057336	58057336	1	LINE AND SHEATH	
58057343	58057343	1	LINE AND SHEATH	
58057354	58057354	1	LINE AND SHEATH	
58057418	58057418	1	LINE AND SHEATH	
58147704	58147704	1	ADJUSTING SCREW	
58150313	58150313	1	CABLE CLAMP	
58156156	58156156	1	TERMINAL	
59257157	59257157	1	HANDLE BAR	
59257158	59257158	1	HANDLE BAR	

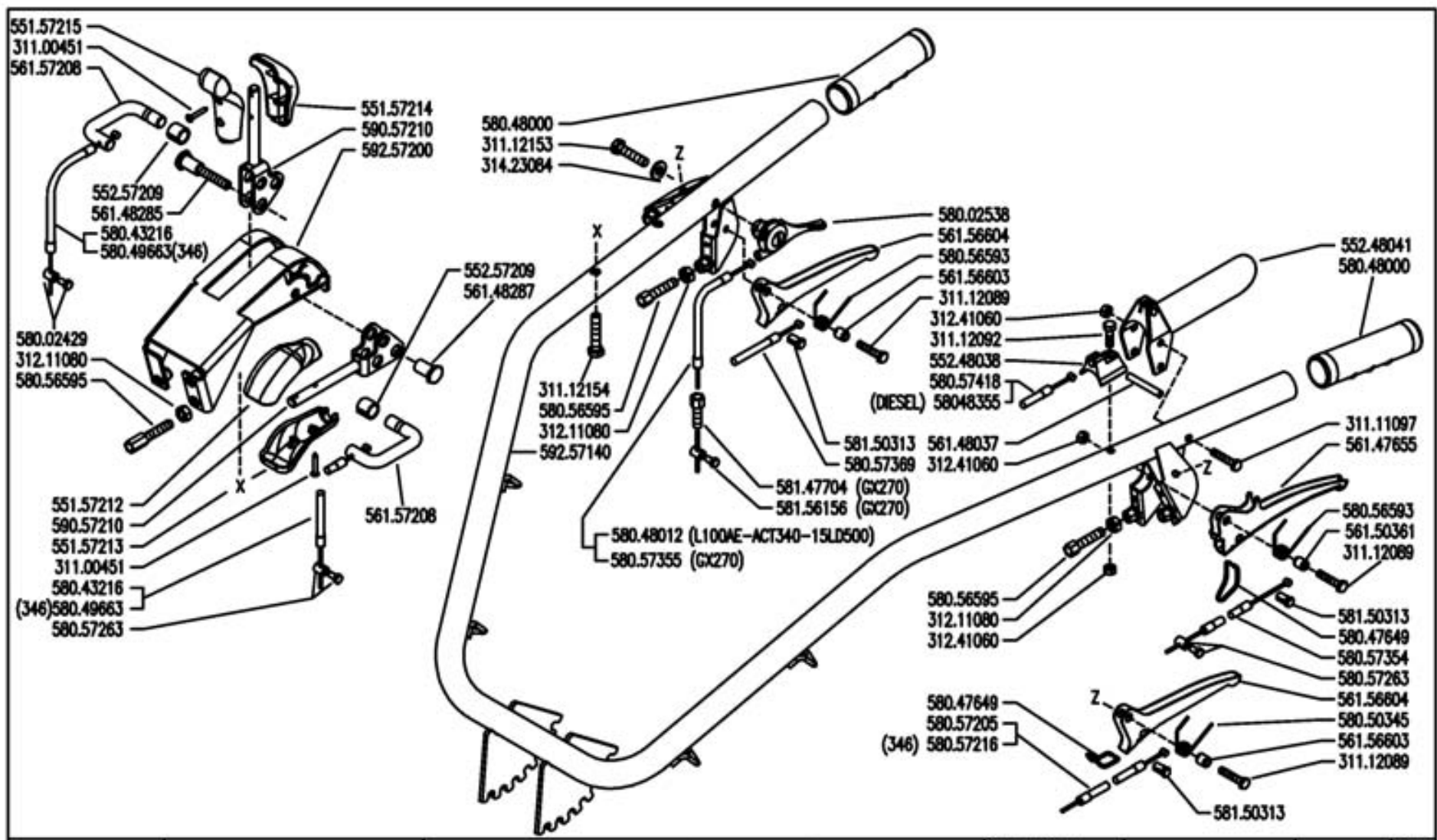

	300 serie 95	MANUBRIO (340-346)★		DALLA MACCHINA DE LA MAQUINA FROM THE MACHINE AB DER MASCHINE	<table border="1"> <tr> <td>Rev.</td> <td>13</td> <td>6</td> </tr> <tr> <td>★ N.</td> <td>783462</td> <td>01/2007</td> </tr> </table>	Rev.	13	6	★ N.	783462	01/2007
		Rev.	13			6					
★ N.	783462	01/2007									
HANDLEBAR MANILLAR	MANCHERON LENKER										

Pos.	Code	Q.ty	Description	Notes
31100451	31100451	1	SCREW 3,5X25	
31111097	31111097	1	SCREW TE M6X45 UNI 5737 8G	
31112089	31112089	1	SCREW TE M6X25 UNI 5739 8G	
31112092	31112092	1	SCREW TE M6X35 UNI 5739 8G	
31112153	31112153	1	SCREW TE M8X35 UNI 5739 8G	
31112154	31112154	1	SCREW TE M8X40 UNI 5739 8G	
31211080	31211080	1	NUT M8	
31241060	31241060	1	SELFLOCK NUT M6	
31423084	31423084	1	SPRING WASHER 8,4	
55157212	55157212	1	GRIP	
55157213	55157213	1	GRIP	
55157214	55157214	1	GRIP	
55157215	55157215	1	GRIP	
55248038	55248038	1	STOP	
55248041	55248041	1	LEVER	
55257209	55257209	1	BUSHING	
56147655	56147655	1	CLUTCH LEVER	
56148037	56148037	1	LEVER STOP	
56148285	56148285	1	PIN	
56148287	56148287	1	STUD BOLT	
56150361	56150361	1	SPACER	
56156603	56156603	1	SPACER	
56156604	56156604	1	CLUTCH LEVER	
56157208	56157208	1	U BOLT	
58002429	58002429	1	CLAMPING SCREW	
58002538	58002538	1	COMMAND LEVER	
58043216	58043216	1	LINE AND SHEATH	
58047649	58047649	1	CLEVIS	
58048000	58048000	1	KNOB	
58048012	58048012	1	LINE AND SHEATH	
58048355	58048355	1	LINE AND SHEATH	
58049663	58049663	1	LINE AND SHEATH	
58050345	58050345	1	SPRING	
58056593	58056593	1	SPRING	

SERIAL
START
783462

END
817450

HANDLEBAR (340-346)

CODE REV
013_6_33211

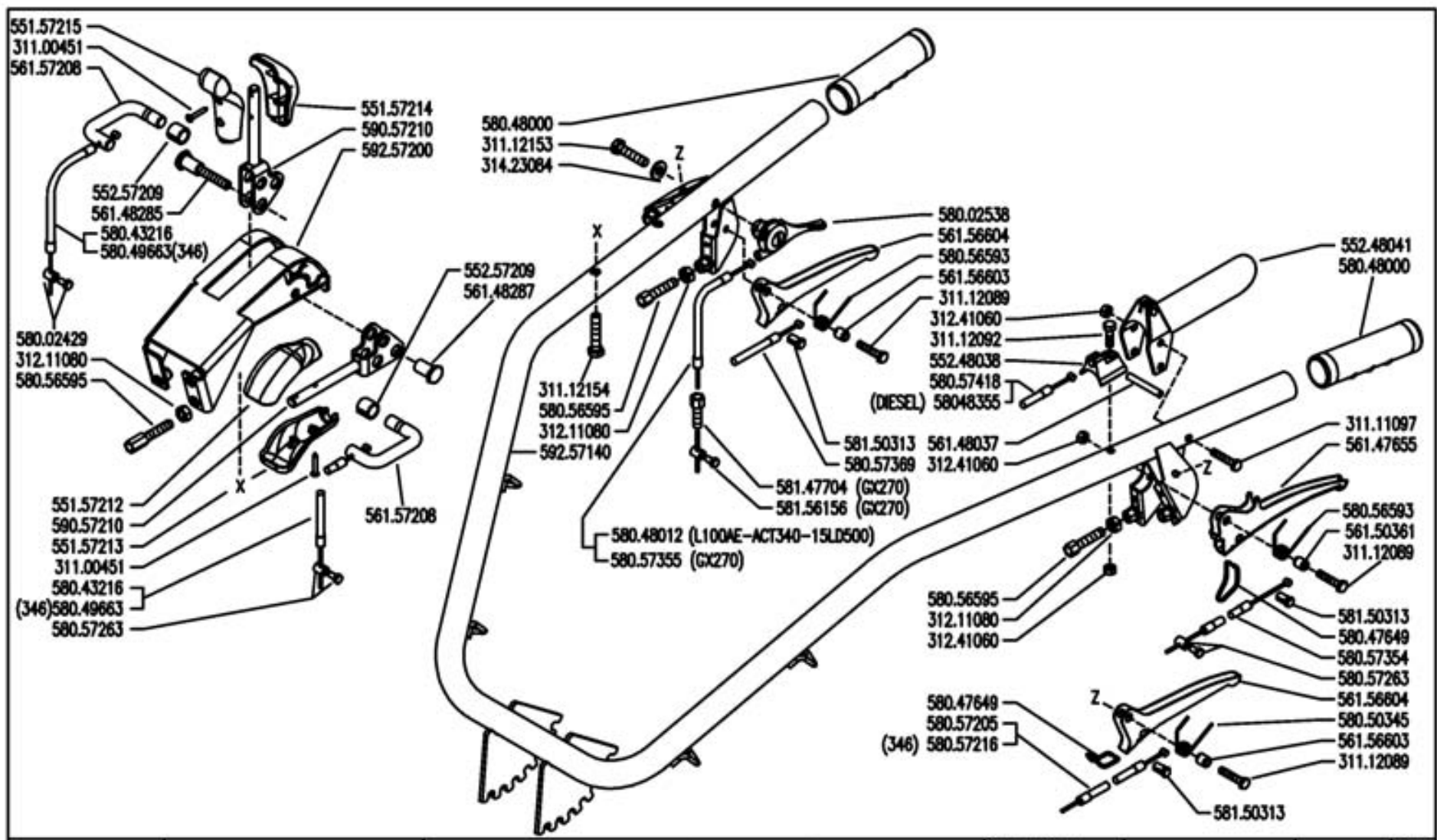

300 serie 95

MANUBRIO (340-346)★

HANDLEBAR
MANILLAR

MANCHERON
LENKER

DALLA MACCHINA
DE LA MAQUINA
FROM THE MACHINE
AB DER MASCHINE

★ N.

783462

13

Rev.
6

01/2007

IME

Pos.	Code	Q.ty	Description	Notes
58056595	58056595	1	ADJUSTING SCREW	
58057205	58057205	1	LINE AND SHEATH	
58057216	58057216	1	LINE AND SHEATH	
58057263	58057263	1	CLAMPING SCREW	
58057354	58057354	1	LINE AND SHEATH	
58057355	58057355	1	LINE AND SHEATH	
58057369	58057369	1	TRANSMISSION	
58057418	58057418	1	LINE AND SHEATH	
58147704	58147704	1	ADJUSTING SCREW	
58150313	58150313	1	CABLE CLAMP	
58156156	58156156	1	TERMINAL	
59057210	59057210	1	COMMAND LEVER	
59257140	59257140	1	COMPLETE HANDLE BAR	
59257200	59257200	1	SUPPORT	

SERIAL
START
783462

END
817450

HANDLEBAR (340-346)

CODE REV
013_6_33211

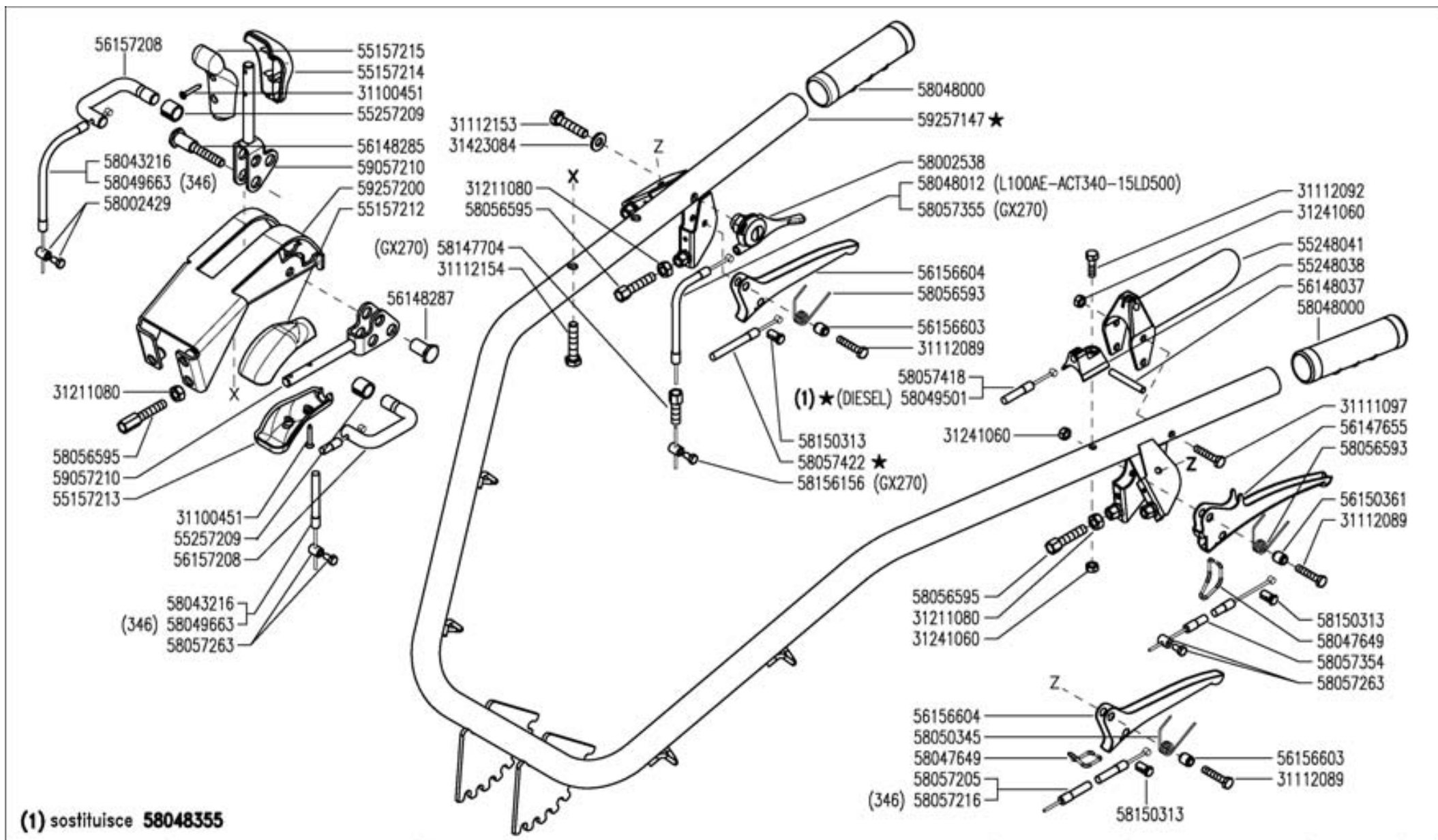

(1) sostituisce **58048355**

FERRARI

300 serie 95

MANUBRIO (340 - 346)

HANDLEBAR
MANILLAR

MANCHERON
LENKER

DALLA MACCHINA
DE LA MAQUINA
DE LA MACHINE
FROM THE MACHINE
AB DER MASCHINE

★ N.

817451

13

Rev.
7

06/2008

ZFINF

Pos.	Code	Q.ty	Description	Notes
31100451	31100451	1	SCREW 3,5X25	
31111097	31111097	1	SCREW TE M6X45 UNI 5737 8G	
31112089	31112089	1	SCREW TE M6X25 UNI 5739 8G	
31112092	31112092	1	SCREW TE M6X35 UNI 5739 8G	
31112153	31112153	1	SCREW TE M8X35 UNI 5739 8G	
31112154	31112154	1	SCREW TE M8X40 UNI 5739 8G	
31211080	31211080	1	NUT M8	
31241060	31241060	1	SELFLOCK NUT M6	
31423084	31423084	1	SPRING WASHER 8,4	
55157212	55157212	1	GRIP	
55157213	55157213	1	GRIP	
55157214	55157214	1	GRIP	
55157215	55157215	1	GRIP	
55248038	55248038	1	STOP	
55248041	55248041	1	LEVER	
55257209	55257209	1	BUSHING	
56147655	56147655	1	CLUTCH LEVER	
56148037	56148037	1	LEVER STOP	
56148285	56148285	1	PIN	
56148287	56148287	1	STUD BOLT	
56150361	56150361	1	SPACER	
56156603	56156603	1	SPACER	
56156604	56156604	1	CLUTCH LEVER	
56157208	56157208	1	U BOLT	
58002429	58002429	1	CLAMPING SCREW	
58002538	58002538	1	COMMAND LEVER	
58043216	58043216	1	LINE AND SHEATH	
58047649	58047649	1	CLEVIS	
58048000	58048000	1	KNOB	
58048012	58048012	1	LINE AND SHEATH	
58049501	58049501	1	LINE AND SHEATH	
58049663	58049663	1	LINE AND SHEATH	
58050345	58050345	1	SPRING	
58056593	58056593	1	SPRING	

SERIAL
START
817451

HANDLEBAR (340-346)

CODE REV
013_7_64065

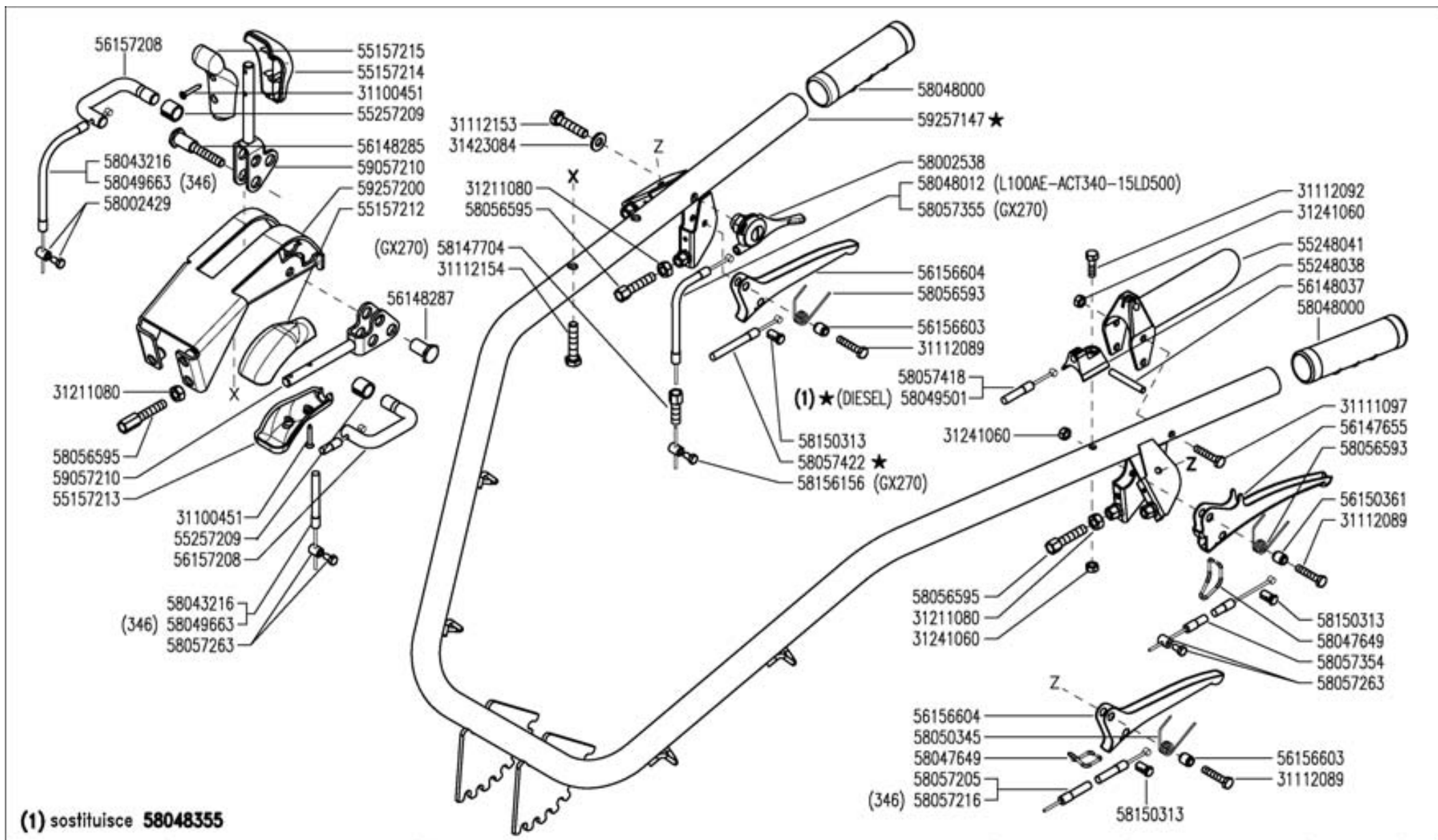

(1) sostituisce **58048355**

FERRARI	300	serie 95

MANUBRIO (340 - 346)

HANDLEBAR
MANILLAR

MANCHERON
LENKER

DALLA MACCHINA
DE LA MAQUINA
DE LA MACHINE
FROM THE MACHINE
AB DER MASCHINE

★ N.

817451

13	Rev. 7
06/2008	

ZFNF

Pos.	Code	Q.ty	Description	Notes
58056595	58056595	1	ADJUSTING SCREW	
58057205	58057205	1	LINE AND SHEATH	
58057216	58057216	1	LINE AND SHEATH	
58057263	58057263	1	CLAMPING SCREW	
58057354	58057354	1	LINE AND SHEATH	
58057355	58057355	1	LINE AND SHEATH	
58057418	58057418	1	LINE AND SHEATH	
58057422	58057422	1	TRASM.SBLOCC.PIANTONE MC740/08	
58147704	58147704	1	ADJUSTING SCREW	
58150313	58150313	1	CABLE CLAMP	
58156156	58156156	1	TERMINAL	
59057210	59057210	1	COMMAND LEVER	
59257147	59257147	1	HANDLE BAR	
59257200	59257200	1	SUPPORT	

SERIAL
START
817451

HANDLEBAR (340-346)

CODE REV
013_7_64065

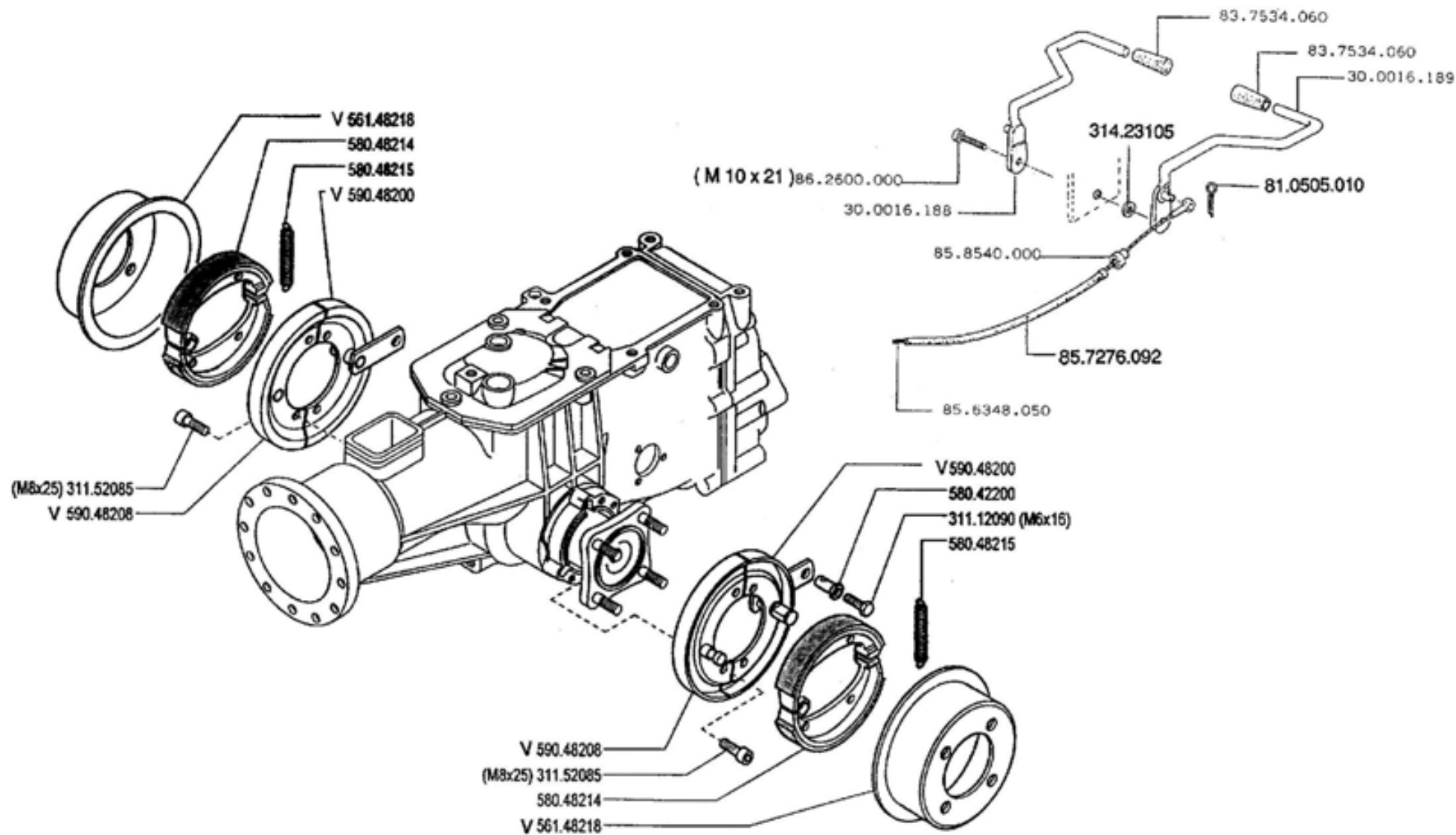

V = verde - green - vert - grün

FERRARI

300 serie 95

FRENI (340)

BRAKES
FRENOS

FREINS
BREMSEN

DALLA MACCHINA
DE LA MAGINA
DE LA MACHINE
FROM THE MACHINE
AB DER MASCHINE

N.

14 00

6/1995

Vid

ZENIT

Pos.	Code	Q.ty	Description	Notes
31112090	31112090	0	SCREW TE M6X16 UNI 5739 8G	
31152085	31152085	0	SCREW TCEI M8X25 UNI 5931	
31423105	31423105	0	SPRING WASHER 10,5	
56148218	56148218	0	BRAKE DRUM	
58042200	58042200	0	CLAMPING SCREW	
58048214	58048214	0	BRAKE BLOCK	
58048215	58048215	0	SPRING	
59048200	59048200	0	HALF DISC	
59048208	59048208	0	HALF DISC	
F0300016	F0300016188	0	BRAKE LEVER	
F0300016	F0300016189	0	BRAKE LEVER	
F0810505	F0810505010	0	SPLIT PIN A2,0X201336	
F0837534	F0837534060	0	GRIP	
F0856348	F0856348050	0	LINE	
F0857276	F0857276092	0	SHEATH	
F0858540	F0858540000	0	BUSHING	
F0862600	F0862600000	0	SPECIAL SCREW M10X21	

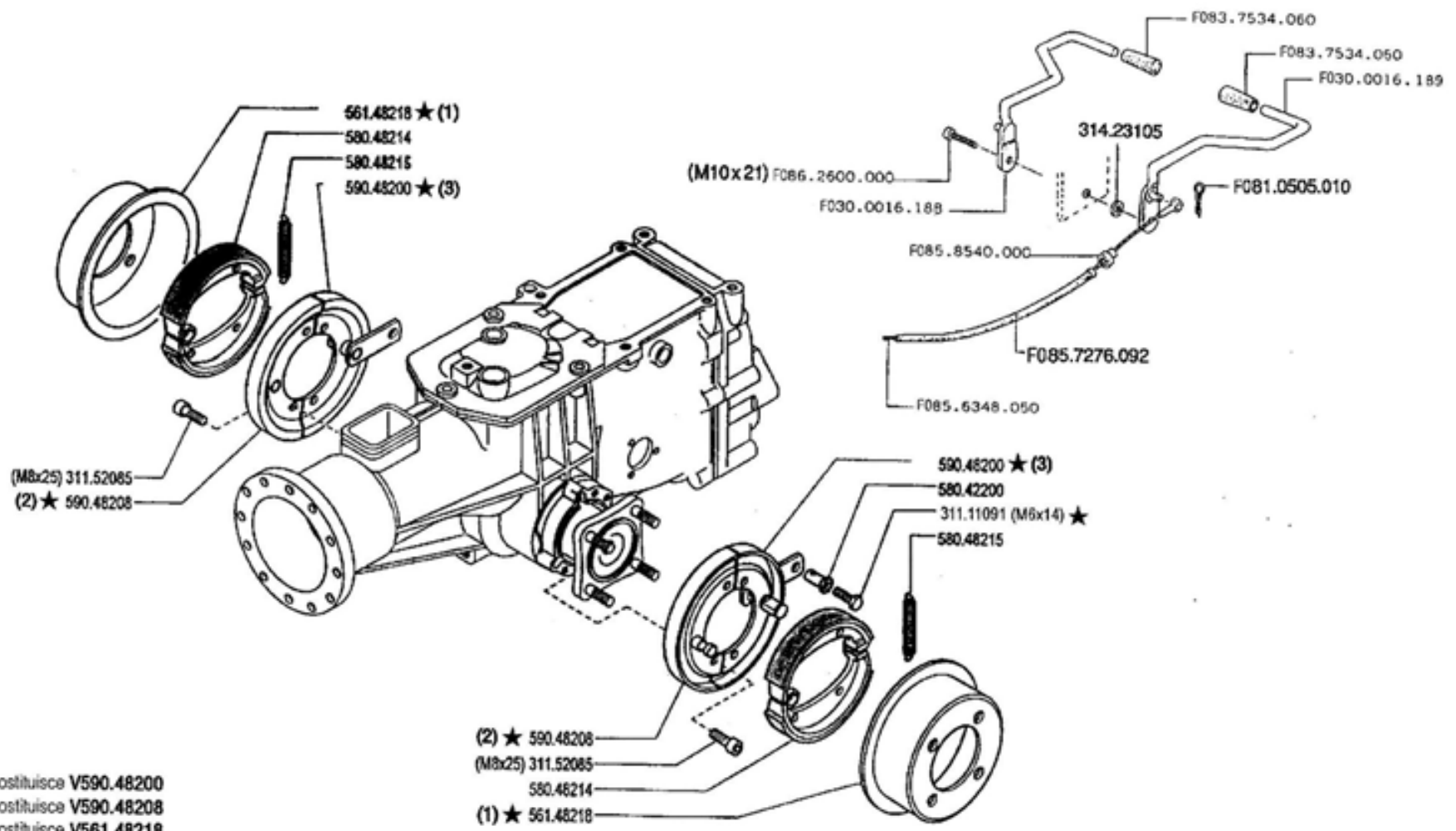

(3) sostituisce V590.48200
 (2) sostituisce V590.48208
 (1) sostituisce V561.48218

(2) ★ 590.48208
 (M8x25) 311.52085
 580.48214
 (1) ★ 561.48218

590.48200 ★ (3)
 580.42200
 311.11091 (M6x14) ★
 580.48215

FERRARI	300 serie 95	FRENI (340)		DALLA MACCHINA DE LA MAQUINA DE LA MACHINE FROM THE MACHINE AB DER MASCHINE ★N	AGGIORNAMENTO	14	Rev. 1
		BRAKES FRENOS	FREINS BREMSEN		REVISION		
					ANPASSUNG	6/2000	

Pos.	Code	Q.ty	Description	Notes
31111091	31111091	0	SCREW E M6X14 UNI 5739 8G	
31152085	31152085	0	SCREW TCEI M8X25 UNI 5931	
31423105	31423105	0	SPRING WASHER 10,5	
56148218	56148218	0	BRAKE DRUM	
58042200	58042200	0	CLAMPING SCREW	
58048214	58048214	0	BRAKE BLOCK	
58048215	58048215	0	SPRING	
59048200	59048200	0	HALF DISC	
59048208	59048208	0	HALF DISC	
F0300016	F0300016188	0	BRAKE LEVER	
F0300016	F0300016189	0	BRAKE LEVER	
F0810505	F0810505010	0	SPLIT PIN A2,0X201336	
F0837534	F0837534060	0	GRIP	
F0856348	F0856348050	0	LINE	
F0857276	F0857276092	0	SHEATH	
F0858540	F0858540000	0	BUSHING	
F0862600	F0862600000	0	SPECIAL SCREW M10X21	

Pos.	Code	Q.ty	Description	Notes
31111091	31111091	1	SCREW E M6X14 UNI 5739 8G	
31152085	31152085	1	SCREW TCEI M8X25 UNI 5931	
31241080	31241080	1	SELFLOCK NUT M8	
31411084	31411084	1	WASHER 8,4x17	
56148218	56148218	1	BRAKE DRUM	
56349649	56349649	1	STOP	
58042167	58042167	1	SHEATH TERMINAL	
58042200	58042200	1	CLAMPING SCREW	
58048214	58048214	1	BRAKE BLOCK	
58048215	58048215	1	SPRING	
59048200	59048200	1	HALF DISC	
59048208	59048208	1	HALF DISC	

	A	B	C	D
4.00 - 8"	391.14008	394.14008	G 580.43250	924.80719 (Kg .11)
4.0 - 10"	391.14010	394.14010	G 580.48330	924.80720 (Kg .15)
5.0-10"	391.15010	394.15010	G 580.48330	924.80720 (Kg. 15)
5.00 - 12"	391.15012	394.15012	G 580.44804	924.80721 (Kg .34)
6.5/80-12"	391.16018	394.16018	G 580.44804	924.80721 (Kg .34)

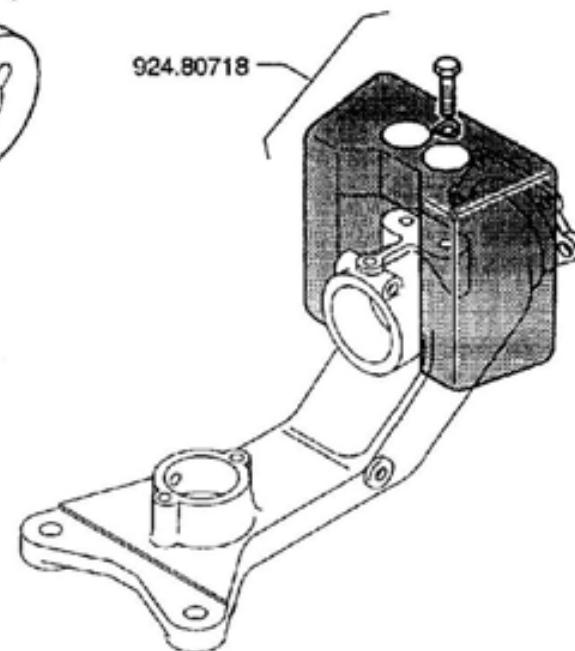
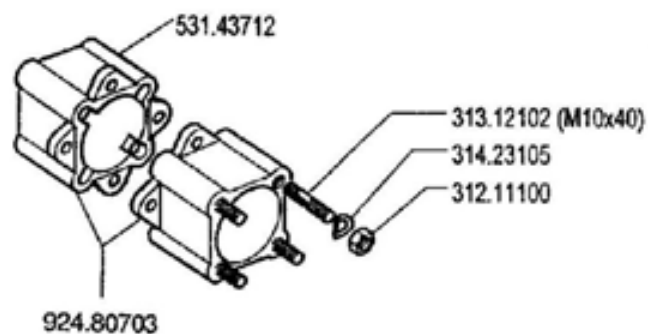
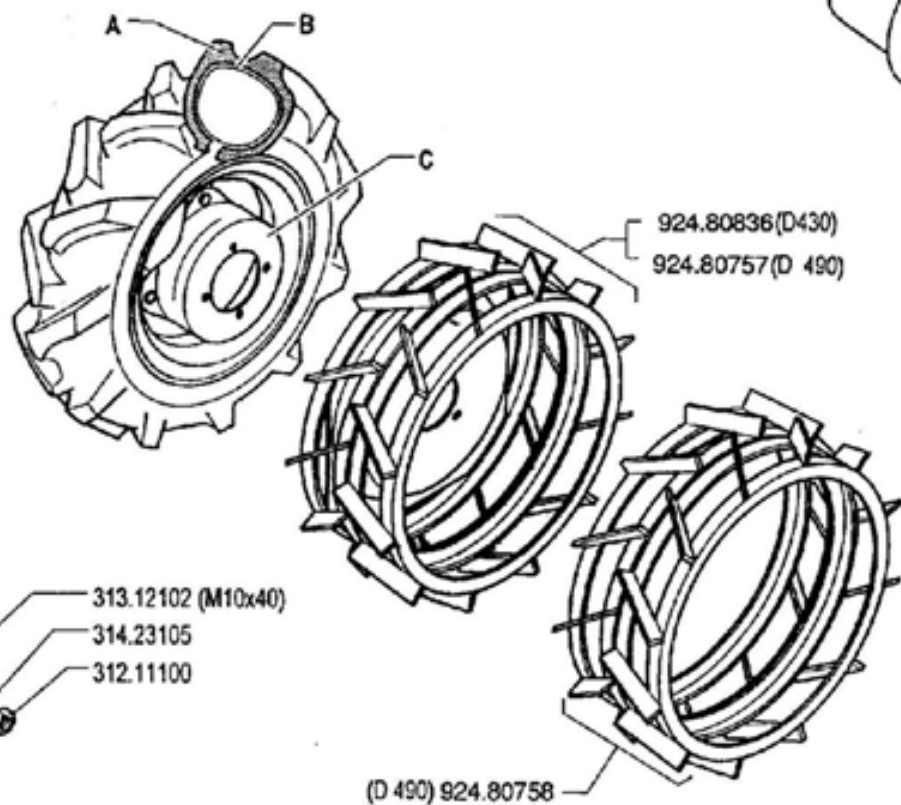
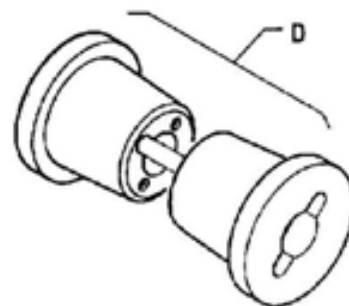

G = giallo - amarillo - jaune - yellow - gelb

FERRARI

300 serie **95**

RUEDAS
ROUES

RUOTE

WHEELS
RÄDER

DALLA MACCHINA
DE LA MACCHINA
DE LA MACHINE
FROM THE MACHINE
AB DER MASCHINE

N.

15.00

01.06.1995

Pos.	Code	Q.ty	Description	Notes
31211100	31211100	0	NUT M10	
31312102	31312102	0	STUD BOLT M10X40X24X12	
31423105	31423105	0	SPRING WASHER 10,5	
39114008	39114008	0	TYRE 4.00-8 2PR	
39114010	39114010	0	TYRE 4.0-10 2PR	
39115010	39115010	0	TYRE 5.00-10 2PR	
39115012	39115012	0	TYRE 5.00-12 2PR	
39116018	39116018	0	TYRE 6.5/80-12 2PR	
39414008	39414008	0	INNER TUBE	
39414010	39414010	0	INNER TUBE	
39415010	39415010	0	INNER TUBE	
39415012	39415012	0	INNER TUBE	
39416018	39416018	0	INNER TUBE	
53143712	53143712	0	SPACER	
58043250	58043250	0	RIM	
58044804	58044804	0	RIM	
58048330	58048330	0	RIM	
92480703	92480703	0	SPACER CM. 6 FOR WHEELS (PAIR)(0901012301)	
92480718	92480718	0	WEIGHT KG. 12 FOR CUTTER BAR FOR 90SLB/305/306/307/792/794	
92480719	92480719	0	WEIGHTS KG. 11 FOR WHEELS 4.00-8 FOR 305/306 (PAIR)	
92480720	92480720	0	WEIGHTS KG. 15 FOR WHEELS 4.0-10 AND 5.0-10 FOR 305/306/307 (PAIR)	
92480721	92480721	0	WEIGHTS KG. 34 FOR WHEELS 5.00-12 / 6.5/80-12 (PAIR) (0901012307)	
92480757	92480757	0	CAGE WHEELS DIAM. CM. 49 FOR 306/30 (PAIR) (0901012315)	
92480758	92480758	0	ADAPTER RINGS FOR MOUNTING STEEL CAGE WHEELS CM. 49 (PAIR)	
92480836	92480836	0	STEEL CAGE WHEELS DIAM. 43 CM.	

	A	B	C ★	D
4.00 - 8"	391.14008	394.14008	580.52326	924.80719 (Kg .11)
4.0 - 10"	391.14010	394.14010	580.52327	924.80720 (Kg .15)
5.0-10"	391.15010	394.15010	580.52327	924.80720 (Kg .15)
5.00 - 12"	391.15012	394.15012	580.52328	924.80721 (Kg .34)
6.5/80-12"	391.16018	394.16018	580,52328	924.80721 (Kg .34)

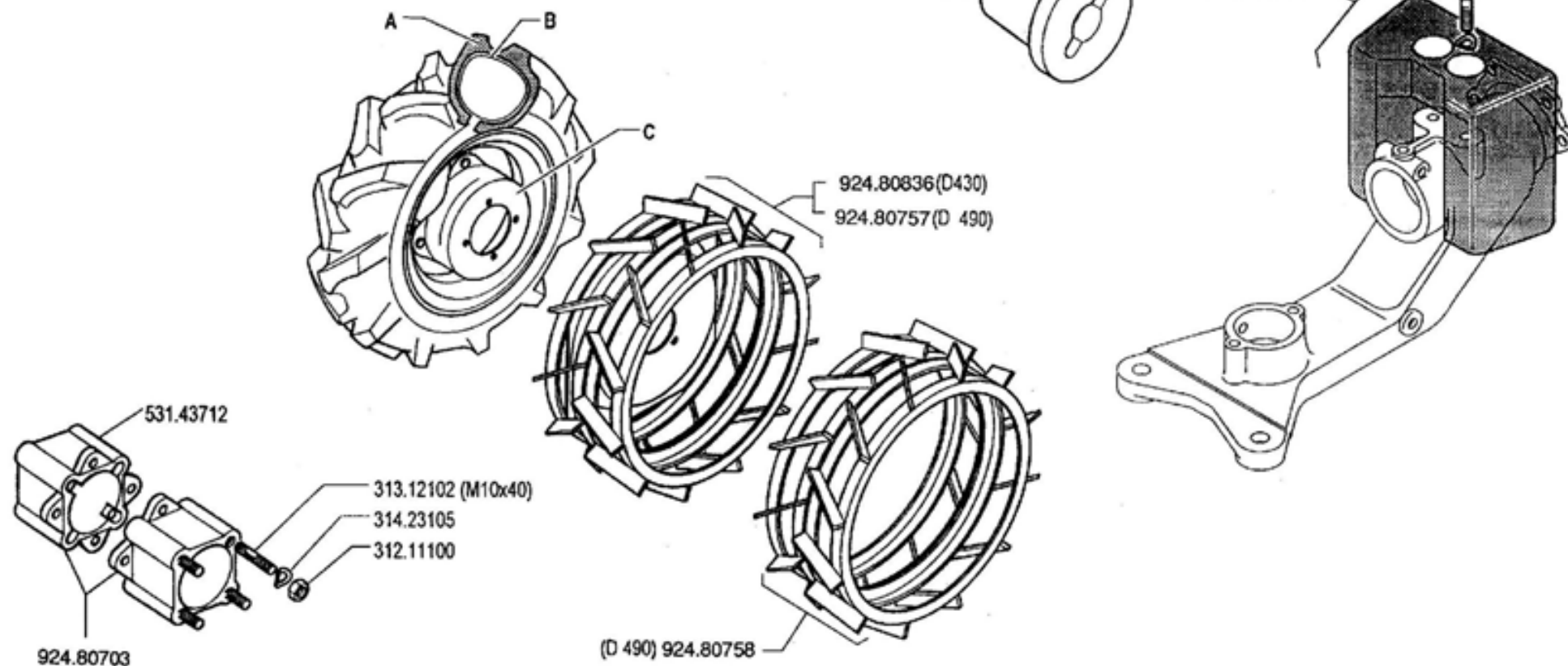

FERRARI

300 serie 95

RUOTE

WHEELS
RUEDAS

ROUES
RÄDER

DALLA MACCHINA
DE LA MAQUINA
DE LA MACHINE
FROM THE MACHINE
AB DER MASCHINE

AGGIORNAMENTO
REVISION
MISE A JOUR
APLAZAMIENTO
ANPASSUNG

15

01

11/1996

★N.

27846

Pos.	Code	Q.ty	Description	Notes
31211100	31211100	0	NUT M10	
31312102	31312102	0	STUD BOLT M10X40X24X12	
31423105	31423105	0	SPRING WASHER 10,5	
39114008	39114008	0	TYRE 4.00-8 2PR	
39114010	39114010	0	TYRE 4.0-10 2PR	
39115010	39115010	0	TYRE 5.00-10 2PR	
39115012	39115012	0	TYRE 5.00-12 2PR	
39116018	39116018	0	TYRE 6.5/80-12 2PR	
39414008	39414008	0	INNER TUBE	
39414010	39414010	0	INNER TUBE	
39415010	39415010	0	INNER TUBE	
39415012	39415012	0	INNER TUBE	
39416018	39416018	0	INNER TUBE	
53143712	53143712	0	SPACER	
58052326	58052326	0	RIM	
58052327	58052327	0	RIM	
58052328	58052328	0	RIM	
92480703	92480703	0	SPACER CM. 6 FOR WHEELS (PAIR)(0901012301)	
92480718	92480718	0	WEIGHT KG. 12 FOR CUTTER BAR FOR 90SLB/305/306/307/792/794	
92480719	92480719	0	WEIGHTS KG. 11 FOR WHEELS 4.00-8 FOR 305/306 (PAIR)	
92480720	92480720	0	WEIGHTS KG. 15 FOR WHEELS 4.0-10 AND 5.0-10 FOR 305/306/307 (PAIR)	
92480721	92480721	0	WEIGHTS KG. 34 FOR WHEELS 5.00-12 / 6.5/80-12 (PAIR) (0901012307)	
92480757	92480757	0	CAGE WHEELS DIAM. CM. 49 FOR 306/30 (PAIR) (0901012315)	
92480758	92480758	0	ADAPTER RINGS FOR MOUNTING STEEL CAGE WHEELS CM. 49 (PAIR)	
92480836	92480836	0	STEEL CAGE WHEELS DIAM. 43 CM.	

	A	B	C	D
4.00 - 8"	391.14008	394.14008	580.52326	924.80719 (Kg .11)
4.0 - 10"	391.14010	394.14010	580.52327	924.80720 (Kg .15)
5.0-10"	391.15010	394.15010	580.52327	924.80720 (Kg. 15)
5.00 - 12"	391.15012	394.15012	580.52328	924.80721 (Kg .34)
6.5/80-12"	391.16018	394.16018	580.52328	924.80721 (Kg .34)

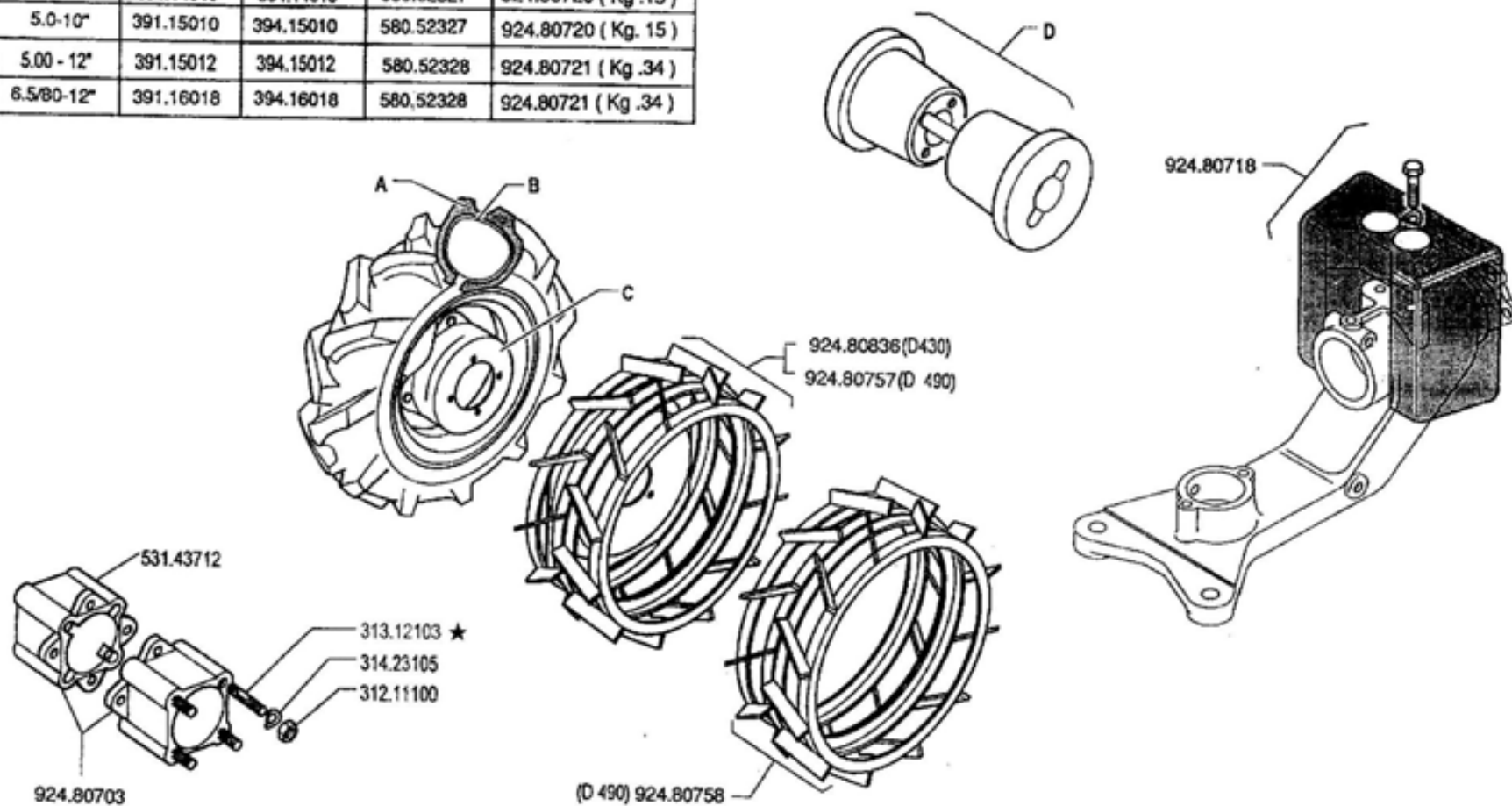

FERRARI

300 serie **95**

RUOTE

WHEELS
RUEDAS

ROUES
RÄDER

DALLA MACCHINA
DE LA MAQUINA
DE LA MACHINE
FROM THE MACHINE
AB DER MASCHINE

AGGIORNAMENTO
REVISION
MISE A JOUR
APLAZAMIENTO
ANPASSUNG

15

Rev.
2

★N

11/1999

LEAVE

Pos.	Code	Q.ty	Description	Notes
31211100	31211100	0	NUT M10	
31312103	31312103	0	STUD BOLT M10X46X24X16	
31423105	31423105	0	SPRING WASHER 10,5	
39114008	39114008	0	TYRE 4.00-8 2PR	
39114010	39114010	0	TYRE 4.0-10 2PR	
39115010	39115010	0	TYRE 5.00-10 2PR	
39115012	39115012	0	TYRE 5.00-12 2PR	
39116018	39116018	0	TYRE 6.5/80-12 2PR	
39414008	39414008	0	INNER TUBE	
39414010	39414010	0	INNER TUBE	
39415010	39415010	0	INNER TUBE	
39415012	39415012	0	INNER TUBE	
39416018	39416018	0	INNER TUBE	
53143712	53143712	0	SPACER	
58052326	58052326	0	RIM	
58052327	58052327	0	RIM	
58052328	58052328	0	RIM	
92480703	92480703	0	SPACER CM. 6 FOR WHEELS (PAIR)(0901012301)	
92480718	92480718	0	WEIGHT KG. 12 FOR CUTTER BAR FOR 90SLB/305/306/307/792/794	
92480719	92480719	0	WEIGHTS KG. 11 FOR WHEELS 4.00-8 FOR 305/306 (PAIR)	
92480720	92480720	0	WEIGHTS KG. 15 FOR WHEELS 4.0-10 AND 5.0-10 FOR 305/306/307 (PAIR)	
92480721	92480721	0	WEIGHTS KG. 34 FOR WHEELS 5.00-12 / 6.5/80-12 (PAIR) (0901012307)	
92480757	92480757	0	CAGE WHEELS DIAM. CM. 49 FOR 306/30 (PAIR) (0901012315)	
92480758	92480758	0	ADAPTER RINGS FOR MOUNTING STEEL CAGE WHEELS CM. 49 (PAIR)	
92480836	92480836	0	STEEL CAGE WHEELS DIAM. 43 CM.	

	A	B	C	D
4.00-8"	39114008	39414008	58052326	92480719 (kg.11)
4.0-10"	39114010	39414010	58052327	92480720 (kg.15)
4.0-10"	39114010	39414010	58052288 (FIX)	/
5.0-10"	39115010	39415010	58052327	92480720 (kg.15)
5.0-10"	39115010	39415010	58052288 (FIX)	/
5.00-12"	39115012	39415012	58052328	92480721 (kg.34)
6.5/80-12"	39116018	39416018	58052328	92480721 (kg.34)

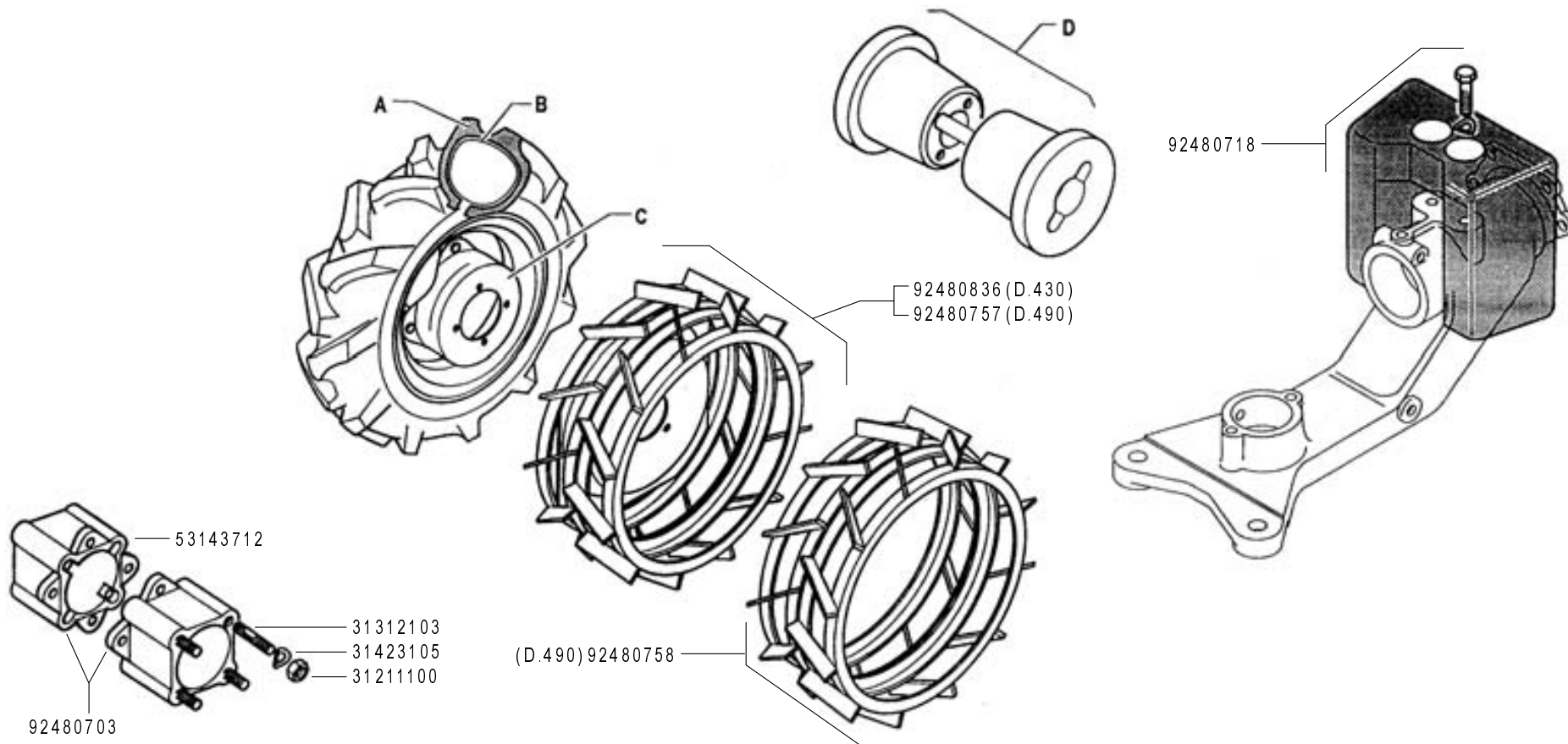

FERRARI

300 serie **95**

RUOTE

WHEELS
RUEDAS

ROUES
RÄDER

DALLA MACCHINA
DE LA MAQUINA
FROM THE MACHINE
AB DER MASCHINE

★ N.

AGGIORNAMENTO
REVISION
MISE A JOUR
APLAZAMIENTO
ANPASSUNG

15

Rev.
3

01/2008

ZENNE

Pos.	Code	Q.ty	Description	Notes
31211100	31211100	1	NUT M10	
31312103	31312103	1	STUD BOLT M10X46X24X16	
31423105	31423105	1	SPRING WASHER 10,5	
39114008	39114008	1	TYRE 4.00-8 2PR	
39114010	39114010	1	TYRE 4.0-10 2PR	
39115010	39115010	1	TYRE 5.00-10 2PR	
39115012	39115012	1	TYRE 5.00-12 2PR	
39116018	39116018	1	TYRE 6.5/80-12 2PR	
39414008	39414008	1	INNER TUBE	
39414010	39414010	1	INNER TUBE	
39415010	39415010	1	INNER TUBE	
39415012	39415012	1	INNER TUBE	
39416018	39416018	1	INNER TUBE	
53143712	53143712	1	SPACER	
58052288	58052288	1	RIM	
58052326	58052326	1	RIM	
58052327	58052327	1	RIM	
58052328	58052328	1	RIM	
92480703	92480703	1	SPACER CM. 6 FOR WHEELS (PAIR)(0901012301)	
92480718	92480718	1	WEIGHT KG. 12 FOR CUTTER BAR FOR 90SLB/305/306/307/792/794	
92480719	92480719	1	WEIGHTS KG. 11 FOR WHEELS 4.00-8 FOR 305/306 (PAIR)	
92480720	92480720	1	WEIGHTS KG. 15 FOR WHEELS 4.0-10 AND 5.0-10 FOR 305/306/307 (PAIR)	
92480721	92480721	1	WEIGHTS KG. 34 FOR WHEELS 5.00-12 / 6.5/80-12 (PAIR) (0901012307)	
92480757	92480757	1	CAGE WHEELS DIAM. CM. 49 FOR 306/30 (PAIR) (0901012315)	
92480758	92480758	1	ADAPTER RINGS FOR MOUNTING STEEL CAGE WHEELS CM. 49 (PAIR)	
92480836	92480836	1	STEEL CAGE WHEELS DIAM. 43 CM.	

SERIAL

WHEELS

CODE REV

015_3_64117

340 580.52013

FERRARI 580.52019

320 580.52025

320 580.52026

330 580.52027

330 580.52028

FERRARI 580.52029

310 580.52035

310 580.52036



580.46912



580.57677



580.46902



580.46909



580.46901

FRIZIONE EMBRAYAGE EMBRAGUE 580.46903



580.57676

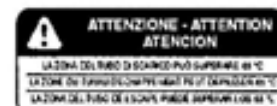

580.46910



580.46913



580.57678



580.57688



580.57704



580.57724

FERRARI

300 serie 95

ADESIVI

STICKERS ADHESIVOS

AUTOCOLLANTS AUFKLEBES

DALLA MACCHINA DE LA MAQUINA DE LA MACHINE FROM THE MACHINE AB DER MASCHINE

N.

16 00

9/1997

Vol

ZENIT

Pos.	Code	Q.ty	Description	Notes
58046901	58046901	0	DECAL	
58046902	58046902	0	DECAL	
58046903	58046903	0	DECAL	
58046909	58046909	0	DECAL	
58046910	58046910	0	DECAL	
58046912	58046912	0	DECAL	
58046913	58046913	0	DECAL	
58052013	58052013	0	DECAL	
58052019	58052019	0	DECAL	
58052025	58052025	0	DECAL	
58052026	58052026	0	DECAL	
58052027	58052027	0	DECAL	
58052028	58052028	0	DECAL	
58052029	58052029	0	DECAL	
58052035	58052035	0	DECAL	
58052036	58052036	0	DECAL	
58057676	58057676	0	DECAL	
58057677	58057677	0	DECAL	
58057678	58057678	0	DECAL	
58057688	58057688	0	DECAL	
58057704	58057704	0	DECAL	
58057724	58057724	0	DECAL	

Pos.	Code	Q.ty	Description	Notes
58046912	58046912	0	DECAL	
58046913	58046913	0	DECAL	
58052013	58052013	0	DECAL	
58052019	58052019	0	DECAL	
58052025	58052025	0	DECAL	
58052026	58052026	0	DECAL	
58052027	58052027	0	DECAL	
58052028	58052028	0	DECAL	
58052029	58052029	0	DECAL	
58052035	58052035	0	DECAL	
58052036	58052036	0	DECAL	
58057676	58057676	0	DECAL	
58057677	58057677	0	DECAL	
58057678	58057678	0	DECAL	
58057688	58057688	0	DECAL	
58057704	58057704	0	DECAL	
58057724	58057724	0	DECAL	
58057767	58057767	0	DECAL	
58057768	58057768	0	DECAL	
58057770	58057770	0	DECAL	
58057772	58057772	0	DECAL	

Pos.	Code	Q.ty	Description	Notes
58046912	58046912	1	DECAL	
58046913	58046913	1	DECAL	
58047729	58047729	1	DECAL	
58057676	58057676	1	DECAL	
58057677	58057677	1	DECAL	
58057678	58057678	1	DECAL	
58057688	58057688	1	DECAL	
58057704	58057704	1	DECAL	
58057724	58057724	1	DECAL	
58057767	58057767	1	DECAL	
58057768	58057768	1	DECAL	
58057770	58057770	1	DECAL	
58057772	58057772	1	DECAL	

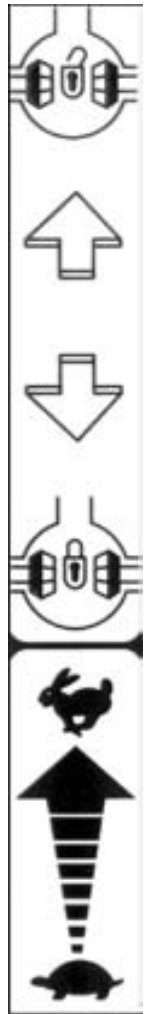

58057688



58057767



58057768



58057772



58057724



58093089



58057746



58057748



58057773



58057774



58057625



58057704



58057770



58057677



58046912

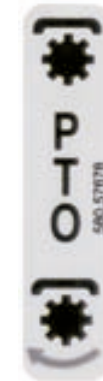

58057678



58057676

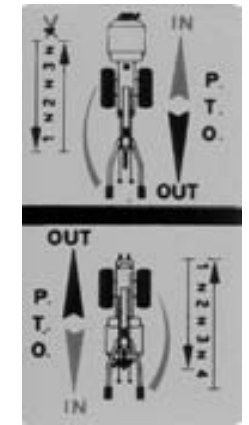

58047729

FERRARI

300 serie 95

ADESIVI

STICKERS
ADHESIVOS

AUTOCOLLANTS
AUFKLEBES

DALLA MACCHINA
DE LA MAQUINA
FROM THE MACHINE
AB DER MASCHINE

AGGIORNAMENTO

REVISION

MISE A JOUR

APLAZAMIENTO

ANPASSUNG

16

07/2006

Rev.

3

★ N.

ZENNE

Pos.	Code	Q.ty	Description	Notes
58046912	58046912	1	DECAL	
58047729	58047729	1	DECAL	
58057625	58057625	1	DECAL	
58057676	58057676	1	DECAL	
58057677	58057677	1	DECAL	
58057678	58057678	1	DECAL	
58057688	58057688	1	DECAL	
58057704	58057704	1	DECAL	
58057724	58057724	1	DECAL	
58057746	58057746	1	DECAL	
58057748	58057748	1	DECAL	
58057767	58057767	1	DECAL	
58057768	58057768	1	DECAL	
58057770	58057770	1	DECAL	
58057772	58057772	1	DECAL	
58057773	58057773	1	DECAL	
58057774	58057774	1	DECAL	
58093089	58093089	1	DECAL	

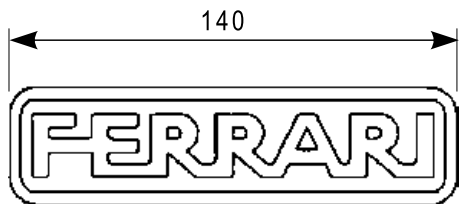

58052029



58052035



58052036



58052019



58052026



58052025



58052028



58052027



58052152 ★



58052013

ADESIVI



300 serie 95

STICKERS
ADHESIVOS

AUTOCOLLANTS
AUFKLEBES

DALLA MACCHINA
DE LA MAQUINA
DE LA MACHINE
FROM THE MACHINE
AB DER MASCHINE

★ N.

AGGIORNAMENTO
REVISION
MISE A JOUR
APLAZAMIENTO
ANPASSUNG

17

Rev.
0

02/2006

ZENNE

Pos.	Code	Q.ty	Description	Notes
58052013	58052013	1	DECAL	
58052019	58052019	1	DECAL	
58052025	58052025	1	DECAL	
58052026	58052026	1	DECAL	
58052027	58052027	1	DECAL	
58052028	58052028	1	DECAL	
58052029	58052029	1	DECAL	
58052035	58052035	1	DECAL	
58052036	58052036	1	DECAL	
58052152	58052152	1	DECAL	

SPARE PARTS INSTANCE INDEX





SPARE PARTS INSTANCE INDEX

Code	Parts Table	Pos.	Q.ty	Code	Parts Table	Pos.	Q.ty	Code	Parts Table	Pos.	Q.ty
30000001	011_2_11372	30000001	0	31100451	011_7_63924	31100451	1	31111097	013_3_11857	31111097	0
	011_3_11435	30000001	0		013_6_33211	31100451	1		013_4_25436	31111097	1
30000276	002_2_10522	30000276	0		013_7_64065	31100451	1		013_5_32888	31111097	1
	002_3_10539	30000276	0	31100786	003_0_10557	31100786	0		013_6_33211	31111097	1
	002_4_23307	30000276	0		003_1_10576	31100786	0		013_7_64065	31111097	1
	002_5_25058	30000276	1		003_2_10596	31100786	0	31111151	001_0_10370	31111151	0
30000277	002_2_10522	30000277	0		003_3_25078	31100786	1		001_2_10428	31111151	0
	002_3_10539	30000277	0	31100787	003_0_10557	31100787	0		001_3_10453	31111151	0
	002_4_23307	30000277	0		003_1_10576	31100787	0		001_4_23329	31111151	0
	002_5_25058	30000277	1		003_2_10596	31100787	0	31111229	011_4_25304	31111229	1
	002_6_33590	30000277	1		003_3_25078	31100787	1		011_5_32699	31111229	1
	002_7_63846	30000277	1	31104020	003_3_25078	31104020	1		011_6_33168	31111229	1
30000295	002_5_25058	30000295	1	31111086	011_4_25304	31111086	1		011_7_63924	31111229	1
	002_6_33590	30000295	1		011_5_32699	31111086	1	31112089	013_0_11706	31112089	0
	002_7_63846	30000295	1		011_6_33168	31111086	1		013_1_11755	31112089	0
30010120	011A_0_25340	30010120	1		011_7_63924	31111086	1		013_2_11805	31112089	0
	011A_1_32745	30010120	1		013_0_11706	31111086	0		013_3_11857	31112089	0
30040001	004_0_10617	30040001	0		013_1_11755	31111086	0		013_4_25436	31112089	1
	004_1_10650	30040001	0		013_2_11805	31111086	0		013_5_32888	31112089	1
	004_2_10685	30040001	0		013_3_11857	31111086	0		013_6_33211	31112089	1
	004_3_10722	30040001	0	31111090	004_0_10617	31111090	0		013_7_64065	31112089	1
	004_4_25109	30040001	1		004_1_10650	31111090	0	31112090	006_3_25213	31112090	1
31100003	003_0_10557	31100003	0		004_2_10685	31111090	0		014_0_11909	31112090	0
	003_1_10576	31100003	0		004_3_10722	31111090	0	31112092	013_0_11706	31112092	0
	003_2_10596	31100003	0		004_4_25109	31111090	1		013_1_11755	31112092	0
	003_3_25078	31100003	1	31111091	001_1_10402	31111091	0		013_2_11805	31112092	0
	003_4_27606	31100003	1		001_2_10428	31111091	0		013_3_11857	31112092	0
	003_5_33490	31100003	1		001_3_10453	31111091	0		013_4_25436	31112092	1
31100015	003_3_25078	31100015	1		001_4_23329	31111091	0		013_5_32888	31112092	1
	003_4_27606	31100015	1		014_1_11927	31111091	0		013_6_33211	31112092	1
	003_5_33490	31100015	1		014_2_25485	31111091	1		013_7_64065	31112092	1
31100201	002_7_63846	31100201	1	31111097	013_0_11706	31111097	0	31112093	001_5_24839	31112093	1
31100451	011A_1_32745	31100451	1		013_1_11755	31111097	0		001_6_63810	31112093	1
	011_6_33168	31100451	1		013_2_11805	31111097	0	31112148	011A_0_25340	31112148	1



SPARE PARTS INSTANCE INDEX

Code	Parts Table	Pos.	Q.ty	Code	Parts Table	Pos.	Q.ty	Code	Parts Table	Pos.	Q.ty
31112148	011A_1_32745	31112148	1	31112154	001_6_63810	31112154	1	31152085	014_0_11909	31152085	0
	011_0_11257	31112148	0		011_4_25304	31112154	1		014_1_11927	31152085	0
	011_1_11314	31112148	0		011_5_32699	31112154	1		014_2_25485	31152085	1
	011_2_11372	31112148	0		011_6_33168	31112154	1	31152103	004_0_10617	31152103	0
	011_3_11435	31112148	0		011_7_63924	31112154	1		004_1_10650	31152103	0
31112149	011A_0_25340	31112149	1		013_6_33211	31112154	1		004_2_10685	31152103	0
	011A_1_32745	31112149	1		013_7_64065	31112154	1		004_3_10722	31152103	0
	011_0_11257	31112149	0	31112210	004_3_10722	31112210	0		004_4_25109	31152103	1
	011_1_11314	31112149	0		004_4_25109	31112210	1	31211040	013_0_11706	31211040	0
	011_2_11372	31112149	0	31112211	006_0_10884	31112211	0		013_1_11755	31211040	0
	011_3_11435	31112149	0		006_1_10921	31112211	0		013_2_11805	31211040	0
31112150	001_0_10370	31112150	0		006_2_10958	31112211	0		013_3_11857	31211040	0
	001_1_10402	31112150	0		006_3_25213	31112211	1	31211080	001_0_10370	31211080	0
	004_0_10617	31112150	0	31112213	001_0_10370	31112213	0		001_1_10402	31211080	0
	004_1_10650	31112150	0	31112293	011_4_25304	31112293	1		001_2_10428	31211080	0
	004_2_10685	31112150	0		011_5_32699	31112293	1		001_3_10453	31211080	0
	004_3_10722	31112150	0		011_6_33168	31112293	1		001_4_23329	31211080	0
	004_4_25109	31112150	1		011_7_63924	31112293	1		001_5_24839	31211080	1
	011_4_25304	31112150	1	31112701	011A_0_25340	31112701	1		001_6_63810	31211080	1
	011_5_32699	31112150	1		011A_1_32745	31112701	1		003_0_10557	31211080	0
	011_6_33168	31112150	1	31121558	002_2_10522	31121558	0		003_1_10576	31211080	0
	011_7_63924	31112150	1		002_3_10539	31121558	0		003_2_10596	31211080	0
31112152	009_0_11080	31112152	0		002_4_23307	31121558	0		003_3_25078	31211080	1
	009_1_11107	31112152	0		002_5_25058	31121558	1		003_4_27606	31211080	1
31112153	013_0_11706	31112153	0		002_6_33590	31121558	1		003_5_33490	31211080	1
	013_1_11755	31112153	0		002_7_63846	31121558	1		011_4_25304	31211080	1
	013_2_11805	31112153	0	31121559	001_6_63810	31121559	1		011_5_32699	31211080	1
	013_3_11857	31112153	0	31132562	004_1_10650	31132562	0		011_6_33168	31211080	1
	013_6_33211	31112153	1		004_2_10685	31132562	0		011_7_63924	31211080	1
	013_7_64065	31112153	1		004_3_10722	31132562	0		013_0_11706	31211080	0
31112154	001_2_10428	31112154	0		004_4_25109	31132562	1		013_1_11755	31211080	0
	001_3_10453	31112154	0	31152057	001_0_10370	31152057	0		013_2_11805	31211080	0
	001_4_23329	31112154	0	31152084	013_4_25436	31152084	1		013_3_11857	31211080	0
	001_5_24839	31112154	1		013_5_32888	31152084	1		013_4_25436	31211080	1



SPARE PARTS INSTANCE INDEX

Code	Parts Table	Pos.	Q.ty	Code	Parts Table	Pos.	Q.ty	Code	Parts Table	Pos.	Q.ty
31211080	013_5_32888	31211080	1	31241060	013_2_11805	31241060	0	31241080	013_2_11805	31241080	0
	013_6_33211	31211080	1		013_3_11857	31241060	0		013_3_11857	31241080	0
	013_7_64065	31211080	1		013_4_25436	31241060	1		013_4_25436	31241080	1
31211100	004_0_10617	31211100	0		013_5_32888	31241060	1		013_5_32888	31241080	1
	004_1_10650	31211100	0		013_6_33211	31241060	1		014_2_25485	31241080	1
	004_2_10685	31211100	0		013_7_64065	31241060	1	31241085	004_0_10617	31241085	0
	004_3_10722	31211100	0	31241080	001_2_10428	31241080	0		004_1_10650	31241085	0
	009_0_11080	31211100	0		001_3_10453	31241080	0		004_2_10685	31241085	0
	009_1_11107	31211100	0		001_4_23329	31241080	0		004_3_10722	31241085	0
	011_2_11372	31211100	0		001_5_24839	31241080	1		004_4_25109	31241085	1
	011_3_11435	31211100	0		001_6_63810	31241080	1	31241100	001_0_10370	31241100	0
	015_0_11945	31211100	0		002_2_10522	31241080	0		011_4_25304	31241100	1
	015_1_11971	31211100	0		002_3_10539	31241080	0		011_5_32699	31241100	1
	015_2_11997	31211100	0		002_4_23307	31241080	0		011_6_33168	31241100	1
	015_3_64117	31211100	1		003_3_25078	31241080	1		011_7_63924	31241100	1
31215100	011_0_11257	31215100	0		003_4_27606	31241080	1	31241101	011_0_11257	31241101	0
	011_1_11314	31215100	0		003_5_33490	31241080	1		011_1_11314	31241101	0
31221121	004_0_10617	31221121	0		004_0_10617	31241080	0		011_2_11372	31241101	0
	004_1_10650	31221121	0		004_1_10650	31241080	0		011_3_11435	31241101	0
	004_2_10685	31221121	0		004_2_10685	31241080	0	31241120	011A_0_25340	31241120	1
	004_3_10722	31221121	0		004_3_10722	31241080	0		011A_1_32745	31241120	1
	004_4_25109	31221121	1		004_4_25109	31241080	1	31241126	011_4_25304	31241126	1
31241060	001_0_10370	31241060	0		009_0_11080	31241080	0		011_5_32699	31241126	1
	001_1_10402	31241060	0		009_1_11107	31241080	0		011_6_33168	31241126	1
	001_5_24839	31241060	1		011A_0_25340	31241080	1		011_7_63924	31241126	1
	001_6_63810	31241060	1		011A_1_32745	31241080	1	31312080	009_0_11080	31312080	0
	002_2_10522	31241060	0		011_0_11257	31241080	0		009_1_11107	31312080	0
	002_3_10539	31241060	0		011_1_11314	31241080	0	31312082	004_0_10617	31312082	0
	002_4_23307	31241060	0		011_2_11372	31241080	0		004_1_10650	31312082	0
	002_5_25058	31241060	1		011_3_11435	31241080	0		004_2_10685	31312082	0
	002_6_33590	31241060	1		011_4_25304	31241080	1		004_3_10722	31312082	0
	002_7_63846	31241060	1		011_5_32699	31241080	1		004_4_25109	31312082	1
	013_0_11706	31241060	0		011_6_33168	31241080	1	31312083	003_0_10557	31312083	0
	013_1_11755	31241060	0		011_7_63924	31241080	1		003_1_10576	31312083	0



SPARE PARTS INSTANCE INDEX

Code	Parts Table	Pos.	Q.ty	Code	Parts Table	Pos.	Q.ty	Code	Parts Table	Pos.	Q.ty
31312083	003_2_10596	31312083	0	31312103	015_3_64117	31312103	1	31411084	011A_1_32745	31411084	1
	003_3_25078	31312083	1	31312124	004_3_10722	31312124	0		011_0_11257	31411084	0
	003_4_27606	31312083	1		004_4_25109	31312124	1		011_1_11314	31411084	0
	003_5_33490	31312083	1	31312125	004_0_10617	31312125	0		011_2_11372	31411084	0
31312084	004_0_10617	31312084	0		004_1_10650	31312125	0		011_3_11435	31411084	0
	004_1_10650	31312084	0		004_2_10685	31312125	0		013_0_11706	31411084	0
	004_2_10685	31312084	0		004_3_10722	31312125	0		013_1_11755	31411084	0
	004_3_10722	31312084	0		004_4_25109	31312125	1		013_2_11805	31411084	0
	004_4_25109	31312084	1	31411043	011_4_25304	31411043	1		013_3_11857	31411084	0
31312086	004_0_10617	31312086	0		011_5_32699	31411043	1		013_4_25436	31411084	1
	004_1_10650	31312086	0		011_6_33168	31411043	1		013_5_32888	31411084	1
	004_2_10685	31312086	0		011_7_63924	31411043	1		014_2_25485	31411084	1
	004_3_10722	31312086	0		013_0_11706	31411043	0	31411090	001_6_63810	31411090	1
	004_4_25109	31312086	1		013_1_11755	31411043	0		002_7_63846	31411090	1
31312088	003_0_10557	31312088	0		013_2_11805	31411043	0	31411104	001_0_10370	31411104	0
	003_1_10576	31312088	0		013_3_11857	31411043	0		001_1_10402	31411104	0
	003_2_10596	31312088	0	31411064	001_5_24839	31411064	1		001_2_10428	31411104	0
	003_3_25078	31312088	1		001_6_63810	31411064	1		001_3_10453	31411104	0
	003_4_27606	31312088	1		002_5_25058	31411064	1		001_4_23329	31411104	0
	003_5_33490	31312088	1		002_6_33590	31411064	1		001_5_24839	31411104	1
31312094	004_0_10617	31312094	0		002_7_63846	31411064	1		001_6_63810	31411104	1
	004_1_10650	31312094	0		013_0_11706	31411064	0		011A_0_25340	31411104	1
	004_2_10685	31312094	0		013_1_11755	31411064	0		011A_1_32745	31411104	1
	004_3_10722	31312094	0		013_2_11805	31411064	0		011_0_11257	31411104	0
	004_4_25109	31312094	1		013_3_11857	31411064	0		011_1_11314	31411104	0
31312101	004_0_10617	31312101	0	31411084	001_2_10428	31411084	0		011_2_11372	31411104	0
	004_1_10650	31312101	0		001_3_10453	31411084	0		011_3_11435	31411104	0
	004_2_10685	31312101	0		001_4_23329	31411084	0	31411130	011A_0_25340	31411130	1
	004_3_10722	31312101	0		001_5_24839	31411084	1		011A_1_32745	31411130	1
31312102	009_0_11080	31312102	0		001_6_63810	31411084	1	31414130	011A_0_25340	31414130	1
	009_1_11107	31312102	0		003_3_25078	31411084	1		011A_1_32745	31414130	1
	015_0_11945	31312102	0		009_0_11080	31411084	0		011_2_11372	31414130	0
	015_1_11971	31312102	0		009_1_11107	31411084	0		011_3_11435	31414130	0
31312103	015_2_11997	31312103	0		011A_0_25340	31411084	1	31421083	001_0_10370	31421083	0



SPARE PARTS INSTANCE INDEX

Code	Parts Table	Pos.	Q.ty	Code	Parts Table	Pos.	Q.ty	Code	Parts Table	Pos.	Q.ty
31421083	001_1_10402	31421083	0	31422064	001_3_10453	31422064	0	31423084	011_1_11314	31423084	0
	002_2_10522	31421083	0		001_4_23329	31422064	0		011_2_11372	31423084	0
	002_3_10539	31421083	0		004_0_10617	31422064	0		011_3_11435	31423084	0
	002_4_23307	31421083	0		004_1_10650	31422064	0		011_4_25304	31423084	1
	004_0_10617	31421083	0		004_2_10685	31422064	0		011_5_32699	31423084	1
	004_1_10650	31421083	0		004_3_10722	31422064	0		011_6_33168	31423084	1
	004_2_10685	31421083	0		004_4_25109	31422064	1		011_7_63924	31423084	1
	004_3_10722	31421083	0	31423043	013_0_11706	31423043	0		013_0_11706	31423084	0
	004_4_25109	31421083	1		013_1_11755	31423043	0		013_1_11755	31423084	0
	011A_0_25340	31421083	1		013_2_11805	31423043	0		013_2_11805	31423084	0
	011A_1_32745	31421083	1		013_3_11857	31423043	0		013_3_11857	31423084	0
	011_0_11257	31421083	0	31423084	001_0_10370	31423084	0		013_4_25436	31423084	1
	011_1_11314	31421083	0		001_1_10402	31423084	0		013_5_32888	31423084	1
	011_2_11372	31421083	0		001_2_10428	31423084	0		013_6_33211	31423084	1
	011_3_11435	31421083	0		001_3_10453	31423084	0		013_7_64065	31423084	1
	011_4_25304	31421083	1		001_4_23329	31423084	0	31423105	003_3_25078	31423105	1
	011_5_32699	31421083	1		001_5_24839	31423084	1		003_4_27606	31423105	1
	011_6_33168	31421083	1		001_6_63810	31423084	1		003_5_33490	31423105	1
	011_7_63924	31421083	1		003_0_10557	31423084	0		004_0_10617	31423105	0
31421100	011_4_25304	31421100	1		003_1_10576	31423084	0		004_1_10650	31423105	0
	011_5_32699	31421100	1		003_2_10596	31423084	0		004_2_10685	31423105	0
	011_6_33168	31421100	1		003_3_25078	31423084	1		004_3_10722	31423105	0
	011_7_63924	31421100	1		003_4_27606	31423084	1		009_0_11080	31423105	0
31421101	004_3_10722	31421101	0		003_5_33490	31423084	1		009_1_11107	31423105	0
	004_4_25109	31421101	1		004_0_10617	31423084	0		011_0_11257	31423105	0
	006_0_10884	31421101	0		004_1_10650	31423084	0		011_1_11314	31423105	0
	006_1_10921	31421101	0		004_2_10685	31423084	0		011_2_11372	31423105	0
	006_2_10958	31421101	0		004_3_10722	31423084	0		011_3_11435	31423105	0
	006_3_25213	31421101	1		004_4_25109	31423084	1		014_0_11909	31423105	0
31421132	004_3_10722	31421132	0		009_0_11080	31423084	0		014_1_11927	31423105	0
	004_4_25109	31421132	1		009_1_11107	31423084	0		015_0_11945	31423105	0
31422064	001_0_10370	31422064	0		011A_0_25340	31423084	1		015_1_11971	31423105	0
	001_1_10402	31422064	0		011A_1_32745	31423084	1		015_2_11997	31423105	0
	001_2_10428	31422064	0		011_0_11257	31423084	0		015_3_64117	31423105	1



SPARE PARTS INSTANCE INDEX

Code	Parts Table	Pos.	Q.ty	Code	Parts Table	Pos.	Q.ty	Code	Parts Table	Pos.	Q.ty
31423130	004_0_10617	31423130	0	34213020	011_3_11435	34213020	0	35111055	006_0_10884	35111055	0
	004_1_10650	31423130	0		013_0_11706	34213020	0		006_1_10921	35111055	0
	004_2_10685	31423130	0		013_1_11755	34213020	0		006_2_10958	35111055	0
31510098	001_0_10370	31510098	0		013_2_11805	34213020	0		006_3_25213	35111055	1
	001_1_10402	31510098	0		013_3_11857	34213020	0	35121012	013_4_25436	35121012	1
31510099	001_0_10370	31510099	0		013_4_25436	34213020	1		013_5_32888	35121012	1
	001_1_10402	31510099	0		013_5_32888	34213020	1	35121014	002_4_23307	35121014	1
31510100	001_2_10428	31510100	0	34213022	011A_0_25340	34213022	1		004_4_25109	35121014	1
	001_3_10453	31510100	0		011A_1_32745	34213022	1	35121031	006_0_10884	35121031	0
	001_4_23329	31510100	0		011_0_11257	34213022	0		006_1_10921	35121031	0
	001_5_24839	31510100	1		011_1_11314	34213022	0		006_2_10958	35121031	0
	001_6_63810	31510100	1		011_2_11372	34213022	0		006_3_25213	35121031	1
34110028	011A_0_25340	34110028	1		011_3_11435	34213022	0	35211120	006_0_10884	35211120	0
	011A_1_32745	34110028	1	34213024	011A_0_25340	34213024	1		006_1_10921	35211120	0
	011_0_11257	34110028	0		011A_1_32745	34213024	1		006_2_10958	35211120	0
	011_1_11314	34110028	0		011_0_11257	34213024	0		006_3_25213	00	1
	011_2_11372	34110028	0		011_1_11314	34213024	0	37111150	006_0_10884	37111150	0
	011_3_11435	34110028	0		011_2_11372	34213024	0		006_1_10921	37111150	0
34110030	001_0_10370	34110030	0		011_3_11435	34213024	0		006_2_10958	37111150	0
	001_1_10402	34110030	0	34213060	006_0_10884	34213060	0		006_3_25213	37111150	1
	001_2_10428	34110030	0		006_1_10921	34213060	0	37111152	006_0_10884	37111152	0
	001_3_10453	34110030	0		006_2_10958	34213060	0		006_1_10921	37111152	0
	001_4_23329	34110030	0		006_3_25213	34213060	1		006_2_10958	37111152	0
	001_5_24839	34110030	1	34213061	006_0_10884	34213061	0		006_3_25213	37111152	1
	001_6_63810	34110030	1		006_1_10921	34213061	0	37111250	009_0_11080	37111250	0
34211042	006_0_10884	34211042	0		006_2_10958	34213061	0		009_1_11107	37111250	0
	006_1_10921	34211042	0		006_3_25213	34213061	1	37111253	009_0_11080	37111253	0
	006_2_10958	34211042	0	35111047	006_3_25213	35111047	1		009_1_11107	37111253	0
	006_3_25213	34211042	1		009_0_11080	35111047	0	37112173	003_0_10557	37112173	0
34213020	011A_0_25340	34213020	1		009_1_11107	35111047	0		003_1_10576	37112173	0
	011A_1_32745	34213020	1	35111053	006_0_10884	35111053	0		003_2_10596	37112173	0
	011_0_11257	34213020	0		006_1_10921	35111053	0		003_3_25078	37112173	1
	011_1_11314	34213020	0		006_2_10958	35111053	0		003_4_27606	37112173	1
	011_2_11372	34213020	0		006_3_25213	35111053	1		003_5_33490	37112173	1



SPARE PARTS INSTANCE INDEX

Code	Parts Table	Pos.	Q.ty	Code	Parts Table	Pos.	Q.ty	Code	Parts Table	Pos.	Q.ty
37112229	006_0_10884	37112229	0	38111400	009_0_11080	38111400	0	39115010	015_3_64117	39115010	1
	006_1_10921	37112229	0		009_1_11107	38111400	0	39115012	015_0_11945	39115012	0
	006_2_10958	37112229	0	38112817	011_0_11257	38112817	0		015_1_11971	39115012	0
	006_3_25213	37112229	1		011_1_11314	38112817	0		015_2_11997	39115012	0
37112231	003_0_10557	37112231	0		011_2_11372	38112817	0		015_3_64117	39115012	1
	003_1_10576	37112231	0		011_3_11435	38112817	0	39116018	015_0_11945	39116018	0
	003_2_10596	37112231	0	38211400	011A_0_25340	38211400	1		015_1_11971	39116018	0
	003_3_25078	37112231	1		011A_1_32745	38211400	1		015_2_11997	39116018	0
	003_4_27606	37112231	1		011_0_11257	38211400	0		015_3_64117	39116018	1
37112233	003_3_25078	37112233	1		011_1_11314	38211400	0	39414008	015_0_11945	39414008	0
	003_4_27606	37112233	1		011_2_11372	38211400	0		015_1_11971	39414008	0
37112252	006_3_25213	37112252	1		011_3_11435	38211400	0		015_2_11997	39414008	0
37141250	006_0_10884	37141250	0	38211500	004_0_10617	38211500	0		015_3_64117	39414008	1
	006_1_10921	37141250	0		004_1_10650	38211500	0	39414010	015_0_11945	39414010	0
	006_2_10958	37141250	0		004_2_10685	38211500	0		015_1_11971	39414010	0
	006_3_25213	37141250	1		004_3_10722	38211500	0		015_2_11997	39414010	0
37320120	006_0_10884	37320120	0		004_4_25109	38211500	1		015_3_64117	39414010	1
	006_1_10921	37320120	0	38213002	009_0_11080	38213002	0	39415010	015_0_11945	39415010	0
	006_2_10958	37320120	0		009_1_11107	38213002	0		015_1_11971	39415010	0
	006_3_25213	37320120	1	38213800	006_0_10884	38213800	0		015_2_11997	39415010	0
37910832	006_0_10884	37910832	0		006_1_10921	38213800	0		015_3_64117	39415010	1
	006_1_10921	37910832	0		006_2_10958	38213800	0	39415012	015_0_11945	39415012	0
	006_2_10958	37910832	0		006_3_25213	38213800	1		015_1_11971	39415012	0
	006_3_25213	37910832	1	39114008	015_0_11945	39114008	0		015_2_11997	39415012	0
37911532	011A_0_25340	37911532	1		015_1_11971	39114008	0		015_3_64117	39415012	1
	011A_1_32745	37911532	1		015_2_11997	39114008	0	39416018	015_0_11945	39416018	0
	011_0_11257	37911532	0		015_3_64117	39114008	1		015_1_11971	39416018	0
	011_1_11314	37911532	0	39114010	015_0_11945	39114010	0		015_2_11997	39416018	0
	011_2_11372	37911532	0		015_1_11971	39114010	0		015_3_64117	39416018	1
	011_3_11435	37911532	0		015_2_11997	39114010	0	50947833	003_0_10557	50947833	0
38111191	011A_0_25340	38111191	1		015_3_64117	39114010	1	50956262	003_1_10576	50956262	0
	011A_1_32745	38111191	1	39115010	015_0_11945	39115010	0		003_2_10596	50956262	0
	011_2_11372	38111191	0		015_1_11971	39115010	0		003_3_25078	50956262	1
	011_3_11435	38111191	0		015_2_11997	39115010	0		003_4_27606	50956262	1



SPARE PARTS INSTANCE INDEX

Code	Parts Table	Pos.	Q.ty	Code	Parts Table	Pos.	Q.ty	Code	Parts Table	Pos.	Q.ty
50956262	003_5_33490	50956262	1	52456354	006_1_10921	52456354	0	53143875	004_2_10685	53143875	0
52156917	011_4_25304	52156917	1		006_2_10958	52456354	0		004_3_10722	53143875	0
	011_5_32699	52156917	1		006_3_25213	52456354	1	53152401	004_3_10722	53152401	0
	011_6_33168	52156917	1	52456359	006_0_10884	52456359	0		004_4_25109	53152401	1
	011_7_63924	52156917	1	52456360	006_1_10921	52456360	0	53152402	004_3_10722	53152402	0
52357250	011A_0_25340	52357250	1		006_2_10958	52456360	0		004_4_25109	53152402	1
	011A_1_32745	52357250	1		006_3_25213	52456360	1	53152408	004_3_10722	53152408	0
	011_0_11257	52357250	0	52456362	006_0_10884	52456362	0		004_4_25109	53152408	1
	011_1_11314	52357250	0		006_1_10921	52456362	0	53152409	004_3_10722	53152409	0
	011_2_11372	52357250	0		006_2_10958	52456362	0		004_4_25109	53152409	1
	011_3_11435	52357250	0		006_3_25213	52456362	1	53152410	004_3_10722	53152410	0
52447896	003_0_10557	52447896	0	52456370	006_0_10884	52456370	0		004_4_25109	53152410	1
	003_1_10576	52447896	0		006_1_10921	52456370	0	53152412	004_3_10722	53152412	0
	003_2_10596	52447896	0		006_2_10958	52456370	0		004_4_25109	53152412	1
	003_3_25078	52447896	1		006_3_25213	52456370	1	53156150	003_3_25078	53156150	1
	003_4_27606	52447896	1	52456389	006_0_10884	52456389	0		003_4_27606	53156150	1
	003_5_33490	52447896	1		006_1_10921	52456389	0		003_5_33490	53156150	1
52448187	009_0_11080	52448187	0		006_2_10958	52456389	0	53156325	004_0_10617	53156325	0
	009_1_11107	52448187	0		006_3_25213	52456389	1		004_1_10650	53156325	0
52448188	009_0_11080	52448188	0	52456390	006_0_10884	52456390	0		004_2_10685	53156325	0
	009_1_11107	52448188	0		006_1_10921	52456390	0		004_3_10722	53156325	0
52456336	006_0_10884	52456336	0		006_2_10958	52456390	0	53156326	004_0_10617	53156326	0
	006_1_10921	52456336	0		006_3_25213	52456390	1		004_1_10650	53156326	0
	006_2_10958	52456336	0	52457866	006_3_25213	52457866	1		004_2_10685	53156326	0
	006_3_25213	52456336	1	53143128	004_0_10617	53143128	0		004_3_10722	53156326	0
52456340	006_0_10884	52456340	0		004_1_10650	53143128	0	53156332	004_0_10617	53156332	0
	006_1_10921	52456340	0		004_2_10685	53143128	0		004_1_10650	53156332	0
	006_2_10958	52456340	0		004_3_10722	53143128	0		004_2_10685	53156332	0
	006_3_25213	52456340	1	53143712	015_0_11945	53143712	0		004_3_10722	53156332	0
52456344	006_0_10884	52456344	0		015_1_11971	53143712	0	53156342	004_1_10650	53156342	0
	006_1_10921	52456344	0		015_2_11997	53143712	0		004_2_10685	53156342	0
52456349	006_2_10958	52456349	0		015_3_64117	53143712	1		004_3_10722	53156342	0
	006_3_25213	52456349	1	53143875	004_0_10617	53143875	0	53156346	004_2_10685	53156346	0
52456354	006_0_10884	52456354	0		004_1_10650	53143875	0		004_3_10722	53156346	0



SPARE PARTS INSTANCE INDEX

Code	Parts Table	Pos.	Q.ty	Code	Parts Table	Pos.	Q.ty	Code	Parts Table	Pos.	Q.ty
53156346	004_4_25109	53156346	1	55157212	011A_1_32745	55157212	1	55247644	011_3_11435	55247644	0
53243851	009_0_11080	53243851	0		011_6_33168	55157212	1	55248038	013_0_11706	55248038	0
	009_1_11107	53243851	0		011_7_63924	55157212	1		013_1_11755	55248038	0
53247468	003_0_10557	53247468	0		013_6_33211	55157212	1		013_2_11805	55248038	0
	003_1_10576	53247468	0		013_7_64065	55157212	1		013_3_11857	55248038	0
	003_2_10596	53247468	0	55157213	011A_1_32745	55157213	1		013_4_25436	55248038	1
	003_3_25078	53247468	1		011_6_33168	55157213	1		013_5_32888	55248038	1
	003_4_27606	53247468	1		011_7_63924	55157213	1		013_6_33211	55248038	1
53247488	003_5_33490	53247488	1		013_6_33211	55157213	1		013_7_64065	55248038	1
55102678	004_0_10617	55102678	0		013_7_64065	55157213	1	55248041	013_0_11706	55248041	0
	004_1_10650	55102678	0	55157214	013_6_33211	55157214	1		013_1_11755	55248041	0
	004_2_10685	55102678	0		013_7_64065	55157214	1		013_2_11805	55248041	0
	004_3_10722	55102678	0	55157215	013_6_33211	55157215	1		013_3_11857	55248041	0
	004_4_25109	55102678	1		013_7_64065	55157215	1		013_4_25436	55248041	1
55102714	011_4_25304	55102714	1	55157609	003_1_10576	55157609	0		013_5_32888	55248041	1
	011_5_32699	55102714	1		003_2_10596	55157609	0		013_6_33211	55248041	1
55142076	011A_0_25340	55142076	1		003_3_25078	55157609	1		013_7_64065	55248041	1
	011_0_11257	55142076	0		003_4_27606	55157609	1	55248241	001_0_10370	55248241	0
	011_1_11314	55142076	0		003_5_33490	55157609	1		001_1_10402	55248241	0
	011_2_11372	55142076	0	55220363	002_4_23307	55220363	1	55248283	013_0_11706	55248283	0
	011_3_11435	55142076	0		004_4_25109	55220363	1		013_1_11755	55248283	0
55142109	001_0_10370	55142109	0	55243340	011_4_25304	55243340	1		013_2_11805	55248283	0
	001_1_10402	55142109	0		011_5_32699	55243340	1		013_3_11857	55248283	0
	001_2_10428	55142109	0		011_6_33168	55243340	1		013_4_25436	55248283	1
	001_3_10453	55142109	0		011_7_63924	55243340	1		013_5_32888	55248283	1
	001_4_23329	55142109	0		013_0_11706	55243340	0	55248284	013_0_11706	55248284	0
	001_5_24839	55142109	1		013_1_11755	55243340	0		013_1_11755	55248284	0
	001_6_63810	55142109	1		013_2_11805	55243340	0		013_2_11805	55248284	0
55147842	003_0_10557	55147842	0		013_3_11857	55243340	0		013_3_11857	55248284	0
	003_1_10576	55147842	0	55247644	011A_0_25340	55247644	1		013_4_25436	55248284	1
	003_2_10596	55147842	0		011A_1_32745	55247644	1		013_5_32888	55248284	1
	003_3_25078	55147842	1		011_0_11257	55247644	0	55248379	011A_0_25340	55248379	1
	003_4_27606	55147842	1		011_1_11314	55247644	0		011A_1_32745	55248379	1
	003_5_33490	55147842	1		011_2_11372	55247644	0		011_0_11257	55248379	0



SPARE PARTS INSTANCE INDEX

Code	Parts Table	Pos.	Q.ty	Code	Parts Table	Pos.	Q.ty	Code	Parts Table	Pos.	Q.ty
55248379	011_1_11314	55248379	0	56137370	002_7_63846	56137370	1	56147646	011_0_11257	56147646	0
	011_2_11372	55248379	0	56142110	001_0_10370	56142110	0		011_1_11314	56147646	0
	011_3_11435	55248379	0		001_1_10402	56142110	0		011_2_11372	56147646	0
55249668	011_4_25304	55249668	1	56143794	001_0_10370	56143794	0		011_3_11435	56147646	0
	011_5_32699	55249668	1	56143878	004_0_10617	56143878	0	56147648	011_0_11257	56147648	0
55252318	001_2_10428	55252318	0		004_1_10650	56143878	0		011_1_11314	56147648	0
	001_3_10453	55252318	0	56143880	009_0_11080	56143880	0		011_2_11372	56147648	0
	001_4_23329	55252318	0		009_1_11107	56143880	0		011_3_11435	56147648	0
	001_5_24839	55252318	1	56143883	009_0_11080	56143883	0	56147655	013_0_11706	56147655	0
	001_6_63810	55252318	1		009_1_11107	56143883	0		013_1_11755	56147655	0
55252406	001_5_24839	55252406	1	56147432	001_0_10370	56147432	0		013_2_11805	56147655	0
	001_6_63810	55252406	1	56147433	001_0_10370	56147433	0		013_3_11857	56147655	0
55252413	001_5_24839	55252413	1		001_1_10402	56147433	0		013_4_25436	56147655	1
	001_6_63810	55252413	1	56147434	001_0_10370	56147434	0		013_5_32888	56147655	1
55257042	013_4_25436	55257042	1		001_1_10402	56147434	0		013_6_33211	56147655	1
	013_5_32888	55257042	1	56147437	001_0_10370	56147437	0		013_7_64065	56147655	1
55257209	013_6_33211	55257209	1		001_1_10402	56147437	0	56147664	011_0_11257	56147664	0
	013_7_64065	55257209	1	56147520	004_0_10617	56147520	0		011_1_11314	56147664	0
55257255	011_0_11257	55257255	0		004_1_10650	56147520	0		011_2_11372	56147664	0
55257313	011A_0_25340	55257313	1		004_2_10685	56147520	0		011_3_11435	56147664	0
	011A_1_32745	55257313	1		004_3_10722	56147520	0	56147672	011A_0_25340	56147672	1
	011_1_11314	55257313	0	56147560	011A_0_25340	56147560	1		011A_1_32745	56147672	1
	011_2_11372	55257313	0		011A_1_32745	56147560	1		011_0_11257	56147672	0
	011_3_11435	55257313	0		011_0_11257	56147560	0		011_1_11314	56147672	0
55257321	011A_0_25340	55257321	1		011_1_11314	56147560	0		011_2_11372	56147672	0
	011A_1_32745	55257321	1		011_2_11372	56147560	0		011_3_11435	56147672	0
	011_1_11314	55257321	0		011_3_11435	56147560	0	56147703	011_0_11257	56147703	0
	011_2_11372	55257321	0	56147574	011A_0_25340	56147574	1		011_1_11314	56147703	0
	011_3_11435	55257321	0		011A_1_32745	56147574	1		011_2_11372	56147703	0
56137370	002_2_10522	56137370	0		011_0_11257	56147574	0		011_3_11435	56147703	0
	002_3_10539	56137370	0		011_1_11314	56147574	0	56147711	013_0_11706	56147711	0
	002_4_23307	56137370	0		011_2_11372	56147574	0		013_1_11755	56147711	0
	002_5_25058	56137370	1		011_3_11435	56147574	0		013_2_11805	56147711	0
	002_6_33590	56137370	1	56147646	011A_0_25340	56147646	1		013_3_11857	56147711	0



SPARE PARTS INSTANCE INDEX

Code	Parts Table	Pos.	Q.ty	Code	Parts Table	Pos.	Q.ty	Code	Parts Table	Pos.	Q.ty
56147845	003_0_10557	56147845	0	56148286	013_0_11706	56148286	0	56156261	004_4_25109	56156261	1
	003_1_10576	56147845	0		013_4_25436	56148286	1	56156276	003_4_27606	56156276	1
	003_2_10596	56147845	0		013_5_32888	56148286	1		003_5_33490	56156276	1
	003_3_25078	56147845	1	56148287	013_0_11706	56148287	0	56156281	003_4_27606	56156281	1
	003_4_27606	56147845	1		013_1_11755	56148287	0		003_5_33490	56156281	1
	003_5_33490	56147845	1		013_2_11805	56148287	0	56156284	003_5_33490	56156284	1
56147923	004_0_10617	56147923	0		013_3_11857	56148287	0	56156285	003_5_33490	56156285	1
	004_1_10650	56147923	0		013_4_25436	56148287	1	56156603	013_6_33211	56156603	1
	004_2_10685	56147923	0		013_5_32888	56148287	1		013_7_64065	56156603	1
	004_3_10722	56147923	0		013_6_33211	56148287	1	56156604	013_6_33211	56156604	1
	004_4_25109	56147923	1		013_7_64065	56148287	1		013_7_64065	56156604	1
56148031	001_0_10370	56148031	0	56148470	013_1_11755	56148470	0	56156940	011_4_25304	56156940	1
	001_1_10402	56148031	0		013_2_11805	56148470	0		011_5_32699	56156940	1
56148037	013_0_11706	56148037	0		013_3_11857	56148470	0		011_6_33168	56156940	1
	013_1_11755	56148037	0	56149590	002_2_10522	56149590	0		011_7_63924	56156940	1
	013_2_11805	56148037	0		002_3_10539	56149590	0	56156948	011_4_25304	56156948	1
	013_3_11857	56148037	0		002_4_23307	56149590	0		011_5_32699	56156948	1
	013_4_25436	56148037	1		002_5_25058	56149590	1		011_6_33168	56156948	1
	013_5_32888	56148037	1		002_6_33590	56149590	1		011_7_63924	56156948	1
	013_6_33211	56148037	1		002_7_63846	56149590	1	56157208	013_6_33211	56157208	1
	013_7_64065	56148037	1	56150361	013_0_11706	56150361	0		013_7_64065	56157208	1
56148184	009_0_11080	56148184	0		013_1_11755	56150361	0	56157239	011A_0_25340	56157239	1
	009_1_11107	56148184	0		013_2_11805	56150361	0		011A_1_32745	56157239	1
56148218	014_0_11909	56148218	0		013_3_11857	56150361	0		011_0_11257	56157239	0
	014_1_11927	56148218	0		013_4_25436	56150361	1		011_1_11314	56157239	0
	014_2_25485	56148218	1		013_5_32888	56150361	1		011_2_11372	56157239	0
56148285	013_0_11706	56148285	0		013_6_33211	56150361	1		011_3_11435	56157239	0
	013_1_11755	56148285	0		013_7_64065	56150361	1	56157267	011_0_11257	56157267	0
	013_2_11805	56148285	0	56152242	001_2_10428	56152242	0	56157271	011A_0_25340	56157271	1
	013_3_11857	56148285	0		001_3_10453	56152242	0		011A_1_32745	56157271	1
	013_4_25436	56148285	1		001_4_23329	56152242	0		011_0_11257	56157271	0
	013_5_32888	56148285	1	56152403	004_3_10722	56152403	0		011_1_11314	56157271	0
	013_6_33211	56148285	1		004_4_25109	56152403	1		011_2_11372	56157271	0
	013_7_64065	56148285	1	56156261	002_4_23307	56156261	1		011_3_11435	56157271	0



SPARE PARTS INSTANCE INDEX

Code	Parts Table	Pos.	Q.ty	Code	Parts Table	Pos.	Q.ty	Code	Parts Table	Pos.	Q.ty
56157303	011A_0_25340	56157303	1	56157539	001_5_24839	56157539	1	56356165	003_3_25078	56356165	1
	011A_1_32745	56157303	1		001_6_63810	56157539	1	56356251	003_0_10557	56356251	0
	011_0_11257	56157303	0	56157589	001_1_10402	56157589	0		003_1_10576	56356251	0
	011_1_11314	56157303	0	56157590	001_2_10428	56157590	0		003_2_10596	56356251	0
	011_2_11372	56157303	0		001_3_10453	56157590	0		003_3_25078	56356251	1
	011_3_11435	56157303	0		001_4_23329	56157590	0		003_4_27606	56356251	1
56157324	011A_0_25340	56157324	1		001_5_24839	56157590	1	56356328	006_0_10884	56356328	0
	011A_1_32745	56157324	1		001_6_63810	56157590	1		006_1_10921	56356328	0
	011_1_11314	56157324	0	56157603	001_5_24839	56157603	1		006_2_10958	56356328	0
	011_2_11372	56157324	0		001_6_63810	56157603	1		006_3_25213	56356328	1
	011_3_11435	56157324	0		002_2_10522	56157603	0	56356329	006_0_10884	56356329	0
56157332	013_1_11755	56157332	0		002_3_10539	56157603	0		006_1_10921	56356329	0
	013_2_11805	56157332	0		002_4_23307	56157603	0		006_2_10958	56356329	0
	013_3_11857	56157332	0		002_5_25058	56157603	1		006_3_25213	56356329	1
	013_4_25436	56157332	1		002_6_33590	56157603	1	56356330	006_0_10884	56356330	0
	013_5_32888	56157332	1		002_7_63846	56157603	1		006_1_10921	56356330	0
56157363	011A_1_32745	56157363	1	56157606	004_2_10685	56157606	0		006_2_10958	56356330	0
56157364	011A_1_32745	56157364	1		004_3_10722	56157606	0		006_3_25213	56356330	1
56157399	001_5_24839	56157399	1		004_4_25109	56157606	1	56356331	006_0_10884	56356331	0
	001_6_63810	56157399	1	56157607	004_2_10685	56157607	0		006_1_10921	56356331	0
56157411	011_4_25304	56157411	1		004_3_10722	56157607	0		006_2_10958	56356331	0
	011_5_32699	56157411	1		004_4_25109	56157607	1		006_3_25213	56356331	1
	011_6_33168	56157411	1	56157614	001_2_10428	56157614	0	56356348	006_2_10958	56356348	0
	011_7_63924	56157411	1		001_3_10453	56157614	0		006_3_25213	56356348	1
56157412	011_4_25304	56157412	1		001_4_23329	56157614	0	56356924	011_2_11372	56356924	0
	011_5_32699	56157412	1		001_5_24839	56157614	1		011_3_11435	56356924	0
	011_6_33168	56157412	1	56158943	006_3_25213	56158943	1		011_4_25304	56356924	1
	011_7_63924	56157412	1	56347484	003_3_25078	56347484	1		011_5_32699	56356924	1
56157481	001_6_63810	56157481	1		003_4_27606	56347484	1		011_6_33168	56356924	1
56157482	001_6_63810	56157482	1	56347700	011_0_11257	56347700	0		011_7_63924	56356924	1
56157485	001_6_63810	56157485	1		011_1_11314	56347700	0	56443871	009_0_11080	56443871	0
56157539	001_2_10428	56157539	0	56349649	014_2_25485	56349649	1		009_1_11107	56443871	0
	001_3_10453	56157539	0	56349782	003_3_25078	56349782	1	56448183	009_0_11080	56448183	0
	001_4_23329	56157539	0	56356165	003_2_10596	56356165	0		009_1_11107	56448183	0



SPARE PARTS INSTANCE INDEX

Code	Parts Table	Pos.	Q.ty	Code	Parts Table	Pos.	Q.ty	Code	Parts Table	Pos.	Q.ty
56448196	009_0_11080	56448196	0	58002538	013_2_11805	58002538	0	58043053	004_1_10650	58043053	0
	009_1_11107	56448196	0		013_3_11857	58002538	0		004_2_10685	58043053	0
56456347	006_0_10884	56456347	0		013_4_25436	58002538	1		004_3_10722	58043053	0
	006_1_10921	56456347	0		013_5_32888	58002538	1		004_4_25109	58043053	1
	006_2_10958	56456347	0		013_6_33211	58002538	1	58043086	006_0_10884	58043086	0
	006_3_25213	56456347	1		013_7_64065	58002538	1		006_1_10921	58043086	0
56456351	006_0_10884	56456351	0	58027230	011_2_11372	58027230	0		006_2_10958	58043086	0
	006_1_10921	56456351	0		011_3_11435	58027230	0		006_3_25213	58043086	1
	006_2_10958	56456351	0	58042111	001_2_10428	58042111	0	58043117	004_0_10617	58043117	0
	006_3_25213	56456351	1		001_3_10453	58042111	0		004_1_10650	58043117	0
56456476	006_0_10884	56456476	0		001_4_23329	58042111	0		004_2_10685	58043117	0
	006_1_10921	56456476	0		001_5_24839	58042111	1		004_3_10722	58043117	0
	006_2_10958	56456476	0		001_6_63810	58042111	1		004_4_25109	58043117	1
	006_3_25213	56456476	1	58042167	011_4_25304	58042167	1	58043176	011A_0_25340	58043176	1
56456479	006_3_25213	56456479	1		011_5_32699	58042167	1		011A_1_32745	58043176	1
56458942	006_3_25213	56458942	1		011_6_33168	58042167	1		011_0_11257	58043176	0
57148509	011_0_11257	57148509	0		011_7_63924	58042167	1		011_1_11314	58043176	0
	011_1_11314	57148509	0		013_0_11706	58042167	0		011_2_11372	58043176	0
	011_2_11372	57148509	0		013_1_11755	58042167	0		011_3_11435	58043176	0
	011_3_11435	57148509	0		013_2_11805	58042167	0	58043216	013_1_11755	58043216	0
58002429	011_0_11257	58002429	0		013_3_11857	58042167	0		013_2_11805	58043216	0
	011_1_11314	58002429	0		013_4_25436	58042167	1		013_3_11857	58043216	0
	011_2_11372	58002429	0		013_5_32888	58042167	1		013_6_33211	58043216	1
	011_3_11435	58002429	0		014_2_25485	58042167	1		013_7_64065	58043216	1
	013_0_11706	58002429	0	58042200	014_0_11909	58042200	0	58043219	013_0_11706	58043219	0
	013_1_11755	58002429	0		014_1_11927	58042200	0		013_1_11755	58043219	0
	013_2_11805	58002429	0		014_2_25485	58042200	1		013_2_11805	58043219	0
	013_3_11857	58002429	0	58042202	013_0_11706	58042202	0		013_3_11857	58043219	0
	013_4_25436	58002429	1		013_1_11755	58042202	0		013_4_25436	58043219	1
	013_5_32888	58002429	1		013_2_11805	58042202	0		013_5_32888	58043219	1
	013_6_33211	58002429	1		013_3_11857	58042202	0	58043250	015_0_11945	58043250	0
	013_7_64065	58002429	1		013_4_25436	58042202	1	58043253	013_4_25436	58043253	1
58002538	013_0_11706	58002538	0		013_5_32888	58042202	1		013_5_32888	58043253	1
	013_1_11755	58002538	0	58043053	004_0_10617	58043053	0	58043855	009_0_11080	58043855	0



SPARE PARTS INSTANCE INDEX

Code	Parts Table	Pos.	Q.ty	Code	Parts Table	Pos.	Q.ty	Code	Parts Table	Pos.	Q.ty
58043855	009_1_11107	58043855	0	58047606	011_2_11372	58047606	0	58048002	013_2_11805	58048002	0
58043874	009_0_11080	58043874	0		011_3_11435	58047606	0		013_3_11857	58048002	0
	009_1_11107	58043874	0	58047647	013_0_11706	58047647	0		013_4_25436	58048002	1
58043881	009_0_11080	58043881	0		013_1_11755	58047647	0		013_5_32888	58048002	1
	009_1_11107	58043881	0		013_2_11805	58047647	0	58048009	011_4_25304	58048009	1
58044804	015_0_11945	58044804	0		013_3_11857	58047647	0		011_5_32699	58048009	1
58045804	002_3_10539	58045804	0	58047649	013_6_33211	58047649	1		011_6_33168	58048009	1
	002_4_23307	58045804	0		013_7_64065	58047649	1		011_7_63924	58048009	1
	002_5_25058	58045804	1	58047671	011A_0_25340	58047671	1		013_0_11706	58048009	0
	002_6_33590	58045804	1		011A_1_32745	58047671	1		013_1_11755	58048009	0
	002_7_63846	58045804	1		011_0_11257	58047671	0		013_2_11805	58048009	0
58045805	002_5_25058	58045805	1		011_1_11314	58047671	0		013_3_11857	58048009	0
58045807	002_5_25058	58045807	1		011_2_11372	58047671	0	58048012	013_0_11706	58048012	0
	002_6_33590	58045807	1		011_3_11435	58047671	0		013_1_11755	58048012	0
	002_7_63846	58045807	1	58047712	011_4_25304	58047712	1		013_4_25436	58048012	1
58046901	016_0_12023	58046901	0		011_5_32699	58047712	1		013_5_32888	58048012	1
58046902	016_0_12023	58046902	0		011_6_33168	58047712	1		013_6_33211	58048012	1
58046903	016_0_12023	58046903	0		011_7_63924	58047712	1		013_7_64065	58048012	1
58046909	016_0_12023	58046909	0		013_0_11706	58047712	0	58048214	014_0_11909	58048214	0
58046910	016_0_12023	58046910	0		013_1_11755	58047712	0		014_1_11927	58048214	0
58046912	016_0_12023	58046912	0		013_2_11805	58047712	0		014_2_25485	58048214	1
	016_1_12046	58046912	0		013_3_11857	58047712	0	58048215	014_0_11909	58048215	0
	016_2_25498	58046912	1	58047729	016_2_25498	58047729	1		014_1_11927	58048215	0
	016_3_32939	58046912	1		016_3_32939	58047729	1		014_2_25485	58048215	1
58046913	016_0_12023	58046913	0	58048000	013_0_11706	58048000	0	58048330	015_0_11945	58048330	0
	016_1_12046	58046913	0		013_1_11755	58048000	0	58048355	013_6_33211	58048355	1
	016_2_25498	58046913	1		013_2_11805	58048000	0	58049501	013_0_11706	58049501	0
58047438	001_0_10370	58047438	0		013_3_11857	58048000	0		013_1_11755	58049501	0
	001_1_10402	58047438	0		013_4_25436	58048000	1		013_2_11805	58049501	0
58047568	013_0_11706	58047568	0		013_5_32888	58048000	1		013_3_11857	58049501	0
	013_1_11755	58047568	0		013_6_33211	58048000	1		013_4_25436	58049501	1
	013_2_11805	58047568	0		013_7_64065	58048000	1		013_5_32888	58049501	1
58047606	011_0_11257	58047606	0	58048002	013_0_11706	58048002	0		013_7_64065	58049501	1
	011_1_11314	58047606	0		013_1_11755	58048002	0	58049541	002_5_25058	58049541	1



SPARE PARTS INSTANCE INDEX

Code	Parts Table	Pos.	Q.ty	Code	Parts Table	Pos.	Q.ty	Code	Parts Table	Pos.	Q.ty
58049541	002_6_33590	58049541	1	58052028	017_0_25512	58052028	1	58056391	006_1_10921	58056391	0
	002_7_63846	58049541	1	58052029	016_0_12023	58052029	0		006_2_10958	58056391	0
58049663	013_6_33211	58049663	1		016_1_12046	58052029	0		006_3_25213	58056391	1
	013_7_64065	58049663	1		017_0_25512	58052029	1	58056593	013_3_11857	58056593	0
58049830	011_2_11372	58049830	0	58052035	016_0_12023	58052035	0		013_4_25436	58056593	1
	011_3_11435	58049830	0		016_1_12046	58052035	0		013_5_32888	58056593	1
58050345	013_0_11706	58050345	0		017_0_25512	58052035	1		013_6_33211	58056593	1
	013_1_11755	58050345	0	58052036	016_0_12023	58052036	0		013_7_64065	58056593	1
	013_2_11805	58050345	0		016_1_12046	58052036	0	58056595	013_6_33211	58056595	1
	013_6_33211	58050345	1		017_0_25512	58052036	1		013_7_64065	58056595	1
	013_7_64065	58050345	1	58052108	011_0_11257	58052108	0	58056918	011_4_25304	58056918	1
58051670	013_0_11706	58051670	0		011_1_11314	58052108	0		011_5_32699	58056918	1
	013_1_11755	58051670	0		011_2_11372	58052108	0		011_6_33168	58056918	1
	013_2_11805	58051670	0		011_3_11435	58052108	0		011_7_63924	58056918	1
	013_3_11857	58051670	0	58052152	017_0_25512	58052152	1	58056942	011_4_25304	58056942	1
	013_4_25436	58051670	1	58052288	015_3_64117	58052288	1		011_5_32699	58056942	1
	013_5_32888	58051670	1	58052305	001_0_10370	58052305	0		011_6_33168	58056942	1
58052013	016_0_12023	58052013	0		001_1_10402	58052305	0		011_7_63924	58056942	1
	016_1_12046	58052013	0	58052307	013_0_11706	58052307	0	58056991	001_5_24839	58056991	1
	017_0_25512	58052013	1	58052308	013_0_11706	58052308	0		001_6_63810	58056991	1
58052019	016_0_12023	58052019	0	58052326	015_1_11971	58052326	0		011_4_25304	58056991	1
	016_1_12046	58052019	0		015_2_11997	58052326	0		011_5_32699	58056991	1
	017_0_25512	58052019	1		015_3_64117	58052326	1		011_6_33168	58056991	1
58052025	016_0_12023	58052025	0	58052327	015_1_11971	58052327	0		011_7_63924	58056991	1
	016_1_12046	58052025	0		015_2_11997	58052327	0	58057205	013_6_33211	58057205	1
	017_0_25512	58052025	1		015_3_64117	58052327	1		013_7_64065	58057205	1
58052026	016_0_12023	58052026	0	58052328	015_1_11971	58052328	0	58057216	013_6_33211	58057216	1
	016_1_12046	58052026	0		015_2_11997	58052328	0		013_7_64065	58057216	1
	017_0_25512	58052026	1		015_3_64117	58052328	1	58057232	011A_0_25340	58057232	1
58052027	016_0_12023	58052027	0	58053049	013_4_25436	58053049	1		011A_1_32745	58057232	1
	016_1_12046	58052027	0		013_5_32888	58053049	1		011_0_11257	58057232	0
	017_0_25512	58052027	1	58056155	013_4_25436	58056155	1		011_1_11314	58057232	0
58052028	016_0_12023	58052028	0		013_5_32888	58056155	1		011_2_11372	58057232	0
	016_1_12046	58052028	0	58056391	006_0_10884	58056391	0		011_3_11435	58057232	0



SPARE PARTS INSTANCE INDEX

Code	Parts Table	Pos.	Q.ty	Code	Parts Table	Pos.	Q.ty	Code	Parts Table	Pos.	Q.ty
58057263	013_0_11706	58057263	0	58057385	001_5_24839	58057385	1	58057611	002_7_63846	58057611	1
	013_1_11755	58057263	0		001_6_63810	58057385	1	58057625	016_3_32939	58057625	1
	013_2_11805	58057263	0	58057386	002_2_10522	58057386	0	58057676	016_0_12023	58057676	0
	013_3_11857	58057263	0		002_3_10539	58057386	0		016_1_12046	58057676	0
	013_4_25436	58057263	1		002_4_23307	58057386	0		016_2_25498	58057676	1
	013_5_32888	58057263	1		002_5_25058	58057386	1		016_3_32939	58057676	1
	013_6_33211	58057263	1		002_6_33590	58057386	1	58057677	016_0_12023	58057677	0
	013_7_64065	58057263	1		002_7_63846	58057386	1		016_1_12046	58057677	0
58057287	013_1_11755	58057287	0	58057401	013_3_11857	58057401	0		016_2_25498	58057677	1
	013_2_11805	58057287	0	58057413	011_4_25304	58057413	1		016_3_32939	58057677	1
	013_3_11857	58057287	0		011_5_32699	58057413	1	58057678	016_0_12023	58057678	0
58057289	013_4_25436	58057289	1		011_6_33168	58057413	1		016_1_12046	58057678	0
	013_5_32888	58057289	1		011_7_63924	58057413	1		016_2_25498	58057678	1
58057336	013_4_25436	58057336	1	58057417	011_4_25304	58057417	1		016_3_32939	58057678	1
	013_5_32888	58057336	1		011_5_32699	58057417	1	58057688	016_0_12023	58057688	0
58057337	013_2_11805	58057337	0		011_6_33168	58057417	1		016_1_12046	58057688	0
	013_3_11857	58057337	0		011_7_63924	58057417	1		016_2_25498	58057688	1
58057343	013_2_11805	58057343	0	58057418	013_4_25436	58057418	1		016_3_32939	58057688	1
	013_3_11857	58057343	0		013_5_32888	58057418	1	58057704	011_0_11257	58057704	0
	013_4_25436	58057343	1		013_6_33211	58057418	1		011_1_11314	58057704	0
	013_5_32888	58057343	1		013_7_64065	58057418	1		011_2_11372	58057704	0
58057354	013_4_25436	58057354	1	58057419	011_7_63924	58057419	1		011_3_11435	58057704	0
	013_5_32888	58057354	1	58057422	013_7_64065	58057422	1		016_0_12023	58057704	0
	013_6_33211	58057354	1	58057610	002_2_10522	58057610	0		016_1_12046	58057704	0
	013_7_64065	58057354	1		002_3_10539	58057610	0		016_2_25498	58057704	1
58057355	013_6_33211	58057355	1		002_4_23307	58057610	0		016_3_32939	58057704	1
	013_7_64065	58057355	1		002_5_25058	58057610	1	58057724	016_0_12023	58057724	0
58057369	013_6_33211	58057369	1		002_6_33590	58057610	1		016_1_12046	58057724	0
58057384	002_2_10522	58057384	0		002_7_63846	58057610	1		016_2_25498	58057724	1
	002_3_10539	58057384	0	58057611	002_2_10522	58057611	0		016_3_32939	58057724	1
	002_4_23307	58057384	0		002_3_10539	58057611	0	58057746	016_3_32939	58057746	1
	002_5_25058	58057384	1		002_4_23307	58057611	0	58057748	016_3_32939	58057748	1
	002_6_33590	58057384	1		002_5_25058	58057611	1	58057767	016_1_12046	58057767	0
	002_7_63846	58057384	1		002_6_33590	58057611	1		016_2_25498	58057767	1



SPARE PARTS INSTANCE INDEX

Code	Parts Table	Pos.	Q.ty	Code	Parts Table	Pos.	Q.ty	Code	Parts Table	Pos.	Q.ty
58057767	016_3_32939	58057767	1	59015425	004_2_10685	59015425	0	59052238	001_2_10428	59052238	0
58057768	016_1_12046	58057768	0		004_3_10722	59015425	0		001_3_10453	59052238	0
	016_2_25498	58057768	1		004_4_25109	59015425	1		001_4_23329	59052238	0
	016_3_32939	58057768	1	59047417	001_0_10370	59047417	0	59052239	001_2_10428	59052239	0
58057770	016_1_12046	58057770	0		001_1_10402	59047417	0		001_3_10453	59052239	0
	016_2_25498	58057770	1	59047422	001_0_10370	59047422	0		001_4_23329	59052239	0
	016_3_32939	58057770	1		001_1_10402	59047422	0		001_5_24839	59052239	1
58057772	016_1_12046	58057772	0	59047441	001_0_10370	59047441	0		001_6_63810	59052239	1
	016_2_25498	58057772	1		001_1_10402	59047441	0	59052240	013_1_11755	59052240	0
	016_3_32939	58057772	1	59047445	001_0_10370	59047445	0		013_2_11805	59052240	0
58057773	016_3_32939	58057773	1		001_1_10402	59047445	0		013_3_11857	59052240	0
58057774	016_3_32939	58057774	1	59047666	011_0_11257	59047666	0	59052262	001_2_10428	59052262	0
58093089	016_3_32939	58093089	1		011_1_11314	59047666	0		001_3_10453	59052262	0
58135120	001_6_63810	58135120	1		011_2_11372	59047666	0		001_4_23329	59052262	1
58135225	002_7_63846	58135225	1		011_3_11435	59047666	0	59052322	001_2_10428	59052322	0
58147704	013_4_25436	58147704	1	59047709	013_0_11706	59047709	0		001_3_10453	59052322	0
	013_5_32888	58147704	1		013_1_11755	59047709	0		001_4_23329	59052322	0
	013_6_33211	58147704	1		013_2_11805	59047709	0		001_5_24839	59052322	1
	013_7_64065	58147704	1		013_3_11857	59047709	0		001_6_63810	59052322	1
58150313	013_0_11706	58150313	0	59047929	001_0_10370	59047929	0	59052346	011_2_11372	59052346	0
	013_1_11755	58150313	0	59048199	009_0_11080	59048199	0	59052347	011_3_11435	59052347	0
	013_2_11805	58150313	0		009_1_11107	59048199	0	59053222	001_4_23329	59053222	1
	013_3_11857	58150313	0	59048200	014_0_11909	59048200	0		001_5_24839	59053222	1
	013_4_25436	58150313	1		014_1_11927	59048200	0		001_6_63810	59053222	1
	013_5_32888	58150313	1		014_2_25485	59048200	1	59056258	002_2_10522	59056258	0
	013_6_33211	58150313	1	59048208	014_0_11909	59048208	0		002_3_10539	59056258	0
	013_7_64065	58150313	1		014_1_11927	59048208	0		002_4_23307	59056258	0
58156156	013_4_25436	58156156	1		014_2_25485	59048208	1		004_4_25109	59056258	1
	013_5_32888	58156156	1	59052105	011_0_11257	59052105	0	59056259	002_4_23307	59056259	1
	013_6_33211	58156156	1		011_1_11314	59052105	0		004_4_25109	59056259	1
	013_7_64065	58156156	1	59052110	011_2_11372	59052110	0	59056365	006_0_10884	59056365	0
58157405	002_7_63846	58157405	1		011_3_11435	59052110	0		006_1_10921	59056365	0
59015425	004_0_10617	59015425	0	59052220	013_0_11706	59052220	0		006_2_10958	59056365	0
	004_1_10650	59015425	0	59052231	001_0_10370	59052231	0		006_3_25213	59056365	1



SPARE PARTS INSTANCE INDEX

Code	Parts Table	Pos.	Q.ty	Code	Parts Table	Pos.	Q.ty	Code	Parts Table	Pos.	Q.ty
59056383	006_1_10921	59056383	0	59057317	011A_0_25340	59057317	1	59247924	003_4_27606	59247924	1
	006_2_10958	59056383	0		011A_1_32745	59057317	1		003_5_33490	59247924	1
	006_3_25213	59056383	1		011_1_11314	59057317	0	59247971	003_0_10557	59247971	0
59056385	006_0_10884	59056385	0		011_2_11372	59057317	0		003_1_10576	59247971	0
59056935	011_4_25304	59056935	1		011_3_11435	59057317	0		003_2_10596	59247971	0
	011_5_32699	59056935	1	59057477	001_5_24839	59057477	1		003_3_25078	59247971	1
59056970	011_0_11257	59056970	0		001_6_63810	59057477	1		003_4_27606	59247971	1
	011_1_11314	59056970	0	59057596	001_2_10428	59057596	0		003_5_33490	59247971	1
59056997	011_4_25304	59056997	1		001_3_10453	59057596	0	59256252	003_0_10557	59256252	0
	011_5_32699	59056997	1		001_4_23329	59057596	0		003_1_10576	59256252	0
59057000	011_6_33168	59057000	1		001_5_24839	59057596	1	59256253	003_3_25078	59256253	1
	011_7_63924	59057000	1	59057604	002_2_10522	59057604	0	59256255	003_5_33490	59256255	1
59057008	011A_1_32745	59057008	1		002_3_10539	59057604	0	59256265	003_2_10596	59256265	0
59057010	011_6_33168	59057010	1		002_4_23307	59057604	0	59256275	003_4_27606	59256275	1
	011_7_63924	59057010	1		002_5_25058	59057604	1		003_5_33490	59256275	1
59057011	011_6_33168	59057011	1		002_6_33590	59057604	1	59256279	003_4_27606	59256279	1
	011_7_63924	59057011	1		002_7_63846	59057604	1		003_5_33490	59256279	1
59057025	011_4_25304	59057025	1	59057608	002_2_10522	59057608	0	59256280	003_5_33490	59256280	1
	011_5_32699	59057025	1		002_3_10539	59057608	0	59257140	013_6_33211	59257140	1
59057027	011A_0_25340	59057027	1		002_4_23307	59057608	0	59257147	013_7_64065	59257147	1
59057033	011_4_25304	59057033	1		002_5_25058	59057608	1	59257157	013_5_32888	59257157	1
	011_5_32699	59057033	1		002_6_33590	59057608	1	59257158	013_5_32888	59257158	1
59057036	013_4_25436	59057036	1		002_7_63846	59057608	1	59257200	013_6_33211	59257200	1
59057048	011_5_32699	59057048	1	59057615	001_2_10428	59057615	0		013_7_64065	59257200	1
59057117	013_4_25436	59057117	1		001_3_10453	59057615	0	59257409	011_4_25304	59257409	1
59057210	013_6_33211	59057210	1		001_4_23329	59057615	0		011_5_32699	59257409	1
	013_7_64065	59057210	1		001_5_24839	59057615	1		011_6_33168	59257409	1
59057277	011_0_11257	59057277	0	59247884	003_0_10557	59247884	0		011_7_63924	59257409	1
59057300	011A_0_25340	59057300	1		003_1_10576	59247884	0	92480703	015_0_11945	92480703	0
	011A_1_32745	59057300	1		003_2_10596	59247884	0		015_1_11971	92480703	0
	011_0_11257	59057300	0		003_3_25078	59247884	1		015_2_11997	92480703	0
	011_1_11314	59057300	0		003_4_27606	59247884	1		015_3_64117	92480703	1
	011_2_11372	59057300	0		003_5_33490	59247884	1	92480718	015_0_11945	92480718	0
	011_3_11435	59057300	0	59247924	003_3_25078	59247924	1		015_1_11971	92480718	0



SPARE PARTS INSTANCE INDEX

Code	Parts Table	Pos.	Q.ty	Code	Parts Table	Pos.	Q.ty	Code	Parts Table	Pos.	Q.ty
92480718	015_2_11997	92480718	0	F0300016188	014_0_11909	F0300016	0	F0837534060	014_0_11909	F0837534	0
	015_3_64117	92480718	1		014_1_11927	F0300016	0		014_1_11927	F0837534	0
92480719	015_0_11945	92480719	0	F0300016189	014_0_11909	F0300016	0	F0837554000	011_0_11257	F0837554	0
	015_1_11971	92480719	0		014_1_11927	F0300016	0		011_1_11314	F0837554	0
	015_2_11997	92480719	0	F0300016199	011_0_11257	F0300016	0		011_2_11372	F0837554	0
	015_3_64117	92480719	1		011_1_11314	F0300016	0		011_3_11435	F0837554	0
92480720	015_0_11945	92480720	0		011_2_11372	F0300016	0	F0856348050	014_0_11909	F0856348	0
	015_1_11971	92480720	0		011_3_11435	F0300016	0		014_1_11927	F0856348	0
	015_2_11997	92480720	0	F0810505010	014_0_11909	F0810505	0	F0857276092	014_0_11909	F0857276	0
	015_3_64117	92480720	1		014_1_11927	F0810505	0		014_1_11927	F0857276	0
92480721	015_0_11945	92480721	0	F0814732000	011_0_11257	F0814732	0	F0858540000	014_0_11909	F0858540	0
	015_1_11971	92480721	0		011_1_11314	F0814732	0		014_1_11927	F0858540	0
	015_2_11997	92480721	0		011_2_11372	F0814732	0	F0862600000	014_0_11909	F0862600	0
	015_3_64117	92480721	1		011_3_11435	F0814732	0		014_1_11927	F0862600	0
92480757	015_0_11945	92480757	0	F0825500200	002_6_33590	F0825500	1	F0863086000	013_0_11706	F0863086	0
	015_1_11971	92480757	0		002_7_63846	F0825500	1		013_1_11755	F0863086	0
	015_2_11997	92480757	0	F0825500210	002_6_33590	F0825500	1		013_2_11805	F0863086	0
	015_3_64117	92480757	1		002_7_63846	F0825500	1		013_3_11857	F0863086	0
92480758	015_0_11945	92480758	0	F0825500220	002_6_33590	F0825500	1	F0864074050	011_0_11257	F0864074	0
	015_1_11971	92480758	0		002_7_63846	F0825500	1		011_1_11314	F0864074	0
	015_2_11997	92480758	0	F0826016000	011_0_11257	F0826016	0		011_2_11372	F0864074	0
	015_3_64117	92480758	1		011_1_11314	F0826016	0		011_3_11435	F0864074	0
92480836	015_0_11945	92480836	0		011_2_11372	F0826016	0				
	015_1_11971	92480836	0		011_3_11435	F0826016	0				
	015_2_11997	92480836	0	F0826038000	011_0_11257	F0826038	0				
	015_3_64117	92480836	1		011_1_11314	F0826038	0				
F0300002174	011_0_11257	F0300002	0		011_2_11372	F0826038	0				
	011_1_11314	F0300002	0		011_3_11435	F0826038	0				
	011_2_11372	F0300002	0	F0831148000	011_0_11257	F0831148	0				
	011_3_11435	F0300002	0		011_1_11314	F0831148	0				
F0300016152	011_0_11257	F0300016	0		011_2_11372	F0831148	0				
	011_1_11314	F0300016	0		011_3_11435	F0831148	0				
	011_2_11372	F0300016	0	F0831193010	011A_0_25340	F0831193	1				
	011_3_11435	F0300016	0		011A_1_32745	F0831193	1				